

User's Manual

EHP-200A

**ELECTRIC AND MAGNETIC
FIELD PROBE - ANALYZER**

From 9 kHz up to 30 MHz

EHP-200AC

**ELECTRIC AND MAGNETIC
FIELD PROBE - ANALYZER**

From 3 kHz up to 30 MHz

NEED HELP?



**SCAN OR CLICK HERE
TO CONTACT US**



Air-Met Scientific
www.airmet.com.au

SERIAL NUMBER OF THE INSTRUMENT

You can find the Serial Number on the bottom cover of the instrument.

The Serial Number is in the form: 000XY00000.

The first three digits and the two letters are the Serial Number prefix, the last five digits are the Serial Number suffix. The prefix is the same for identical instruments, it changes only when a configuration change is made to the instrument.

The suffix is different for each instrument

Document EHP200EN-20131-1.95 – Copyright © NARDA 2022

NOTE:

® Names and Logo are registered trademarks of Narda Safety Test Solutions GmbH – Trade names are trademarks of the owners.



If the instrument is used in any other way than as described in this User's Manual, it may become unsafe.

Before using this product, the related documentation must be read with great care and fully understood to familiarize with all the safety prescriptions.

To ensure the correct use and the maximum safety level, the User shall know all the instructions and recommendations contained in this document.




This product is a **Safety Class III** instrument according to IEC classification and has been designed to meet the requirements of EN61010-1 (Safety Requirements for Electrical Equipment for Measurement, Control and Laboratory Use).

In accordance with the IEC classification, the power supply of this product meets requirements **Safety Class II** and **Installation Category II** (having double insulation and able to carry out mono-phase power supply operations).

It complies with the requirements of **Pollution Class II** (usually only non-conductive pollution). However, occasionally it may become temporarily conductive due to condense on it.

The information contained in this document is subject to change without notice.

EXPLANATION OF ELECTRICAL AND SAFETY SYMBOLS :

 You now own a high-quality instrument that will give you many years of reliable service. Nevertheless, even this product will eventually become obsolete. When that time comes, please remember that electronic equipment must be disposed of in accordance with local regulations. This product conforms to the WEEE Directive of the European Union (2002/96/EC) and belongs to Category 9 (Monitoring and Control Instruments). You can return the instrument to us free of charge for proper environment friendly disposal. You can obtain further information from your local Narda Sales Partner or by visiting our website at www.narda-sts.it.



Warning, danger of electric shock



Earth



Read carefully the Operating Manual and its instructions, pay attention to the safety symbols.



Unit Earth Connection



Earth Protection



Equipotential

EXPLANATION OF SYMBOLS USED IN THIS DOCUMENT :



The DANGER sign draws attention to a serious risk to a person's safety, which, if not avoided, will result in death or serious injury. All the precautions must be fully understood and applied before proceeding.



The WARNING sign indicates a hazardous situation, which, if not avoided, could result in death or serious injury. All the precautions must be fully understood and applied before proceeding.



The CAUTION sign indicates a hazardous situation, which, if not avoided, could result in minor or moderate injury.



The NOTICE sign draws attention to a potential risk of damage to the apparatus or loss of data.



The NOTE sign draws attention to important information.

Contents

| | |
|--|-------------------|
| Safety requirements and instructions..... | Page VI |
| EC Declaration of Conformity | VII |
| | |
| 1 General information | Page |
| 1.1 Documentation..... | 1-1 |
| 1.2 Introduction | 1-1 |
| 1.3 Standard accessories..... | 1-2 |
| 1.4 Optional accessories | 1-2 |
| 1.5 EHP-200A Main specifications..... | 1-3 |
| 1.6 EHP-200A panel..... | 1-3 |
| 1.7 EHP-200AC Main specifications..... | 1-4 |
| 1.8 EHP-200AC panel..... | 1-4 |
| 1.9 Anisotropy..... | 1-5 |
| | |
| 2 Installation and Use | Page |
| 2.1 Introduction..... | 2-1 |
| 2.2 Preliminary Inspection..... | 2-1 |
| 2.3 Work environment..... | 2-1 |
| 2.4 To return for repair..... | 2-1 |
| 2.5 To clean the meter..... | 2-1 |
| 2.6 Installation of the EHP-200A/AC..... | 2-2 |
| 2.7 EHP-200A/AC on and Led status..... | 2-4 |
| 2.8 Power supply and battery charging..... | 2-5 |
| 2.9 Battery management..... | 2-5 |
| 2.10 Run EHP200-TS application..... | 2-6 |
| 2.11 Avoiding measurement errors..... | 2-6 |
| | |
| 3 EHP200-TS Software | Page |
| 3.1 Introduction..... | 3-1 |
| 3.2 Hardware requirements..... | 3-1 |
| 3.3 Installing EHP200-TS Software..... | 3-2 |
| | |
| 4 EHP200-TS software description | Page |
| 4.1 EHP200-TS Applications..... | 4-1 |
| 4.2 EHP200-TS controls and function..... | 4-2 |
| 4.2.1 Main menu..... | 4-2 |
| 4.2.2 Plot ranges colours..... | 4-3 |
| 4.3 Mode. section..... | 4-4 |
| 4.4 Span section..... | 4-5 |
| 4.5 Standard section..... | 4-7 |
| 4.6 Data section..... | 4-9 |
| 4.6.1 Z Wave..... | 4-13 |
| 4.6.2 Manual | 4-14 |
| 4.6.3 Waterfall..... | 4-15 |
| 4.6.3.1 Data recording..... | 4-19 |
| 4.7 Style section..... | 4-20 |
| 4.8 Additional functions provided by EHP200-TS | 4-21 |
| 4.9 ICNIRP | 4-23 |
| 4.10 IEEE..... | 4-26 |

| | |
|---|-------------|
| 5 Update Firmware | Page |
| 5.1 Update firmware..... | 5-1 |
| 5.2 To run the update software..... | 5-1 |
| 5.3 To transfer data | 5-1 |
| | |
| 6 Uninstalling software | Page |
| 6.1 Uninstalling EHP-TS Software | 6-1 |
| | |
| 7 Uninstalling USB-OC | Page |
| 7.1 Uninstalling driver for USB-OC..... | 7-1 |
| | |
| 8 Accessories | Page |
| 8.1 Introduction..... | 8-1 |
| 8.1.1 Preliminary inspection..... | 8-1 |
| 8.1.2 Work environment..... | 8-1 |
| 8.1.3 Return for repair..... | 8-1 |
| 8.1.4 Cleaning..... | 8-1 |
| 8.1.5 Power supply and battery chargers..... | 8-2 |
| 8.2 USB-OC Optical USB Converter..... | 8-3 |
| 8.2.1 Introduction..... | 8-3 |
| 8.2.2 Installation..... | 8-3 |
| 8.3 8053-OC Optical RS232 Converter..... | 8-4 |
| 8.3.1 Introduction..... | 8-4 |
| 8.3.2 Installation..... | 8-4 |
| 8.4 8053-OC-PS Power Supply..... | 8-5 |
| 8.4.1 Introduction..... | 8-5 |
| 8.4.2 Installation..... | 8-5 |
| 8.5 8053 DISPLAY..... | 8-6 |
| 8.5.1 Introduction..... | 8-6 |
| 8.5.2 Standard accessories..... | 8-6 |
| 8.5.3 Optional accessories..... | 8-6 |
| 8.5.4 Main specification..... | 8-7 |
| 8.5.5 Field probe..... | 8-8 |
| 8.5.6 Front panel..... | 8-9 |
| 8.5.7 Side panel..... | 8-9 |
| 8.5.8 Battery charger..... | 8-10 |
| 8.5.9 To substitute the mains connector..... | 8-10 |
| 8.5.10 To check the internal batteries..... | 8-10 |
| 8.6 TR-02A Tripod..... | 8-11 |
| 8.6.1 Introduction..... | 8-11 |
| 8.7 TT-01 Fiber glass Telescopic support..... | 8-13 |
| 8.7.1 Introduction..... | 8-13 |
| 8.8 Other accessories..... | 8-14 |
| | |
| 9 Software command protocol | Page |
| 9.1 Introduction..... | 9-1 |
| 9.2 Input select commands..... | 9-2 |
| 9.3 Setting commands..... | 9-3 |
| 9.4 Data request commands..... | 9-3 |
| 9.5 SWEEP Commands..... | 9-4 |

Figures

| Figure | | Page |
|--------|--|------|
| 1-1 | EHP-200A panel | 1-3 |
| 1-2 | EHP-200AC panel | 1-4 |
| 1-3 | 3D mesh measurements of magnetic probe..... | 1-5 |
| 1-4 | EHP-200A/EHP-200AC axes..... | 1-6 |
| 2-1 | EHP-200A/AC link with USB-OC..... | 2-2 |
| 2-2 | EHP-200A/AC link with 8053-OC..... | 2-2 |
| 2-3 | EHP-200A/AC Battery Discharging..... | 2-5 |
| 3-1 | EHP-TS Installation..... | 3-2 |
| 4-1 | EHP-200 EHP-TS Main Window..... | 4-2 |
| 4-2 | Plot ranges colours..... | 4-3 |
| 4-3 | Defining frequency band through the PC mouse... | 4-6 |
| 4-4 | Data section..... | 4-9 |
| 4-5 | Z Wave plot..... | 4-13 |
| 4-6 | Manual Mode | 4-14 |
| 4-7 | Waterfall - Graph 2D..... | 4-15 |
| 4-8 | Waterfall Main Window..... | 4-16 |
| 4-9 | Waterfall - Graph 3D..... | 4-17 |
| 4-10 | Both electric and magnetic fields displayed..... | 4-21 |
| 4-11 | Power density spectrum calculated and displayed | 4-21 |
| 4-12 | New wave impedance function | 4-22 |
| 4-13 | ICNIRP 1998 General Public limit selected..... | 4-24 |
| 4-14 | ICNIRP 2020 General Public limit selected..... | 4-25 |
| 5-1 | EHP200 Upgrading Utility Main Window..... | 5-1 |
| 6-1 | Uninstalling EHP-TS..... | 6-1 |
| 7-1 | Uninstalling USB-OC..... | 7-2 |
| 8-1 | USB-OC Adapter..... | 8-3 |
| 8-2 | 8053-OC Panels..... | 8-4 |
| 8-3 | 8053-OC-PS Connectors..... | 8-5 |
| 8-4 | 8053 DISPLAY Front Panel..... | 8-9 |
| 8-5 | 8053 DISPLAY Side Panel..... | 8-9 |
| 8-6 | TR-02A Tripod..... | 8-11 |
| 8-7 | TT-01 Fiber Glass Telescopic Support..... | 8-13 |

Tables

| Table | | Page |
|-------|---|------|
| 1-1 | Technical Specifications of the EHP-200A..... | 1-3 |
| 1-2 | Technical Specifications of the EHP-200AC..... | 1-4 |
| 2-1 | Led colours EHP-200A/AC..... | 2-4 |
| 8-1 | Technical Specifications of the USB-OC..... | 8-3 |
| 8-2 | Technical Specifications of the 8053-OC..... | 8-4 |
| 8-3 | Technical Specifications of the 8053-OC-PS..... | 8-5 |
| 8-4 | Technical Specifications of the 8053 DISPLAY..... | 8-7 |
| 8-5 | Series of electric and magnetic field probes..... | 8-8 |
| 8-6 | Technical Specifications of the TR-02A..... | 8-11 |
| 8-7 | Technical Specifications of the TT-01..... | 8-13 |

⚠ WARNING

SAFETY RECOMMENDATIONS AND INSTRUCTIONS

This product has been designed, produced and tested in Italy, and it left the factory in conditions fully complying with the current safety standards. To maintain it in safe conditions and ensure correct use, these general instructions must be fully understood and applied before the product is used.

- When the device must be connected permanently, first provide effective grounding;
- If the device must be connected to other equipment or accessories, make sure they are all safely grounded;
- In case of devices permanently connected to the power supply, and lacking any fuses or other devices of mains protection, the power line must be equipped with adequate protection commensurate to the consumption of all the devices connected to it;
- In case of connection of the device to the power mains, make sure before connection that the voltage selected on the voltage switch and the fuses are adequate for the voltage of the actual mains;
- Devices in Safety Class I, equipped with connection to the power mains by means of cord and plug, can only be plugged into a socket equipped with a ground wire;
- Any interruption or loosening of the ground wire or of a connecting power cable, inside or outside the device, will cause a potential risk for the safety of the personnel;
- Ground connections must not be interrupted intentionally;
- To prevent the possible danger of electrocution, do not remove any covers, panels or guards installed on the device, and refer only to NARDA Service Centers if maintenance should be necessary;
- To maintain adequate protection from fire hazards, replace fuses only with others of the same type and rating;
- Follow the safety regulations and any additional instructions in this manual to prevent accidents and damages.

Dichiarazione di Conformità *EC Declaration of Conformity*



In accordo alla Decisione 768/2008/EC, conforme alle direttive EMC 2014/30/UE, Bassa Tensione 2014/35/UE e RoHS 2011/65/UE, ed anche alle norme ISO/IEC 17050-1 e 17050-2.

In accordance with the Decision 768/2008/EC, compliant to the Directives EMC 2014/30/UE, Low Voltage 2014/35/UE and RoHS 2011/65/EU, also compliant to the ISO/IEC standard 17050-1 and 17050-2

Il costruttore
The manufacturer

narda Safety Test Solutions S.r.l. Socio Unico

Indirizzo
Address

Via Benessea, 29 / B

I-17035 Cisano sul Neva (SV) - Italy

sulla base delle seguenti norme europee armonizzate, applicate con esito positivo:
based on the following harmonized European Standards, successfully applied:

EMC - Emissioni:
EMC - Emission:

EN 61326-1 (2013)

EMC - Immunità:
EMC - Immunity:

EN 61326-1 (2013)

Sicurezza:
Safety:

CEI EN 61010-1 (2010)

dichiara, sotto la propria responsabilità, che il prodotto:
declares, under its sole responsibility, that the product:

Descrizione
Description

**SONDA ANALIZZATORE DI CAMPO ELETTRICO E MAGNETICO
ELECTRIC AND MAGNETIC FIELD PROBE - ANALYZER**

Modello
Model

EHP-200A

è conforme ai requisiti essenziali delle seguenti Direttive:
conforms with the essential requirements of the following Directives:

Bassa Tensione
Low Voltage

2014/35/EU

Compatibilità Elettromagnetica
EMC

2014/30/EU

RoHS
RoHS

2011/65/EU

Cisano sul Neva, 03 May 2017

Egon Stocca
General Manager

Dichiarazione di Conformità *EC Declaration of Conformity*

In accordo alla Decisione 768/2008/EC, conforme alle direttive EMC 2014/30/UE, Bassa Tensione 2014/35/UE e RoHS 2011/65/UE, ed anche alle norme ISO/IEC 17050-1 e 17050-2.

In accordance with the Decision 768/2008/EC, compliant to the Directives EMC 2014/30/UE, Low Voltage 2014/35/UE and RoHS 2011/65/EU, also compliant to the ISO/IEC standard 17050-1 and 17050-2

Il costruttore
The manufacturer **narda Safety Test Solutions S.r.l. Socio Unico**

Indirizzo
Address **Via Benessea, 29 / B**

I-17035 Cisano sul Neva (SV) - Italy

sulla base delle seguenti norme europee armonizzate, applicate con esito positivo:
based on the following harmonized European Standards, successfully applied:

EMC - Emissioni:
EMC - Emission: **EN 61326-1 (2013)**

EMC - Immunità:
EMC - Immunity: **EN 61326-1 (2013)**

Sicurezza:
Safety: **CEI EN 61010-1 (2010)**

dichiara, sotto la propria responsabilità, che il prodotto:
declares, under its sole responsibility, that the product:

Descrizione
Description **SONDA ANALIZZATORE DI CAMPO ELETTRICO E MAGNETICO
ELECTRIC AND MAGNETIC FIELD PROBE - ANALYZER**

Modello
Model **EHP-200AC**

è conforme ai requisiti essenziali delle seguenti Direttive:
conforms with the essential requirements of the following Directives:

Bassa Tensione
Low Voltage **2014/35/EU**

Compatibilità Elettromagnetica
EMC **2014/30/EU**

RoHS
RoHS **2011/65/EU**

Cisano sul Neva, 03 May 2017

Egon Stocca
General Manager



1 - General information

1.1 Documentation

Enclosed in this manual:

- service questionnaire to send back to NARDA
- check list of accessories enclosed in packaging.

1.2 Introduction



EHP-200A/AC E-H fields analyzer has been designed for accurate measurements of both electric (0.02 to 1000 V/m) and magnetic (3 mA/m to 300 A/m) fields in the frequency range 9 kHz to 30 MHz (**EHP-200A**) and both electric (0.02 to 1000 V/m) and magnetic (6 mA/m to 1000 A/m) fields in the frequency range 3 kHz to 30 MHz (**EHP-200AC**).

Both the field sensors and the electronic measuring circuitry are accommodated in a robust housing, only 92x92x109 mm in size.

Measurements are given separately for the 3-axis, or total value (peak and average), with exceptional flatness and linearity.

Results are expressed in V/m, A/m, microT, mG, mW/cm², W/m² and % of a selected limit.

The EHP-200A/AC features built-in spectrum analysis with minimum resolution of 1 kHz for detailed measurements of the E and H field intensity vs. frequency over a great dynamic range of 80 dB.

The power supply is provided by an internal Li-Ion battery for up to 12 hours of continuous operation, or from an external 10-15 V DC source by an AC adapter.

The EHP-200A/AC is controlled by a PC-based program, and measurements are transmitted in real time through a optical fiber link.

An auxiliary input allows for measuring the frequency spectrum of external signals from any other RF device.

Thanks to its very small size and to the optical fiber link, the EHP-200A/AC does not influence the electromagnetic fields under measure, thus ensuring more accurate and sensitive measurements.

Therefore the EHP-200A/AC is particularly suitable for nearby measurements of LW-AM-SW bands transmitters, metal detectors, and any other application requiring measurements of RF signals in the 9 kHz – 30 MHz range (**EHP-200A**) or in the 3 kHz – 30 MHz range (**EHP-200AC**), with great advantage wherever the conventional antennas are inadequate due to their physical dimensions, and cable influence must be prevented.

EHP-200A/AC is housed in a small cubic case and the bottom panel includes an optical fiber connector, thread insert, battery charger connector, ON/OFF button and Status LED.

The three magnetic sensors are magnetic loops positioned orthogonal each other and the electric sensor includes three orthogonal parallel plates capacitors installed on the opposite side of the magnetic ones.

1.3 Standard accessories Standard accessories included with EHP-200A/AC:

- 8053-SC Soft carrying case;
- AC/DC Converter with plug adapters;
- FO-8053/10 Cable, fiber optic 10m
- FO-10USB Cable, fiber optic 10m ;
- USB-OC Optical-USB converter ;
- Plastic rod support, 50cm;
- Mini tripod, bench top;
- EHP200-TS Software Media;
- Operating Manual;
- Certificate of calibration;
- Return for Repair Form.

1.4 Optional accessories The following accessories can be ordered separately:

- 8053-OC Optical RS232 converter;
- 8053-OC-PS Power Supply
- FO-8053/20 Cable, fiber optic 20 m
- FO-8053/40 Cable, fiber optic 40 m
- FO-8053/80 Cable, fiber optic 80 m
- TR-02A wooden tripod 1-2m with soft carrying bag
- TT-01 telescopic mast (120-420 cm) with carrying bag
- 8053-Display display unit
- 8053-CA car adapter
- 8053-CC rigid case
- EHP-50G



Updates of the software and firmware of the EHP-200A/AC can be downloaded from the Web site <http://www.narda-sts.it> or requested directly from NARDA Sales Centers.

1.5 EHP-200A Main specifications

The following conditions apply to all specifications:

- Operating ambient temperature must be between -10°C and 50° C.

| Table 1-1 Technical specifications of the EHP-200A Electric and Magnetic Field Analyzer | | | | |
|---|---|---|---|--------------------------------------|
| | Electric Field | Magnetic Field Mode A | Magnetic Field Mode B | AUX Input |
| Frequency range | 9 kHz ÷ 30 MHz | 9 kHz ÷ 3 MHz | 300 kHz ÷ 30 MHz | 9 kHz ÷ 30 MHz |
| Measurement range @10kHz RBW with preamplifier ON | 0.1 ÷ 1000 V/m 0.02 ÷ 200 V/m | 30 mA/m ÷ 300 A/m 6 mA/m ÷ 60 A/m | 3 mA/m ÷ 30 A/m 0.6 mA/m ÷ 6 A/m | -80 ÷ 0 dBm -94 ÷ -14 dBm |
| Dynamic range | > 80 dB | | | |
| Measurement range | > 94 dB | | | |
| Resolution | 0.01 V/m | 1 mA/m | 0.1 mA/m | 0.01 dB |
| Sensitivity @10kHz RBW (*) with preamplifier ON | 0.1 V/m 0.02 V/m | 30 mA/m 6 mA/m | 3 mA/m 0.6 mA/m | -80 dBm -94 dBm |
| Flatness | 0.5 dB 9 kHz ÷ 30 MHz @ 20 V/m | 0.8 dB 100 kHz ÷ 3 MHz @ 166 mA/m | 0.8 dB 300 kHz ÷ 30 MHz @ 53 mA/m | 0.4 dB 9 kHz ÷ 30 MHz @ -20dBm |
| Anisotropy @1MHz | 0.8 dB | | | --- |
| Reference frequency | < 25 ppm | | | |
| Linearity @1MHz | 0.5 dB from FS to -60 dBFS | | | |
| SPAN | 0 to FULL SPAN | | | |
| RBW | 1 kHz – 3 kHz – 10 kHz – 30 kHz – 100 kHz – 300 kHz | | | |
| Rejection to E fields | --- | > 20 dB | | --- |
| Rejection to H fields | > 20 dB | --- | | --- |
| Calibration | internal E ² PROM | | | |
| Temperature error | 0.02 dB/°C | | | |
| Dimensions | 92 x 92 x 109 mm | | | |
| Weight | 550 g | | | |
| Environmental protection | IP42 | | | |
| Preamplifier | selectable ON/OFF, 14dB | | | |
| Units | V/m, A/m, uT, mW/cm ² , W/m ² | | | |
| Internal battery | 3.7 V – 5.55 Ah Li-Ion, rechargeable | | | |
| Operation | > 12 hours | | | |
| Recharging time | < 8 hours | | | |
| External supply | 10 ÷ 15 VDC, I = approx. 560 mA | | | |
| Optical fiber connection | up to 10 m (USB-OC) up to 80 m (8053-OC) | | | |
| Firmware updating | through the optical link | | | |
| Self test | automatic at power on | | | |
| Operating temperature | -10 ÷ +50°C | | | |
| Storage temperature | -20 ÷ +70°C | | | |

Specifications are subject to change without notice

Specifications valid for probes produced or recalibrated since 10/2021

(*) The maximum sensitivity is achieved with the filter to 10 kHz

1.6 EHP-200A Panel

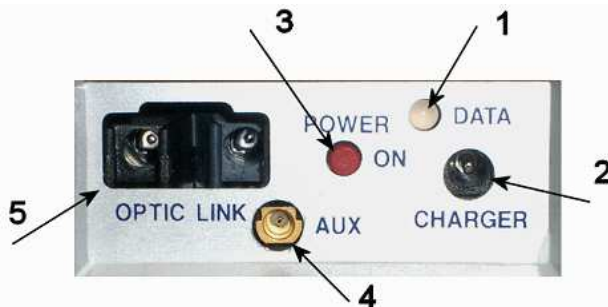


Fig. 1-1 EHP-200A Panel

Key:

1. Led
2. Battery charger connector
3. ON/OFF button
4. AUX input connector MMCX male type
5. Fiber optic connector

1.7 EHP-200AC Main specifications

The following conditions apply to all specifications:

- Operating ambient temperature must be between -10°C and 50° C.

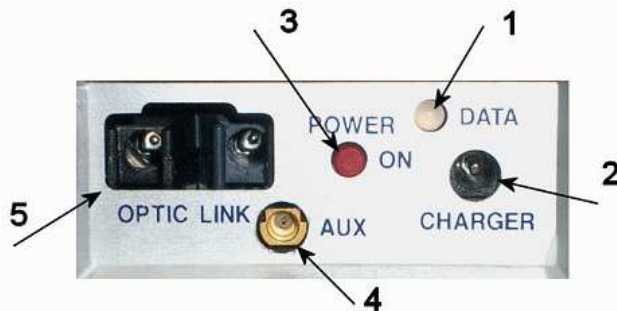
| Table 1-2 Technical specifications of the EHP-200AC Electric and Magnetic Field Analyzer | | | | |
|--|---|--------------------------------------|---|--------------------------------------|
| | Electric Field | Magnetic Field Mode A | Magnetic Field Mode B | AUX Input |
| Frequency range | 3 kHz ÷ 30 MHz | 3 kHz ÷ 300 kHz | 30 kHz ÷ 30 MHz | 3 kHz ÷ 30 MHz |
| Measurement range | | | | |
| @10kHz RBW | 0.1 ÷ 1000 V/m | 0.1 A/m ÷ 1 kA/m | 30 mA/m ÷ 300 A/m | -80 ÷ 0 dBm |
| with preamplifier ON | 0.02 ÷ 200 V/m | 20 mA/m ÷ 200 A/m | 6 mA/m ÷ 60 A/m | -94 ÷ -14 dBm |
| Dynamic range | > 80 dB | | | |
| Measurement range | > 94 dB | | | |
| Resolution | 0.01 V/m | 1 mA/m | 0.1 mA/m | 0.01 dB |
| Sensitivity @10kHz RBW (*) | 0.1 V/m | 0.1 A/m | 30 mA/m | -80 dBm |
| with preamplifier ON | 0.02 V/m | 20 mA/m | 6 mA/m | -94 dBm |
| Flatness | 0.5 dB 9 kHz ÷ 30 MHz @ 20 V/m | 0.8 dB 5 kHz ÷ 300 kHz @ 1 A/m | 0.8 dB 30 kHz ÷ 30 MHz @ 166 mA/m | 0.4 dB 3 kHz ÷ 30 MHz @ -20dBm |
| Anisotropy @ 300 kHz | 0.8 dB | | | --- |
| Reference frequency | < 25 ppm | | | |
| Linearity @ 300 kHz | 0.5 dB from FS to -60 dBFS | | | |
| SPAN | 0 to FULL SPAN | | | |
| RBW | 1 kHz – 3 kHz – 10 kHz – 30 kHz – 100 kHz – 300 kHz | | | |
| Rejection to E fields | --- | > 20 dB | | --- |
| Rejection to H fields | > 20 dB | --- | | --- |
| Calibration | internal E ² PROM | | | |
| Temperature error | 0.02 dB/°C | | | |
| Dimensions | 92 x 92 x 109 mm | | | |
| Weight | 550 g | | | |
| Environmental protection | IP42 | | | |
| Preamplifier | selectable ON/OFF, 14dB | | | |
| Units | V/m, A/m, uT, mW/cm ² , W/m ² | | | |
| Internal battery | 3.7 V – 5.55 Ah Li-Ion, rechargeable | | | |
| Operation | > 12 hours | | | |
| Recharging time | < 8 hours | | | |
| External supply | 10 ÷ 15 VDC, I = approx. 560 mA | | | |
| Optical fiber connection | up to 10 m (USB-OC) up to 80 m (8053-OC) | | | |
| Firmware updating | through the optical link | | | |
| Self test | automatic at power on | | | |
| Operating temperature | -10 ÷ +50°C | | | |
| Storage temperature | -20 ÷ +70°C | | | |

Specifications are subject to change without notice

Specifications valid for probes produced or recalibrated since 10/2021

(*) The maximum sensitivity achieved with the filter to 10 kHz

1.8 EHP-200AC Panel



Key:

1. Led
2. Battery charger connector
3. ON/OFF button
4. AUX input connector MMCX male type
5. Fiber optic connector

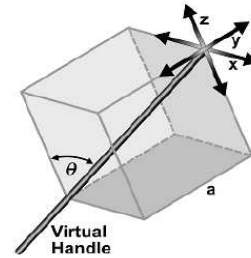
Fig. 1-2 EHP-200AC Panel

1.9 Anisotropy

1) The IEEE 1309 [3] defined the anisotropy (A) as the maximum deviation from the geometric mean of the maximum response and minimum response when the probe is rotated around the ortho-axis (e.g. "virtual handle") as shown in the example in figure below.

$$A = 20 \cdot \log_{10} \left(\frac{S_{\max}}{\sqrt{S_{\max} \cdot S_{\min}}} \right) \text{ dB} \quad \text{equation (1)}$$

where S is the measured amplitude in field strength units.



$$\theta = \sin^{-1} \left(\frac{\sqrt{2} a}{\sqrt{3} a} \right) = 54.7^\circ$$

2) The IEC 61786 [2] "Measurement of low-frequency magnetic and electric fields with regards to exposure of human beings - special requirements for instruments and guidance for measurements" does not define the anisotropy and suggests, for three-axis probes, the calibration of each axis when each element is aligned with the incident field.

The calibration should also be checked for a specific orientation where approximately there is the same indication for each one of the three axis (XYZ measurement).

Following this suggestion some laboratories find the minimum and the maximum values of the X,Y,Z and XYZ measure and calculate the anisotropy using equation (1).

3) We calculated the anisotropy with equation (1) but with 3D mesh measurements to cover 4π steradians, that is to say in a much more severe condition than the orthotropic one.

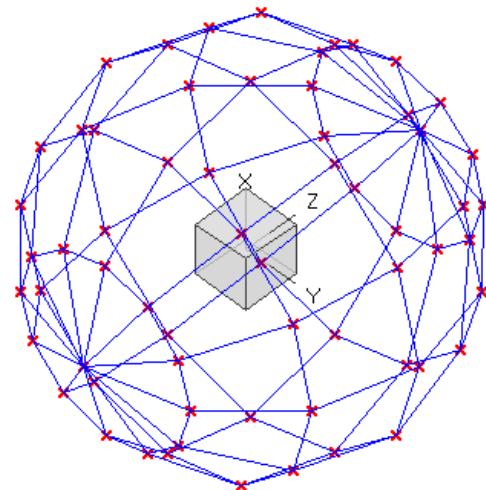
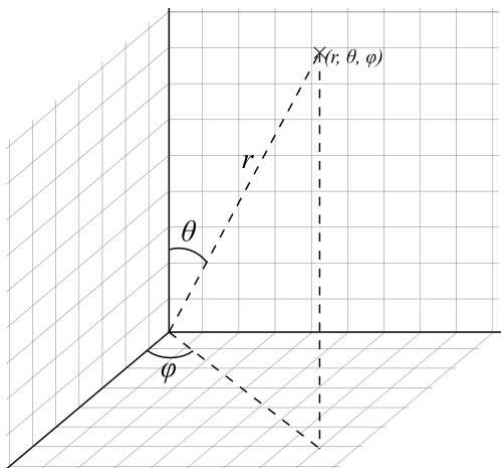


Fig. 1-3 3D mesh measurements of magnetic probe

Each x marker in the Fig.1-3 indicates the coordinates surface of the spherical coordinates (r, θ, φ) .

The anisotropy is evaluated with 30 degrees steps for θ and φ , and r shows the calibration factor at each position.

The typical value of anisotropy is 10% (0.8 dB).

The anisotropy calculated in this way is worse respect to the other cases above described, and it is more representative of the reality.

A good evaluation of the anisotropy of a field probe should be carried out in a place where all of the following conditions are satisfied:

- Far Field
- Plane wave
- Uniform field

Since the calibration systems are not infinite, these conditions can be approximated but never reached, and so the evaluation of anisotropy for our probes shows results worse than the reality. So, the real typical anisotropy response is better than what specified.

EHP-200A/AC is housed in a small cubic case and the bottom panel includes an optical fiber connector, threaded insert, battery charger connector, ON/OFF button and Status LED.

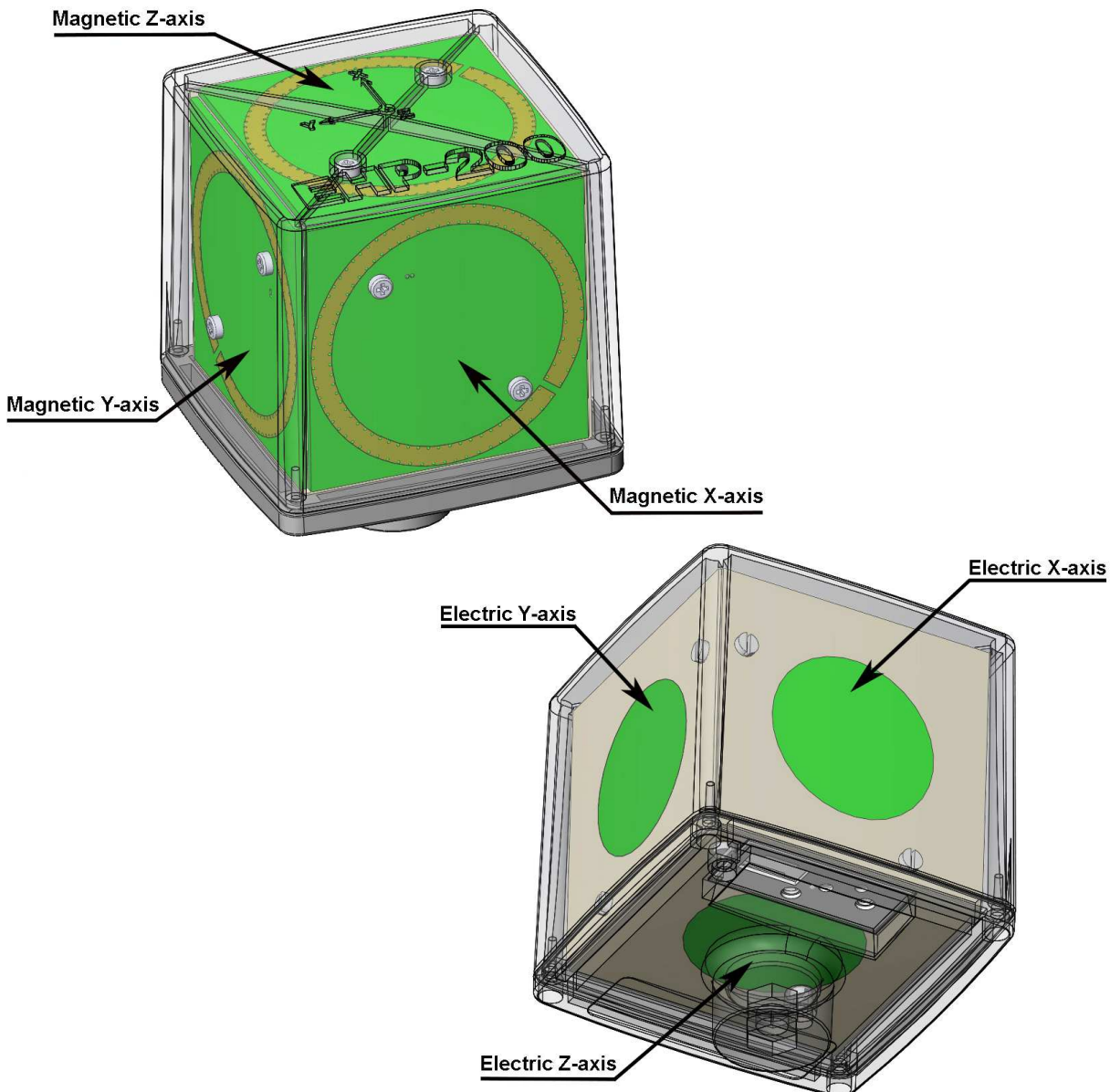
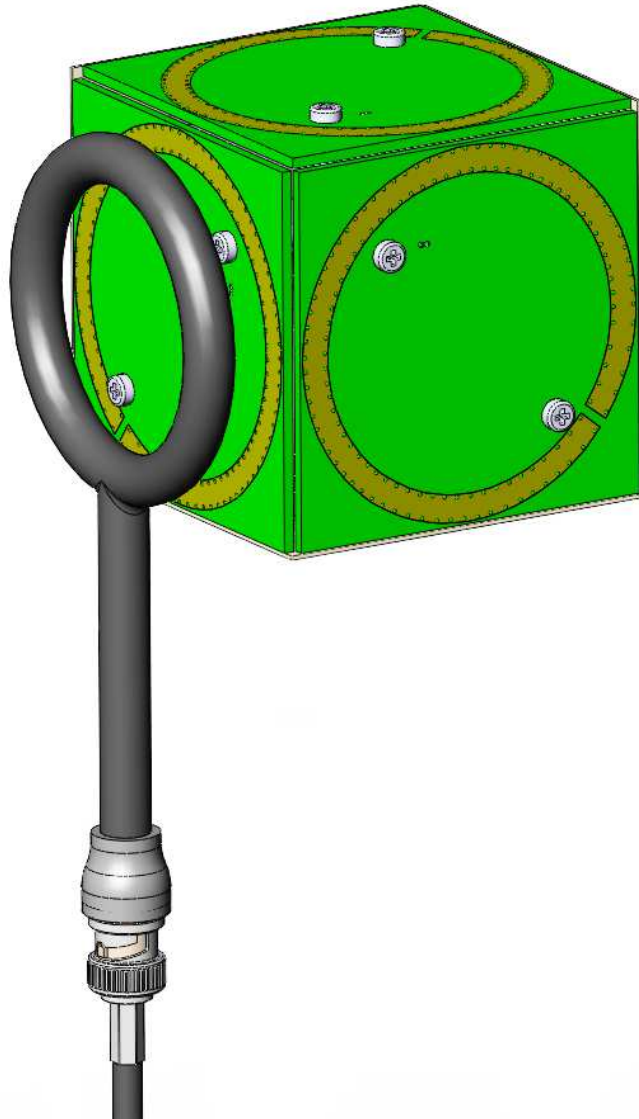


Fig. 1-4 EHP-200A/EHP-200AC axes

The sensitive elements are located approximately 8 mm below the external surface

As depicted above, the three magnetic sensor are magnetic loops positioned orthogonal each other and the electric sensor includes three orthogonal parallel plates capacitors installed on the opposite side of the magnetic ones.

The geometric structure of the Narda probes, with sensors placed on the peripheral faces of the cube, shows the same behavior as one with the sensors accumulated in the center, when measuring far fields. Moreover, this provides the opportunity to evaluate also very nearby fields, albeit with all the limitations that this entails, knowing exactly where the single sensor is, and allowing to minimize the contribution of the others.



This page has been left blank intentionally

2 – Installation and Use

2.1 Introduction

This section provides the information required for installing and using the EHP-200A/AC Analyzer.

Information is included regarding initial inspection, power requirements, interconnections, work environment, assembly, cleaning, storage and shipment.

2.2 Preliminary inspection

Inspect the packaging for any damage.

NOTICE

If the packaging or anti-shock material have been damaged, check that the contents are complete and that the meter has not suffered electric or mechanical damage.

Check that all the Accessories are there against the checklist found with the apparatus.

Inform the carrier and NARDA of any damage that has occurred.

2.3 Work environment

The work environment of the Accessories, must come within the following conditions:

- Temperature From -10°C to +50°C
- Humidity < 90% relative

The meter must be stored in a clean and dry environment, free from acid dusts and humidity.

The storage environment must come within the range of the following conditions:

- Temperature From -20°C to + 70°C
- Humidity < 95% relative

2.4 To return for repair

When the meter needs to be returned to NARDA for repair, please complete the questionnaire appended to this User's Manual, filling in all the data that will be useful for the service you have requested.

For reducing the period of time required for the repairs, it is necessary to be as specific as possible in describing the problem. If the problem only occurs in certain circumstances, please describe in detail how it happens.

If possible it is better to reuse the original packaging; making sure that the apparatus is wrapped in thick paper or plastic.

Otherwise, use strong packaging by using a sufficient quantity of shock absorbent material around all sides of the meter to ensure that it is compact and does not move around inside the package.

In particular, take every precaution to protect the front panels.

Finish the package by sealing it up tightly.

Apply a FRAGILE label to the package to encourage greater care in its handling.



Nowadays there are restrictions on the shipment of hazardous materials, eg. some types of lithium batteries.

Please, check the proper, safe, shipping mode, with the help of your courier, in the case the product is equipped with batteries.

2.5 To clean the meter

Use a dry, clean and non-abrasive cloth for cleaning the meter.

NOTICE

Do not use solvents, acids, turpentine, acetone or other similar products for cleaning the meter in order to avoid damaging it.

2.6 Installation of the EHP-200A/AC

Turn off the EHP-200A/AC, connect the supplied fiber optic to the **OPTIC LINK** connector taking care that the spigot matches the housing. Connect the other end of the fiber optic to the provided USB-OC (taking care that the grip recess points towards the center of the device) or **OPTIC LINK** connector of the optional 8053-OC. Connect the converter to a PC port.

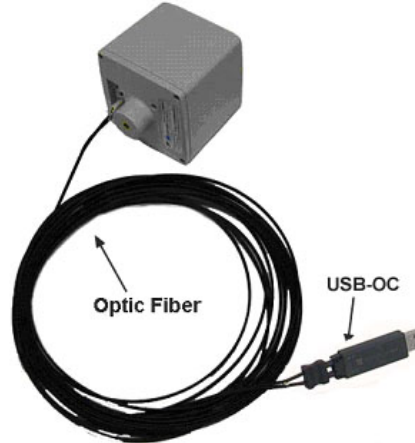


Fig. 2-1 EHP-200A/AC link with USB-OC

The USB-OC standard accessory connected to the EHP-200A/AC allows a 10m maximum fiber length

Instead if you connect the probe to the RS232 port, you must use the optional accessories 8053-OC.



Fig. 2-2 EHP-200A/AC link with 8053-OC

The 8053-OC optional accessory connected to the EHP-200A/AC allows a 80m maximum fiber length

NOTICE

Do not pull the fiber optic by holding onto the cable but use the connector so that the head does not get damaged. Avoid dirt and other particles getting into the transducers of the fiber optic.

With 8053-OC the program automatically establishes the connection on the first RS232 port that is not in use at that time, in the following order: COM1, COM2, COM3, etc.



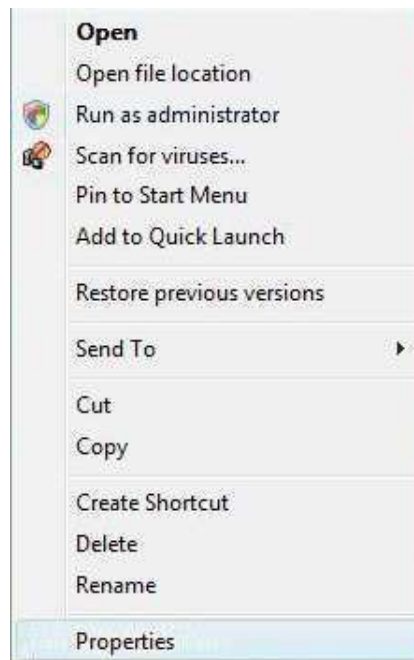
The energy available on the DB9 connector of some PC model could be not sufficient to guarantee a good link with 80 meter fiber.



The energy available on the DB9 connector of some PC model could be not sufficient to guarantee a link with 8053-OC. In this case, is necessary use 8053-OC-PS between the converter and PC (for more information see chapter 8 Accessories).

Whenever a port is tied up by a device which is not active or turned off at that time, the program recognises it as free and will therefore attempt to connect EHP-200A/AC to that port. In this case, it is necessary to “force” the next serial port by the following procedure:

- Right click on the program icon and select “properties”.



- Add the command COMM=N **preceded** by a **space** (in capital letters) at the end of the Destination field **where** N indicates the serial port to be used; for example, if the EHP-200A/AC is connected to port 2, add the command COMM=2.

The assigned COM port nr. must be between 1 and 9.



- In some operating system the Destination field is enclosed in double quotation marks (""); in this case, the command COMM=N, **preceded** by a **space** must be outside as in the example below;



- Then confirm by selecting Apply
- After switching the analyzer ON, run the control software.

2.7 EHP-200A/AC on and Led status

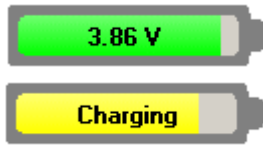
Turn on EHP-200A/AC by pushing the Red POWER button for one second.

After switching on the analyzer, the ORANGE led lights up for about 1/2 second as an auto-check, after that a red light starts blinking.

When switched on, the three-color ON DATA LED will provide the following information:

| Blinking speed | Colour of the LED | Meaning |
|-------------------------------|--------------------------|---|
| Changes depending on the SPAN | Green | Communication with PC in progress and correct |
| Medium | Red | PC disconnected or error in communication |
| FIX | Green | Recharging battery |
| Off | Off | Battery recharging completed |

2.8 Power supply and battery recharging



2.9 Battery management

EHP-200A/AC has an internal rechargeable Li-Ion battery that can be recharged with the battery charger supplied with it (it is the same model of the 8053 DISPLAY battery charger).

Ensure that the batteries are fully charged before using the Analyzer for longest battery operation time.

The battery status is reported by the EHP200-TS software and when charging is in progress the operator is warned in the battery sub-window.

ALWAYS connect the battery charger to the power supply **BEFORE** connecting it to the EHP-200A/AC.

The battery charger has an internal protective circuit that will limit the output of current if there is any load when connecting to the mains.

Battery charger:

output: DC, 10 - 15 V, ~ 500 mA



Connector:

In order to safeguard the features of the batteries, it is crucial to have a complete recharge before storing them for periods longer than 4 months. Therefore, it is warmly suggested recharging the batteries at least every 4 months even though the device has not been used.

The minimum voltage level for operation is about 3.25V. The batteries must be recharged for lower voltages. Below such voltage the analyzer will turn OFF automatically.

The time required for recharging the batteries is about 4-5 hours. When charging is in progress the led is green and once the recharge is complete the led turns OFF.

If the battery charger is plugged into the EHP-200A/AC while the software is running, the analyzer will stop the measurements.

EHP-200A/AC features an efficient control of the Li-Ion internal battery. The picture below shows the typical discharging curve:

Battery Discharging
(E-Field - Full Span - RBW 100KHz@25°C)

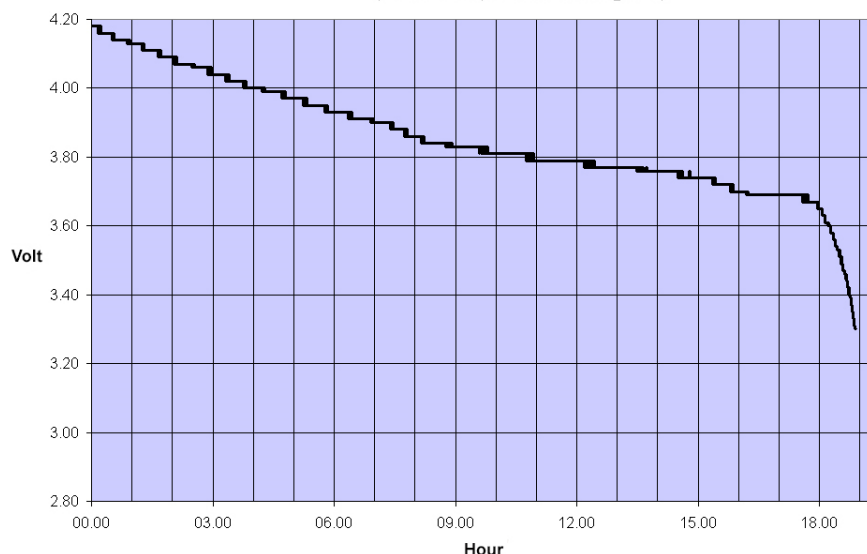


Fig. 2-3 EHP-200A/AC Battery Discharging

2.10 Run EHP200-TS application

Install the EHP200-TS software (see chapter 3) and the program automatically installs the driver for USB optical converter.

Run the EHP200-TS software (see chapter 4) and the EHP-200A/AC led turns on blinking **Green** light that means the correct communication.



If the attempt to communicate is not successful or if the fiber optic is not connected to the PC, the EHP-200A/AC will automatically switch off after about 30 minutes to preserve the battery charge.



EHP-200A/AC must be ON before running EHP200-TS control software. EHP-200A/AC may not be correctly recognized if switched ON when the control software is already running.



Pressing the POWER down button for more than 4 seconds forces the hardware of the apparatus to shut down. Then, it is necessary to wait several seconds before switching it on again.

2.11 Avoiding measurement errors

To avoid disturbing the measurements in progress, the user or other people or mobile vehicles should stay at least 5 meters away from the EHP-200A/AC Analyzers. We also recommend that the probe be set up far from metal objects or masses.

To perform correct measurements, the tripod TR-02A to hold EHP-200A/AC is recommended. Using an unsuitable support could influence the measurements thus giving incorrect results.



We recommend always using the supplied isolated extension rod together with the TR-02A optional tripod to positioning the EHP-200A/AC at the height stated by the reference standards for the measurement in progress.

Use the same configuration to ensure the measurements taken can be repeated.

The intensity of the measured field mainly depends on its voltage and the geometry of the system under analysis, as well as on the distance between the conductors and the measurement points. In proximity of the cables the field value reading may be very high and will vary according to the location of the probe.

From the definition of the potential difference between two points:

$$V_{21} = - \int_{r_1}^{r_2} \vec{E} dr$$



It is evident that, keeping the potential difference constant as the distance between the two points under examination decreases, the intensity of the field necessarily increases.

E.g.: the electric field intensity between two armatures of a parallel-plate capacitor situated at a distance of 0.1 m and having a potential difference of 100 V is equal to:

$$E = \frac{100V}{0.1m} = 1KV/m$$

It should be noted that a voltage of 100 V, in these conditions, generates a field of 1000 V/m. It is, therefore, possible, in the vicinity of 220 V conductors, that there may be a field which is much higher than 220 V/m.

3 – EHP200-TS software installation

3.1 Introduction

EHP200-TS is a useful software tool developed for remote PC control, through fiber optic link, of EHP-200A/AC Electromagnetic field analyzer.

By means of the recently introduced USB-OC optical to USB converter, EHP-200A/AC can be connected to a PC USB port

Using the former optical/RS232 adapter, the selected COM port should be assigned to the application software (see chapter 5, EHP200-TS applications).

EHP200-TS software requires that at least one of the mentioned analyzers is connected to PC in order to run.

The EHP200-TS installation program automatically installs the driver for USB optical converter.

3.2 Hardware requirements

Minimum requirements:

- Processor: Pentium or equivalent
- 256 MB RAM
- At least 64 MB of free space on hard disk
- 1 free USB or RS232 port
- Windows Operating system™ XP/Vista/Win7/Win8/Win8.1/Win10



The User might have the need of administrator privileges to install the software in Windows Vista, Win7, Win8, Win8.1 and Win10; for further information see the next paragraph.



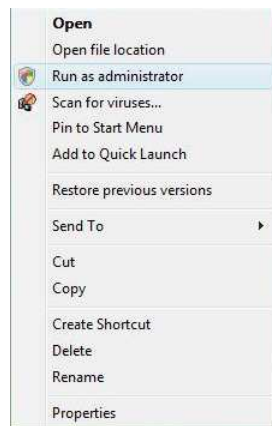
The new releases can be downloaded directly from the narda website <http://www.narda-sts.it>

3.3 Installing EHP200-TS Software

Before connecting the EM field analyzer to PC the EHP200-TS software installation should be performed:
Browse the Software Media and run the file “EHP-200 Setup.exe”.



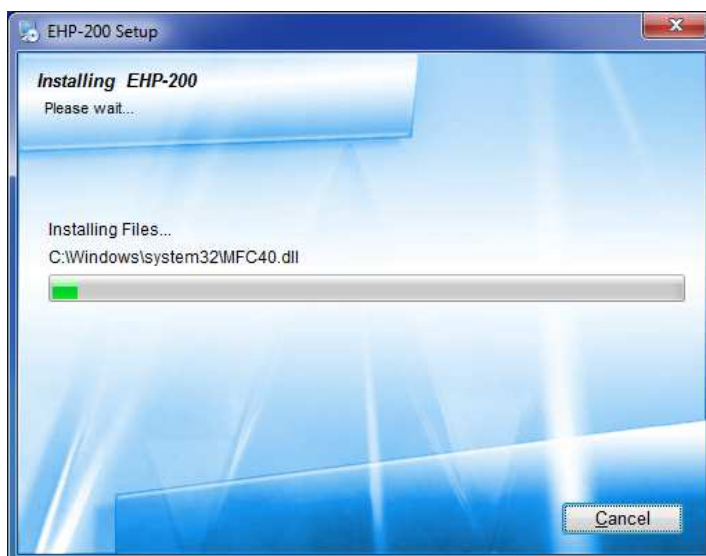
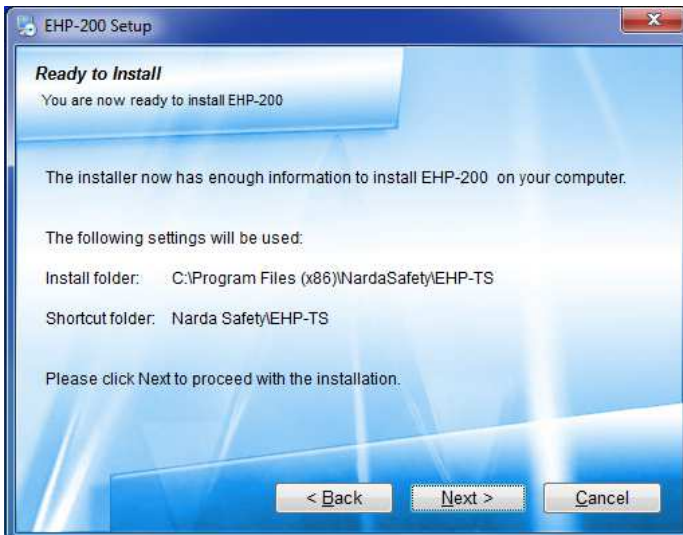
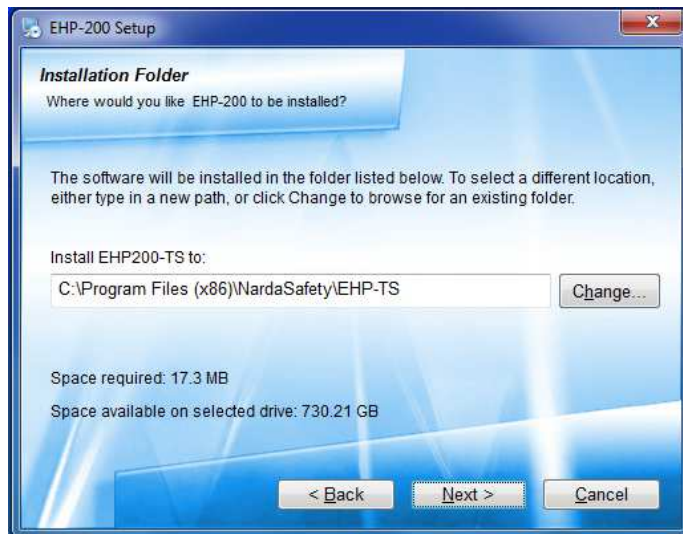
The User must have administrator privileges to install the EHP200-TS software in Windows Vista, Win7, Win8, Win8.1 and Win10; right click on the program .exe file and click on “Run as administrator” to temporarily run the program or application as an administrator until close it (Win7, Win8, Win8.1 and Win10 also allows to mark an application so that it always runs with administrator rights).

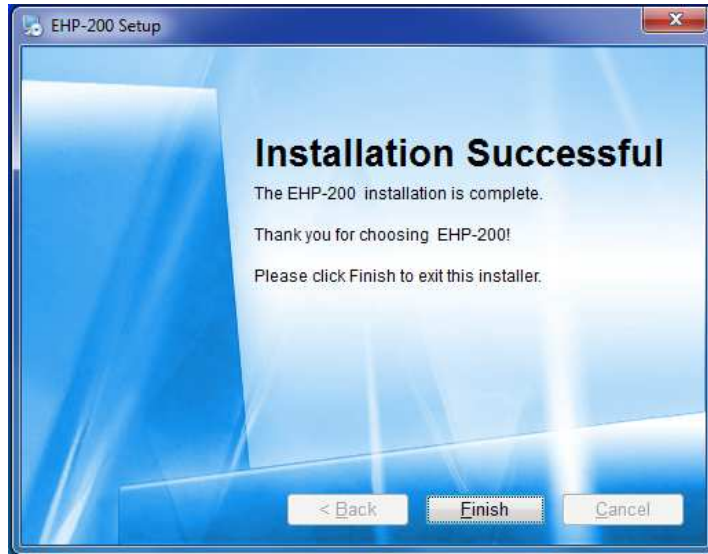


Follow set-up program instructions



Fig.3-1 EHP-TS installation






When asked for, reboot your system to complete installation.



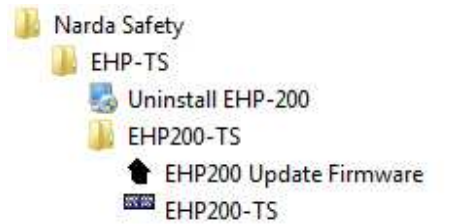
EHP200-TS software is now installed in your PC, you can remove it, if needed, simply running the "Uninstall EHP-200" application. (see chapter 6)

4 – EHP200-TS software description

4.1 EHP200-TS Applications

EHP-TS software includes different applications to be used with EHP family analyzers. Shortcuts are shown, selecting “all programs” from the windows XP “start” button or, using Windows Vista, Win7, Win8, Win8.1, Win10 by clicking **Windows** () and **Programs**:

The **EHP-200-TS** section includes two applications:



EHP-200 Update Firmware: this is a tool to update EHP-200A/AC firmware

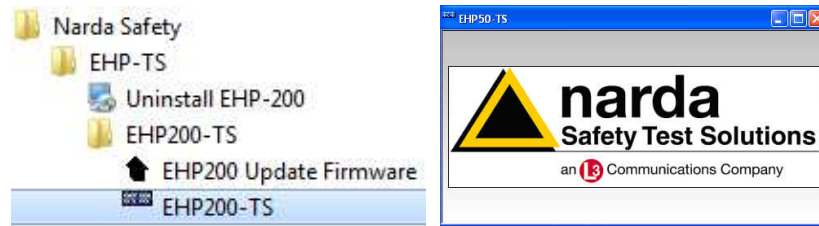
EHP200-TS: this program is used to perform measurements when an EHP-200A/AC analyzer is connected to PC

4.2 EHP200-TS controls and function

This chapter describes controls and function provided by EHP200-TS application:

4.2.1 Main menu

Switch the analyzer ON and run EHP200-TS application.



After the welcome screenshot appears for few seconds the program main window will be shown:

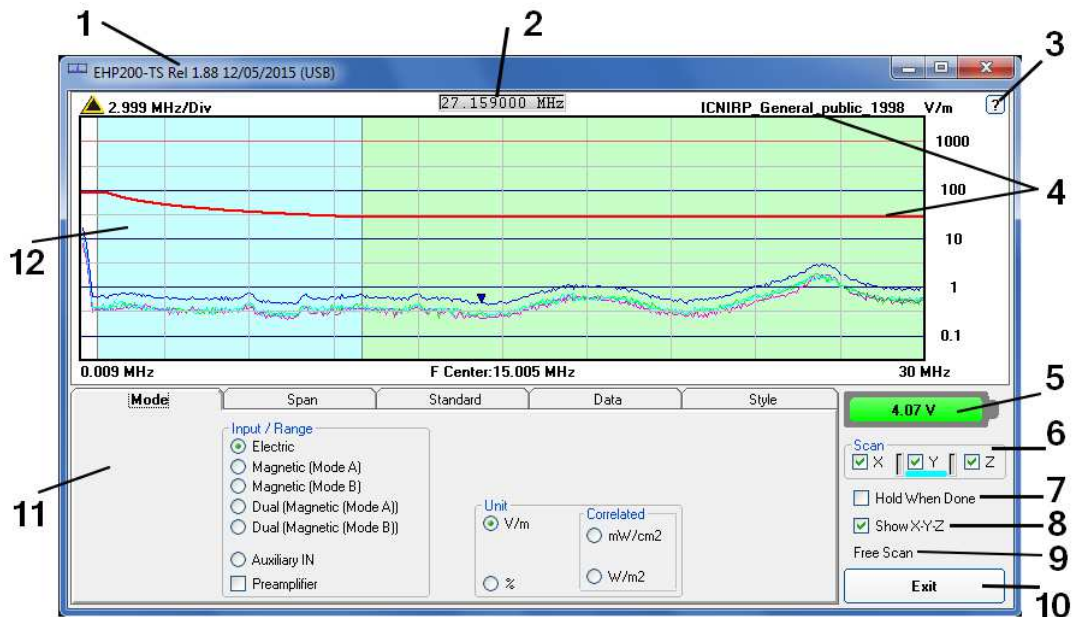


Fig.4-1 EHP200-TS Main Window

Description:

- 1 - EHP200-TS software release (communication port)
- 2 - Shows frequency while scanning
- 3 - Click “?” to display EHP-200A/AC analyzer information (Serial Number, Firmware release and Date of calibration etc.)
- 4 - Name and trace of selected Limit
- 5 - EHP-200A/AC analyzer battery status
- 6 - **Scan** activation for each axis (default setting: all axis activated)
- 7 - **Hold When Done:** stops scan to allow data analysis as soon as all axis have been measured
- 8 - **Show X-Y-Z:** to display, or not, the traces of single axis.
- 9 - Acquisition mode selected (see **Mode** section)
- 10 - **Exit** button to terminate application
- 11 - Control panel
- 12 - Display for spectrum analysis



The fiber optic of the EHP-200A/AC Analyzer can be disconnected and reconnected while in use. In this case, communication will be restarted automatically.

Commands are grouped in the control panel in 5 different sections:

Mode: to set different operating modes

Span: to set sweep parameter and Resolution Bandwidth

Standard: to create and save limit traces, to activate a specific limit

Data: to display measurement results and save data

Style: to change colours and buttons aspect

Each section can be activated with a mouse click.

4.2.2 Plot ranges colours

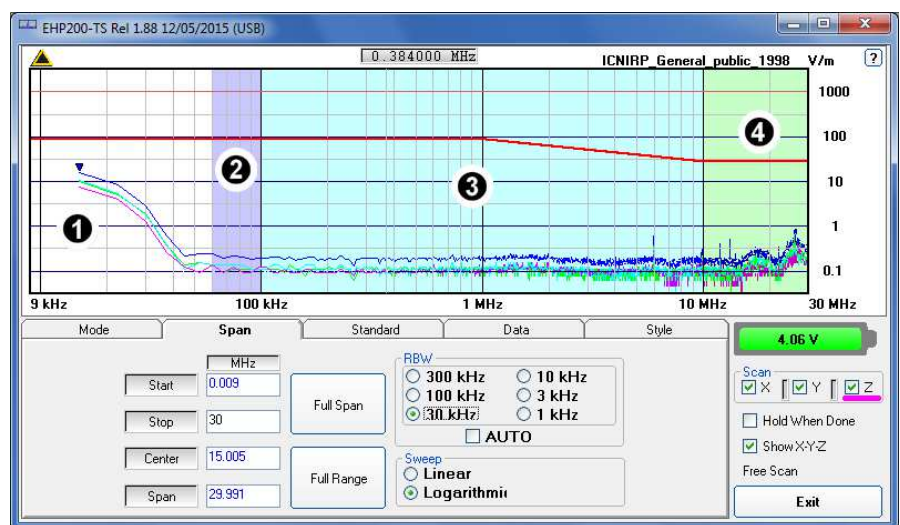


Fig.4-2 Plot ranges colours

As it is visible in the picture above, when a three axial measurement is selected, together with an active limit, the plot area is divided into up to 4 zones, of different colours.

The first (#1, white in the example) is the range affected by the DC offset and so it is not taken into account for the measurement result.

The other three areas become coloured when the measurement is completed and ready.

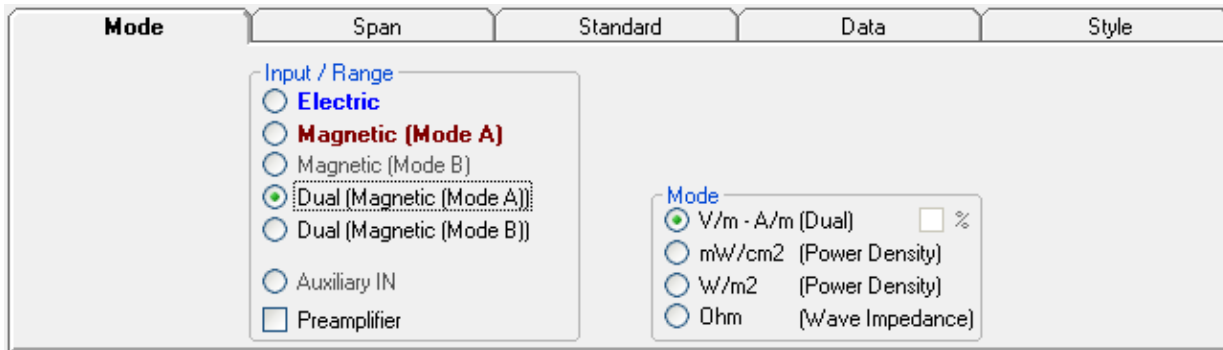
So at least three sweeps are needed to light up the coloured zones.

In the example, one of the ICNIRP limits is active.

The second zone (#2, violet in the example) refers to the linear effects range, the third zone (#3, cyan in the example) refers to the linear and quadratic effects range and the fourth zone (#4, green in the example) refers to the quadratic effects range.

4.3 Mode section

Mode section allows setting different acquisition modes, as well as defining Electric and Magnetic field, and preferred unit.



Input/Range: to select electric field, magnetic field in two different ranges, auxiliary input (50 Ohm input connector) and dual field mode in two different ranges.



Move the mouse cursor over “Magnetic” to display frequency range and level range of “Mode A” and “Mode B”.

Preamplifier: for best sensitivity when activated (vertical range changes accordingly).

Unit: to select unit according to the Input setting. Unless a **Dual** mode has been selected, Power density units are correlated ones assuming measurement to be performed in far field condition.



Power density units in Dual mode are calculated from both electric and magnetic field measurements (no correlated units included in the calculation) and therefore valid in both far field and near field condition.



The unit “%” can be selected only if a Limit has been activated. Each spectrum line will then represent the field strength expressed as percent of the selected limit.

Ω (Wave impedance) button: the selected input must be Dual (Magnetic mode A or B). When selected, the calculated wave impedance will be shown on the graph, instead of the field level.

It represents the 3 axis total E and H fields strength at each frequency.

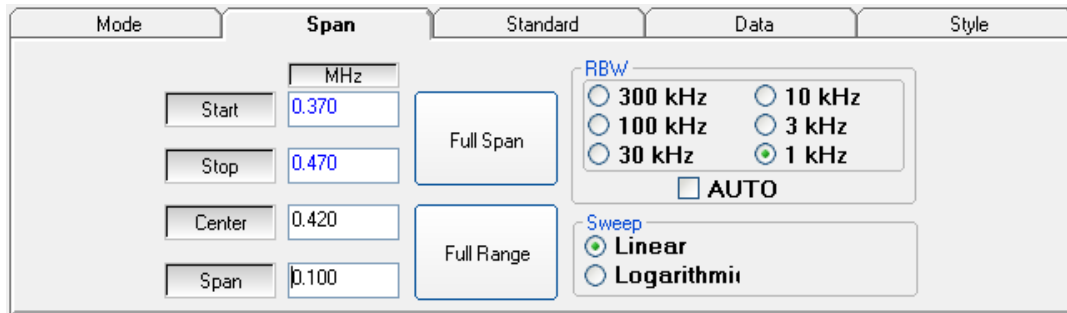
The wave impedance is the ratio between Electric and Magnetic field at each frequency. It is used for evaluations in near field condition.



To prevent measurement errors the wave impedance is obtained by the ratio $\frac{|E|}{|H|}$ at frequencies where both the fields are at least 10 dB above the noise floor of the instrument.

Back to any other unit button: to close the wave impedance display and switching back to the levels graph.

4.4 Span section



EHP-200A/AC does not include an FFT analyzer but a powerful receiver in the 9kHz – 30MHz frequency range (**EHP-200A**) or in the 3kHz – 30MHz frequency range (**EHP-200AC**). The span section includes the following controls:

Start, Stop, Center, Span: to easily set, as in any spectrum analyzer, the frequency sweep parameters.

Full Span button: to quickly set the frequency sweep parameters from 0 Hz to 30MHz.

Even if in this condition the graphical representation includes frequencies below the minimum operating range, it shows round values on each division of the vertical grid.

Full Range button: to quickly set the frequency sweep parameters from 9kHz to 30MHz (EHP-200A full frequency range) or from 3kHz to 30MHz (EHP-200AC full frequency range).

RBW: six different settings for the Resolution Bandwidth filter. This setting affects the sweep time (the higher RBW, the faster sweep) and frequency resolution (Lower RBW shows more details in the frequency axis).

When the RBW is set to **Coupled** the filter width is set automatically depending on the sweep setting

Depending on the **Sweep – Start** setting, the RBW filter should be set as narrow as enough to avoid the spectrum analyzer 0 Hz signal to be included in the displayed spectrum when an integration over the frequency range has to be performed.

RBW Auto is a useful function to select the RBW filter automatically, depending on the frequency span.

Linear Sweep or Logarithmic Sweep: this is used to select the linear or logarithmic frequency scale.

Logarithmic scale is used to empathize and clearly display low frequencies even though high ones are included in the graph. High frequencies are therefore compressed to the high side of displayed range.



Right click and drag on the graph window to define graphically the Zoom frequency range.

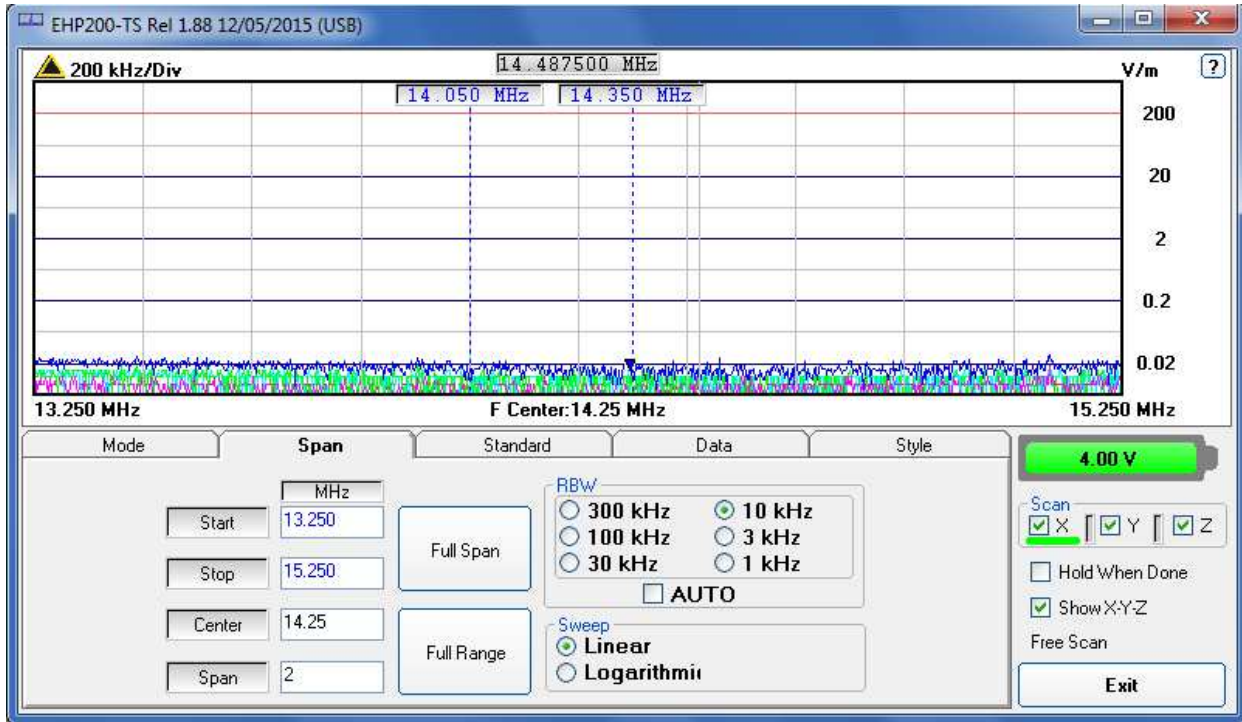
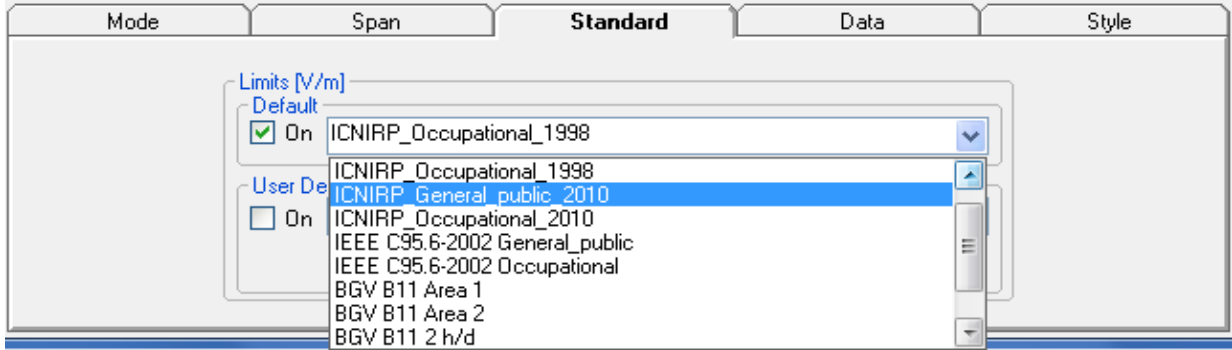


Fig.4-3 Defining frequency band through the PC mouse

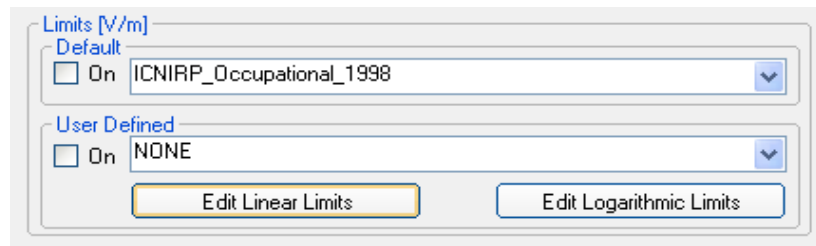
4.5 Standard section

Standard section allows the user to select standard ICNIRP, IEEE, BGV and EU limits, already included by the software installation, as well as user's limits which can be created through the "Make Limit" function provided by this section.

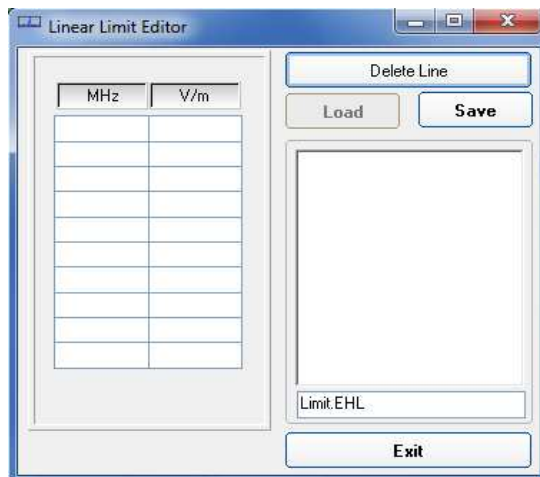


Default: The default limit section can be used to load a default standard limit saved into the memory at the factory. Default limit list shows limits which are compatible to the actual setting only. If Electric field was selected in the Mode section, electric field limits only are displayed by the limit list. No default limit is shown in case mG or correlated unit was selected.

User Defined: This limit section allows to select and activate a specific limit among the ones created and saved by the user. They can be Linear or Non Linear (governed by a mathematic formula).



The **Edit Linear Limits** button opens a window to edit linear limits and create new ones.

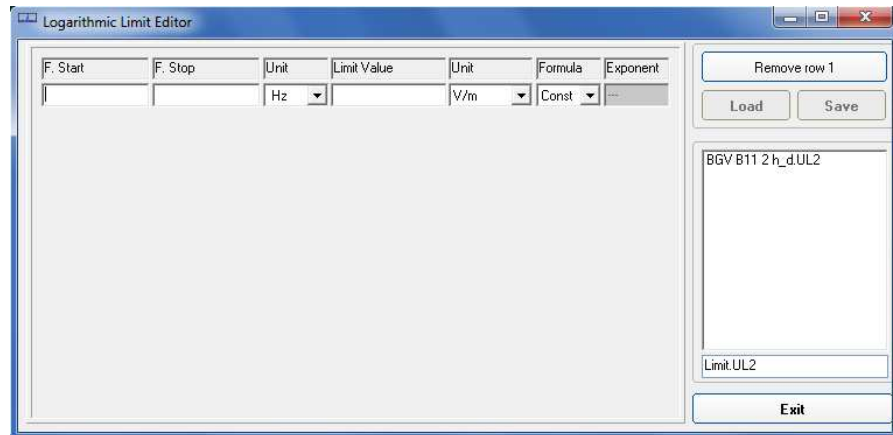


Type frequency and field strength for each point of the required limit and click save to save it under the program directory. The limit file will be created as a linear interpolation between specified points.



When the ICNIRP or IEEE limit is selected, the software automatically calculates the corresponding total integration of the measured signals, and compares the result with the threshold set by the standard, considering whether it is or is not exceeded.

The **Edit Logarithmic Limits** button opens a window to edit those limits that are related to log frequency axis, and create new ones:



Click **Load** to edit a previously saved limit.

Type in the Start and Stop frequencies in the appropriate boxes, and choose the right measurement Unit.

Introduce the strength Value and choose its Unit.

Then choose the formula from the list and type the exponent value.

Click save to save it under the program directory. The limit file will be created as a calculation of the mathematic expression.

4.6 Data section

Even if EHP-200A/AC takes measurement over the entire selected span, shown results are related to the displayed spectrum only, allowing thus detailed evaluation of user defineable frequency range through the zoom function.

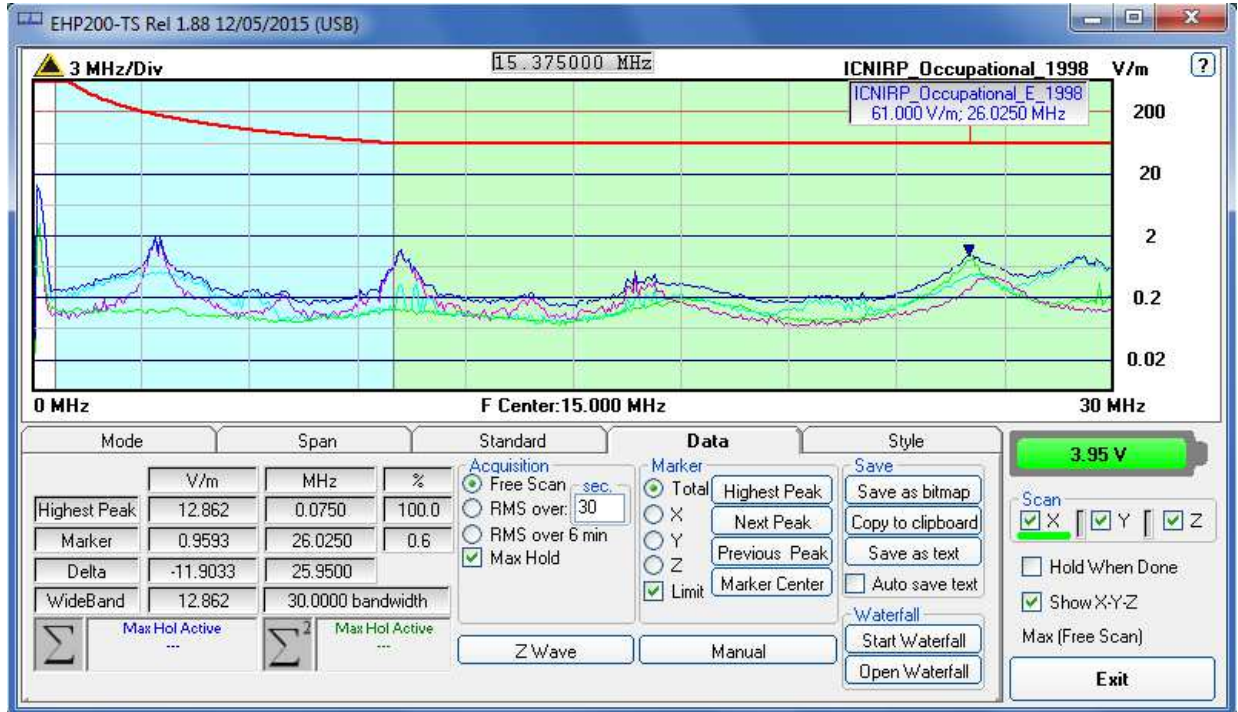


Fig.4-4 Data section

The white band on the left side of the graph highlights signals below the minimum start frequency (1.2 % of Span) which are affected by residual DC peak. Calculation of Wideband result does not include any spectral line within the white band.

Measurement result: the following values are showed in a table form:

Highest Peak: Maximum value within the displayed spectrum.

Shown parameters:

Highest Peak field strength in the selected Unit (V/m in the above picture)

Highest Peak frequency (Hz)

% of contribution to the WideBand result

When a limit is selected and activated, its compliance situation to the linear and quadratic ranges is shown in the two left bottom boxes.

Marker: you can place a marker anywhere on the spectrum display with a mouse click

Shown parameters:

Field strength at Marker frequency in the selected Unit

Marker frequency (Hz)

% of contribution to the WideBand result

In this area you can select which trace to place the Marker onto: specific axis (X,Y,Z) or Total result. Traces of single axis can be displayed, or not, according to **Show X-Y-Z** command.

Three buttons, to easily position marker over peaks, and a dedicated button, **Marker Center**, to change automatically sweep parameters in order to obtain, as center frequency, the actual marker position.
If activated, **Limit** checkbox allows displaying of the Limit value corresponding to the Marker frequency.

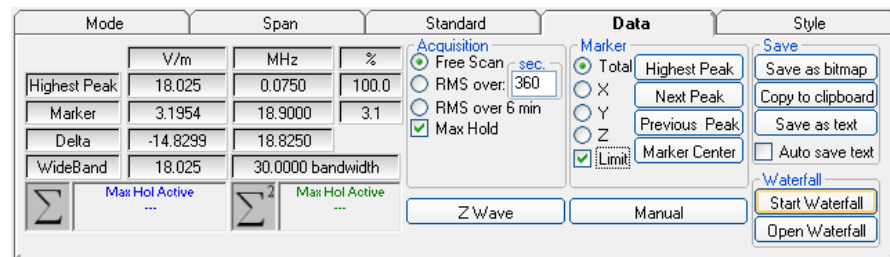
Delta: Difference in Field strength (expressed in dB) and frequency (Hz) between Highest Peak and Marker

WideBand: integration over the displayed frequency band

Shown parameters:

Field strength in the selected unit calculated over the Bandwidth (Hz)

Four additional frames, Acquisition, Marker, Save and Waterfall, are included in the Data section:



Acquisition: spectrum is displayed in different acquisition modes.

Here is the choice between instantaneous reading and Root Mean Squared over a certain period, which is set in the proper box. A Max Hold function is also available. When the RMS is activated, a progressive bar appears showing, step by step, how many seconds are already taken into account for the calculation of the result.

Free Scan: instantaneous values are shown; the display is continuously updated with new instantaneous readings.

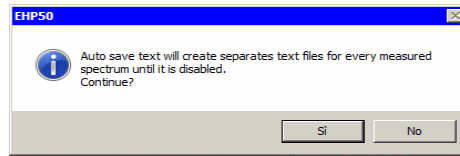
RMS over 6 min: square averaging calculated over 6 minutes time period as requested by several regulation for high frequency field measurement. This is a moving average. Once the first time period has been completed, oldest data is discarded to be replaced by the newest one showing thus the average value of the latest time period as specified.

RMS over: square averaging calculated over the specified time period (sec) is shown.

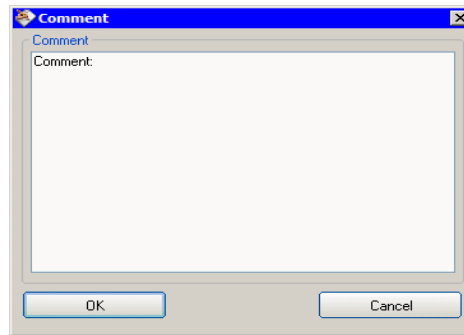
Max Hold: the maximum field strength value of each frequency step is retained and displayed since the Max Hold function has been activated. Every spectral line is therefore updated only if the new value is greater than the previously displayed one showing thus the Maximum of each spectral line since the Max hold function was activated.

Save: three buttons in this area to save spectrum as a picture file (.bmp), as a text file (.txt show extract example below) or to copy the spectrum picture to the Windows Clipboard.

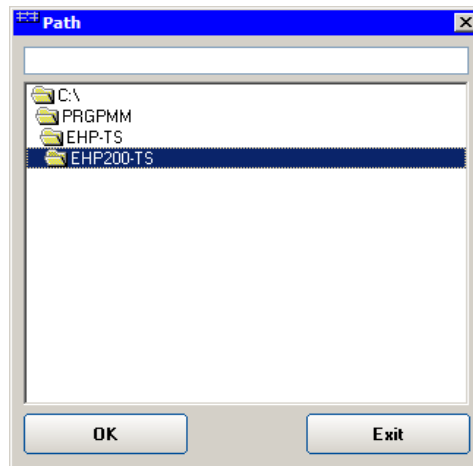
Auto save text: it is a functionality provided to automatically save a text file containing the measurements data and information.



It is also possible to insert a comment.



The user can select the path where the files will be stored.



The saved files will be structured as following:

| <ul style="list-style-type: none"> [-] EHP200-TS <ul style="list-style-type: none"> [-] 2014 <ul style="list-style-type: none"> [-] 08 <ul style="list-style-type: none"> [-] 27 [-] Uninstall [-] USB-WIN-96 [-] USB-WIN-XF [-] WIN-7 | <table border="1"> <thead> <tr> <th>Nome</th> <th>Ultima modifica</th> </tr> </thead> <tbody> <tr><td>12_20_13_20.TXT</td><td>27/08/2014 12:20</td></tr> <tr><td>12_20_15_92.TXT</td><td>27/08/2014 12:20</td></tr> <tr><td>12_20_19_00.TXT</td><td>27/08/2014 12:20</td></tr> <tr><td>12_20_21_72.TXT</td><td>27/08/2014 12:20</td></tr> <tr><td>12_20_24_43.TXT</td><td>27/08/2014 12:20</td></tr> <tr><td>12_20_27_14.TXT</td><td>27/08/2014 12:20</td></tr> </tbody> </table> | Nome | Ultima modifica | 12_20_13_20.TXT | 27/08/2014 12:20 | 12_20_15_92.TXT | 27/08/2014 12:20 | 12_20_19_00.TXT | 27/08/2014 12:20 | 12_20_21_72.TXT | 27/08/2014 12:20 | 12_20_24_43.TXT | 27/08/2014 12:20 | 12_20_27_14.TXT | 27/08/2014 12:20 |
|---|---|------|-----------------|-----------------|------------------|-----------------|------------------|-----------------|------------------|-----------------|------------------|-----------------|------------------|-----------------|------------------|
| Nome | Ultima modifica | | | | | | | | | | | | | | |
| 12_20_13_20.TXT | 27/08/2014 12:20 | | | | | | | | | | | | | | |
| 12_20_15_92.TXT | 27/08/2014 12:20 | | | | | | | | | | | | | | |
| 12_20_19_00.TXT | 27/08/2014 12:20 | | | | | | | | | | | | | | |
| 12_20_21_72.TXT | 27/08/2014 12:20 | | | | | | | | | | | | | | |
| 12_20_24_43.TXT | 27/08/2014 12:20 | | | | | | | | | | | | | | |
| 12_20_27_14.TXT | 27/08/2014 12:20 | | | | | | | | | | | | | | |

Under the selected folder (EHP200-TS in the example) a folder will be created and called like the current year (ex. 2014). Inside this folder, another one will be created and called like the current month (ex. 08, that is to say August). Again inside a folder will be created for each day of saving (ex. 27). The measurements will be in this last folder and their names will be in the format *hh_mm_ss_cc.TXT*

```

ENP200-TS Spectrum 19.02.20 16:47 Narda Safety Test Solutions
RBW: 10 kHz Span: 2.991MHz
WideBand: 8.1527 µT (0.0100 - 3.0000) MHz
Highest Peak 8.1527 µT @ 0.0100 MHz
Induced current density and electrical stimulation effects
--- ICNIRP 1998 COMPLIANT:91.817 % (0.0200 - 3.0125) MHz
Thermal considerations:
--- ICNIRP 1998 COMPLIANT:1.155 % (0.1000 - 3.0000) MHz
Acquisition: Free Scan
Limit: ICNIRP 1998 General Public

```

| Freq MHz | Total µT | X µT | Y µT | Z µT | Limit µT | C, L-Q |
|-------------|-------------|---------|---------|---------|-------------|--------|
| 0.0100 | 8.1527 | 5.0068 | 4.7437 | 4.3471 | 6.2500 | |
| 0.0125 | 1.9728 | 1.2134 | 1.1270 | 1.0720 | 6.2500 | |
| 0.0150 | 0.1839 | 0.1100 | 0.1100 | 0.0982 | 6.2500 | L |
| 0.0175 | 0.0167 | 0.0157 | 0.0039 | 0.0039 | 6.2500 | |
| 0.0200 | 0.0192 | 0.0079 | 0.0079 | 0.0157 | 6.2500 | |
| 0.0225 | 0.0118 | 0.0079 | 0.0039 | 0.0079 | 6.2500 | |
| 0.0250 | 0.0162 | 0.0079 | 0.0079 | 0.0118 | 6.2500 | |
| 0.0275 | 0.0147 | 0.0118 | 0.0039 | 0.0079 | 6.2500 | |
| 0.0300 | 0.0096 | 0.0039 | 0.0039 | 0.0079 | 6.2500 | |
| 0.0325 | 0.0096 | 0.0039 | 0.0039 | 0.0079 | 6.2500 | |
| 0.0350 | 0.0370 | 0.0079 | 0.0079 | 0.0353 | 6.2500 | L |
| 0.0375 | 0.2829 | 0.0589 | 0.0314 | 0.2749 | 6.2500 | L |
| 0.0400 | 1.0421 | 0.2160 | 0.1139 | 1.0131 | 6.2500 | L |
| 0.0425 | 2.3103 | 0.4548 | 0.2552 | 2.2422 | 6.2500 | L |
| 0.0450 | 3.6666 | 0.7893 | 0.4045 | 3.5577 | 6.2500 | L |
| 0.0475 | 4.5436 | 0.9896 | 0.5026 | 4.4060 | 6.2500 | L |
| 0.0500 | 4.7808 | 1.0524 | 0.5262 | 4.6337 | 6.2500 | L |
| 0.0525 | 4.4149 | 0.9660 | 0.4869 | 4.2803 | 6.2500 | L |
| 0.0550 | 3.4100 | 0.7461 | 0.3731 | 3.3064 | 6.2500 | L |
| 0.0575 | 2.0491 | 0.4477 | 0.2238 | 1.9970 | 6.2500 | L |
| 0.0600 | 0.8655 | 0.1846 | 0.0942 | 0.8404 | 6.2500 | L |
| 0.0625 | 0.2185 | 0.0471 | 0.0236 | 0.2121 | 6.2500 | L |
| 0.0650 | 0.0242 | 0.0039 | 0.0039 | 0.0236 | 6.2500 | L |
| 0.0675 | 0.0043 | 0.0013 | 0.0039 | 0.0013 | 6.2500 | |
| 0.0700 | 0.0089 | 0.0013 | 0.0079 | 0.0039 | 6.2500 | |
| 0.0725 | 0.0057 | 0.0039 | 0.0013 | 0.0039 | 6.2500 | |
| 0.0750 | 0.0043 | 0.0013 | 0.0013 | 0.0039 | 6.2500 | |
| 0.0775 | 0.0081 | 0.0013 | 0.0013 | 0.0079 | 6.2500 | |
| 0.0800 | 0.0022 | 0.0013 | 0.0013 | 0.0013 | 6.2500 | |
| 0.0825 | 0.0022 | 0.0013 | 0.0013 | 0.0013 | 6.2500 | |
| 0.0850 | 0.0057 | 0.0013 | 0.0039 | 0.0039 | 6.2500 | |
| 0.0875 | 0.0043 | 0.0013 | 0.0013 | 0.0039 | 6.2500 | |
| 0.0900 | 0.0096 | 0.0039 | 0.0079 | 0.0039 | 6.2500 | |
| 0.0925 | 0.0167 | 0.0118 | 0.0013 | 0.0118 | 6.2500 | |
| 0.0950 | 0.0309 | 0.0196 | 0.0039 | 0.0236 | 6.2500 | LQ |
| 0.0975 | 0.0391 | 0.0275 | 0.0039 | 0.0275 | 6.2500 | LQ |
| 0.1000 | 0.0397 | 0.0275 | 0.0079 | 0.0275 | 6.2500 | LQ |

Auto save text(.txt) extract example

The column C, L-Q show the contribution “C” linear “L” or “Q” quadratic used by the Sw to calculate the thermal or induced effects. The values on the column that are leaves blank are not used on the calculation.

Waterfall: press Start Waterfall to run the function, or Open Waterfall to load previously saved measurements.

4.6.1 Z wave

Z wave button: it can be selected only after complete scan in Hold When Done mode. The selected input must be Magnetic (mode A or B). When selected, the Zwave button shows the following display.

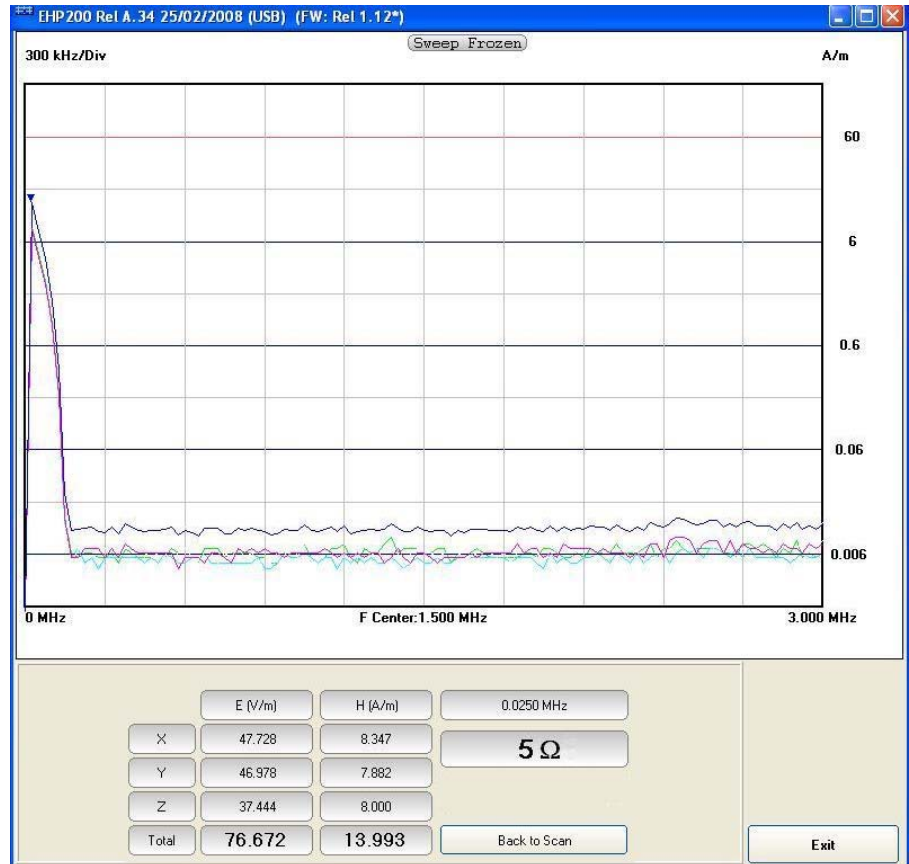


Fig.4-5 Z wave plot

It represents the 3 axis and total E and H field strength at the marker frequency.

The marker frequency is displayed in the upper position of the right column (0.0250 MHz in the previous picture).

The wave impedance (in this case 5 Ohm) is the ratio between Electric and Magnetic field at the marker frequency. It is used for evaluations in near field condition.

To prevent measurement errors the wave impedance is obtained by



the ratio $\frac{|E|}{|H|}$ at frequencies where both the fields are at least 10 dB above the noise floor of the instrument.

Back to Scan button: to close the wave impedance display and switching back to the control panel.

4.6.2 Manual

Press the **Manual** button to enter the Manual mode.

This is a different kind of view respect to the spectrum display.

The level of one frequency only, is shown for each sensor axis and total.

It is very fast and useful to analyse and monitor, in details, a single signal, or a small portion of band, without wasting time with the surrounding span.

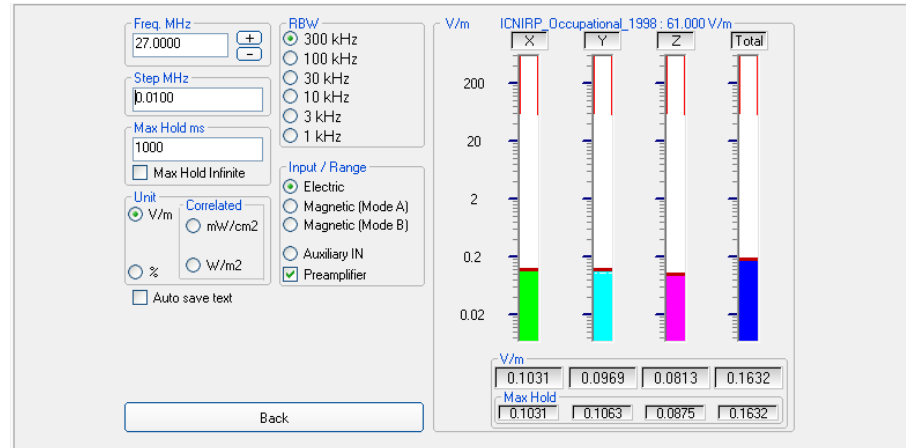


Fig.4-6 Manual mode

Freq. MHz: to easily set the exact tuning frequency, as in any signal receiver.

Step. MHz button: to set the frequency step used when searching for the right frequency with the + and – buttons.

Max Hold: the maximum field strength value is retained and displayed for the entered time length.

Unit: to select unit according to the Input setting. Unless a **Dual** mode has been selected, Power density units are correlated ones assuming measurement to be performed in far field condition.

RBW: six different settings for the Resolution Bandwidth filter. This setting affects the displayed noise floor (the higher RBW, the higher the noise and vice versa).

Depending on the tuned frequency, the RBW filter should be set as narrow as enough to avoid the spectrum analyzer 0Hz signal to be included in the measured bandwidth.

Input/Range: to select electric field, magnetic field in two different ranges, auxiliary input (50 Ohm input connector) and dual field mode in two different ranges.



Move the mouse cursor over “Magnetic” to display frequency range and level range of “Mode A” and “Mode B”.

Preamplifier: for best sensitivity when activated (vertical range changes accordingly).

Press the **Back** button to return to the main screen.

4.6.3 Waterfall

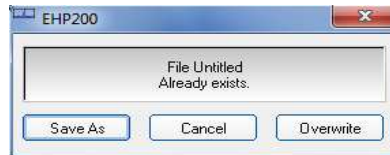
In addition to the spectrum view, another representation has been introduced in the software, commonly called Waterfall.

The advantage of this view is that the disturbances are shown in a tridimensional plot. Two dimensions are, as usual, frequency and level, and the third is the time.

In this way it is possible to detect and track time-varying signals.

The ranges for Frequency and Level are the same as the Spectrum view.

When pressing the **Start Waterfall** button, a pop-up message can appear warning the operator if a file with the same name as the one in use, already exists.



Press **Save As** to maintain the original file, or **Overwrite** to cancel the old measurement with the starting new one.

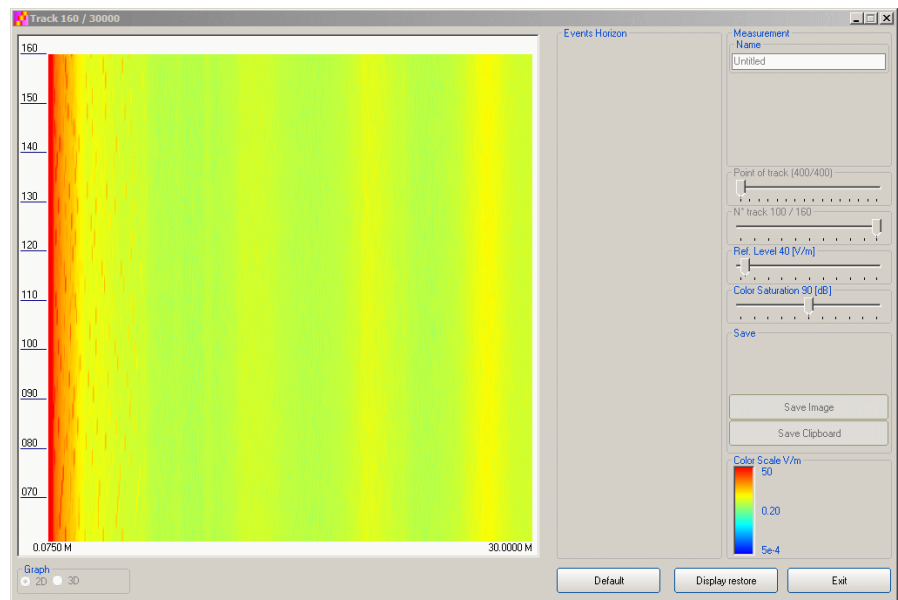


Fig.4-7 Waterfall - Graph 2D

In the **Graph 2D**, the horizontal axis represents Frequency, the vertical axis is the Time and the colour is the Level.

The signal amplitude is represented in a scale of arbitrary colours, usually the darker the lower and the brighter the higher, like in thermography.

The Color Scale referenced to levels and units, is indicated on the right bottom of the screen.

The status-bar shows the number of tracks already acquired and the maximum available.

On the right two sliders permit to set the preferred Reference Level and Color Saturation (level dynamic range).

Press the **Default** button to reload standard settings.

When entering the **Open Waterfall** function a screen similar to the following appears:

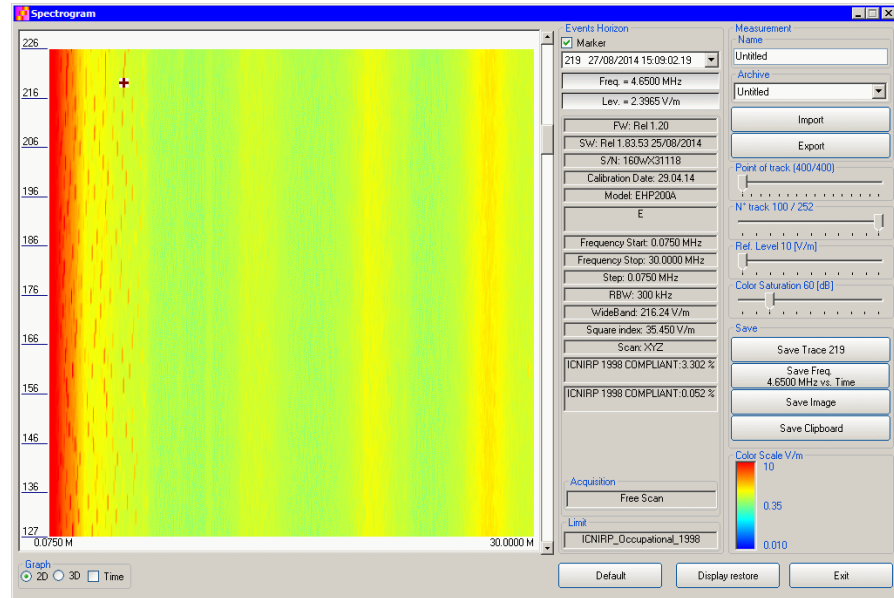


Fig.4-8 Waterfall Main Window

Like during the scan, on the left is the spectrogram of the measurements. The column in the middle, called Events Horizon, reports the Marker with its frequency and level and many parameters of the measurement setup and of the probe used.

On the right, in addition to Ref. Level and Color Saturation, there are two more sliders, useful to set the frequency resolution (Point of Track) and the time interval (N° track).

It is also possible to Import or Export a full acquisition by pressing the corresponding button in the Archive box. The name of the measurement can be typed in the Name box and from the list it is possible to select an already saved one.

In the Save box two or four buttons (depending on the marker activation) can be pressed to save:

- a single trace (Levels vs Frequencies)
- a single Frequency (Levels vs Time)
- an image of the spectrogram
- the clipboard

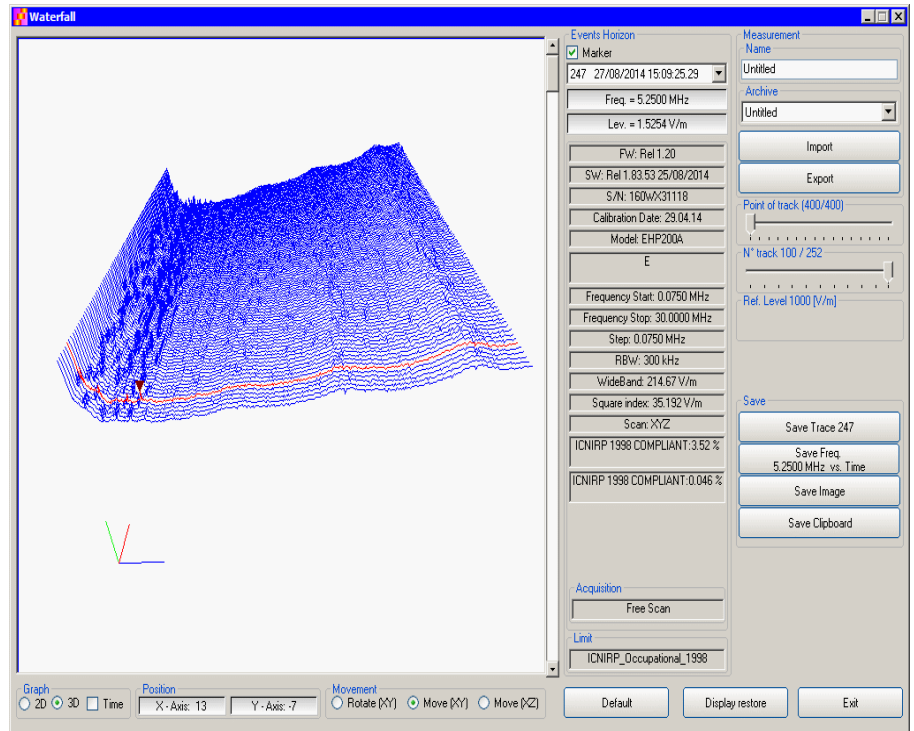


Fig.4-9 Waterfall - Graph 3D

In the **Graph 3D**, one axis (blue) represents Frequency, another the Level (green) and the third the Time (red). So the Frequency can be on the horizontal axis, the Level on the vertical axis and the Time in depth.

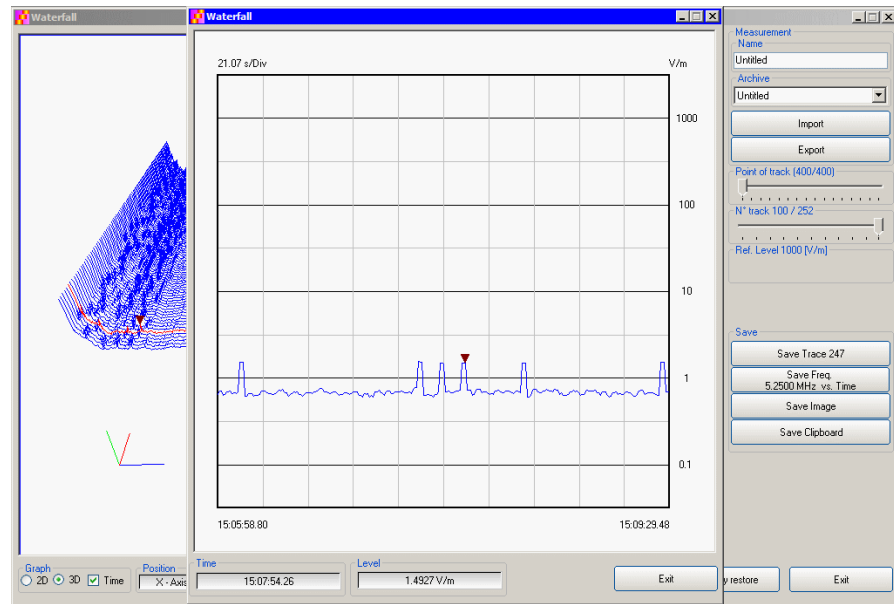
For this mode, another box, called **Movement**, will appear. Selecting the appropriate functions, you can move, rotate or zoom the view to your liking, using the mouse.

Another option of the **Graph 3D**, the Time plot, is available when the Marker is active.

Tick the Time label to enter this view.

A new window pops up and the plot represents the level at the marker frequency versus time.

The horizontal axis of the grid is the time and the vertical axis is the field level.



The Marker can be moved with the mouse to look for the desired frequency.

In the 3D view also the dynamic can be selected between 120 and 140 dB, to help for the best identification of disturbances.

4.6.3.1 Data recording

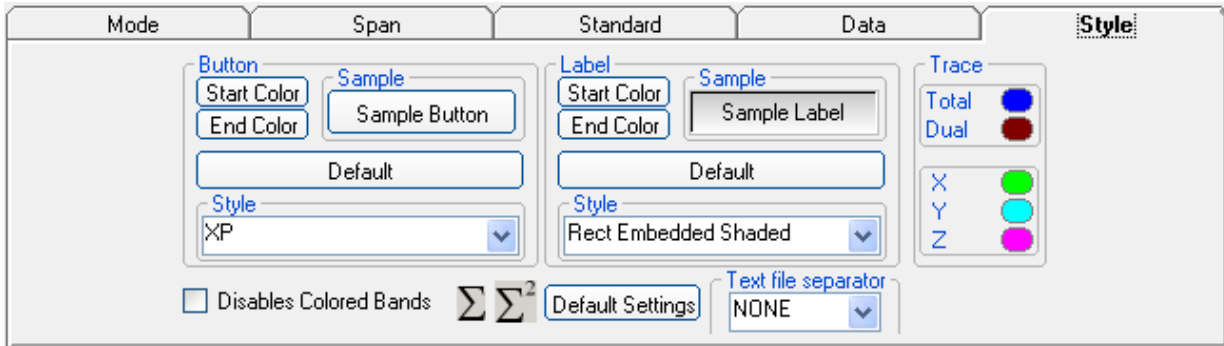
The subsequent spectra are automatically recorded and saved in a single file *.WF2 localized in the folder Waterfall in the program root, inclusive of all the analyzer settings.

The stored files can be recalled when in Data mode or at startup entering the Open Waterfall window.

The filename is set by the operator prior to starting the test and it is indicated at the upper right corner of the Waterfall window.

The maximum number of spectra that can be recorded is of 30000 and it is indicated, together with the current track number, in the status bar of the Waterfall window.

4.7 Style section: This unit concerns the appearance of the program.



Button and label style can be selected from a **Style** list

Start and **End Color** button allow selection from a color palette

Sample Button and **Sample Label** show the appearance preview

Default button to set appearance to the default parameters

Trace to set trace colours by means of the colour palette

Text file separator allow to specify column separator

Tick the **Disable colored bands** box to avoid highlighting the bands for which the software calculates the ICNIRP values.

Press **Default Settings** button to completely restore the initial aspect.

4.8 Additional functions provided by EHP200-TS

EHP-200A/AC electromagnetic field analyzer provides Electric and Magnetic field selective measurement in the 9kHz – 30MHz frequency range (**EHP-200A**) or in the 3kHz – 30MHz frequency range (**EHP-200AC**).

Even though there is no difference from EHP-50G regarding minimal physical overall dimensions and sensor positioning, a high frequency selective receiver is housed within this product. Additional settings and functions are therefore available.

Regarding settings, Span can be set as desired within the entire frequency range and required RBW filter can be selected down to 1kHz allowing thus optimum selectivity.

As requested by reference standards, Average value can be automatically calculated over 6 minutes as well as over customer definable time periods.

An important advantage, which is provided thanks to the Dual (E and H), Tri-axial sensor technology implemented in EHP-200A/AC is the new concept of power density calculation which, unlike common practice, makes use of both E and H real measurements providing thus accurate results which are still valid in both near and far field conditions.

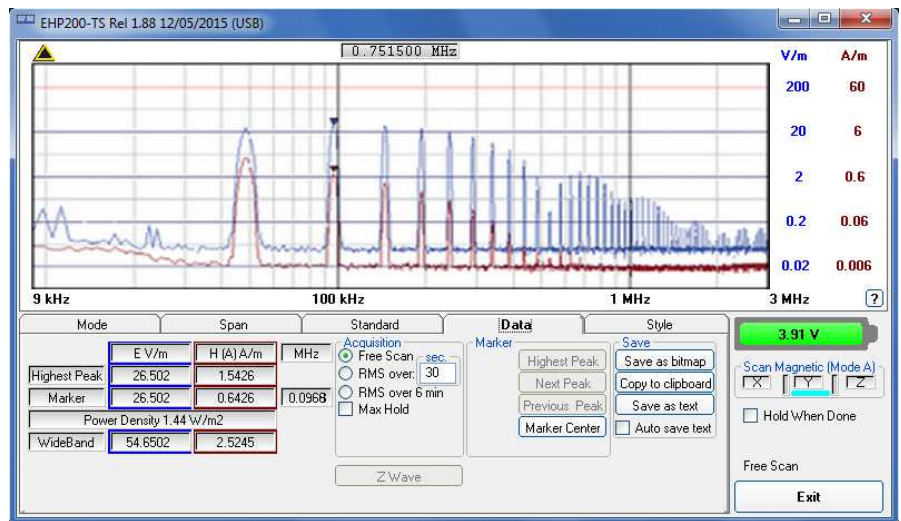


Fig.4-10 Both electric and magnetic fields displayed on the same graph.

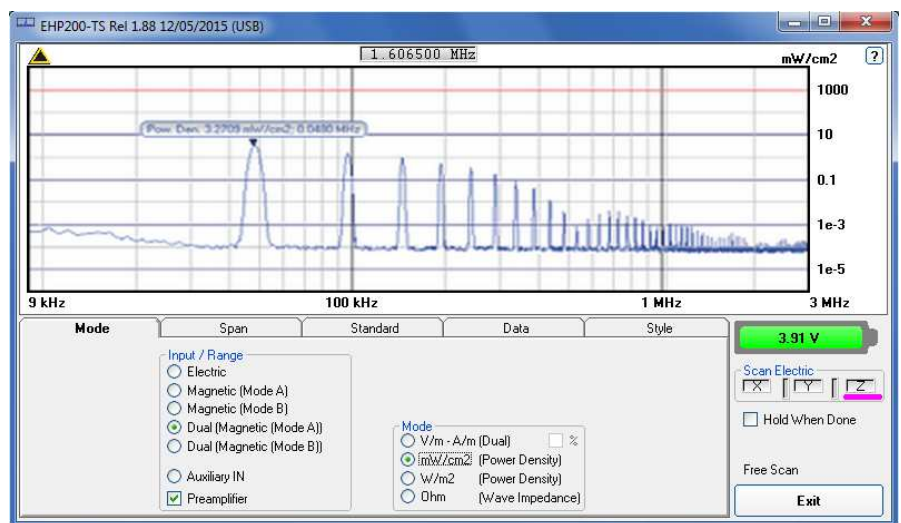


Fig.4-11 Power density spectrum is calculated over real electric and magnetic field measurement and therefore applicable to both far and near field conditions.

New wave impedance function is provided too by selecting the Ohm unit. This function automatically searches and displays result at frequencies showing effective field ratio calculation.

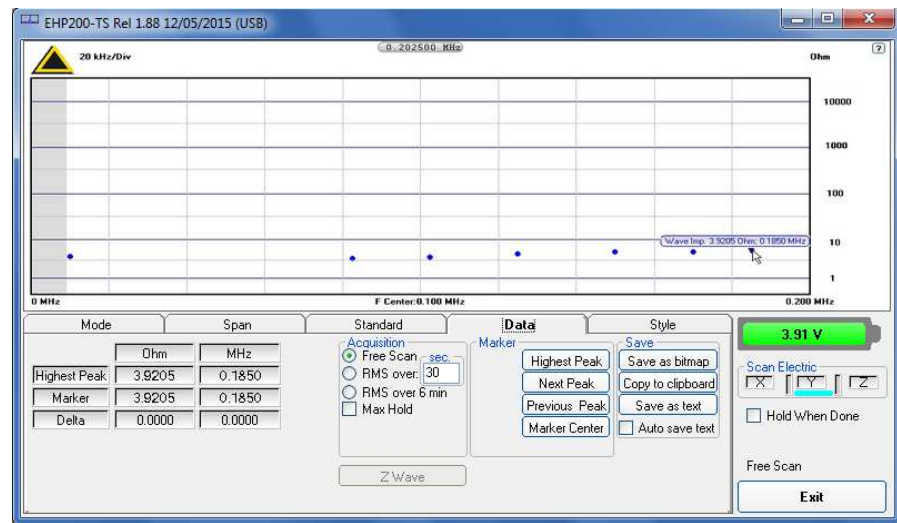


Fig.4-12 New wave impedance function



To prevent measurement errors the wave impedance is obtained by the ratio $\frac{|E|}{|H|}$ at frequencies where both the fields are at least 10 dB above the noise floor of the instrument.

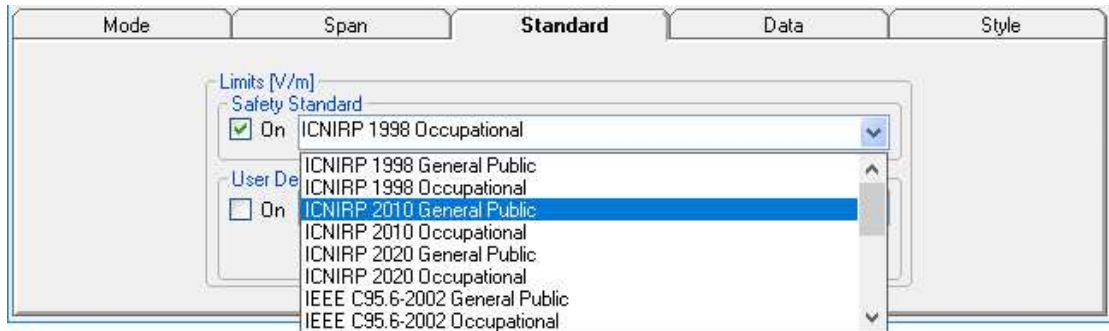
4.9 ICNIRP

One of the purposes of the **International Commission on Non-Ionizing Radiation Protection** is to establish guidelines for limiting EMF exposure that could affect human health.

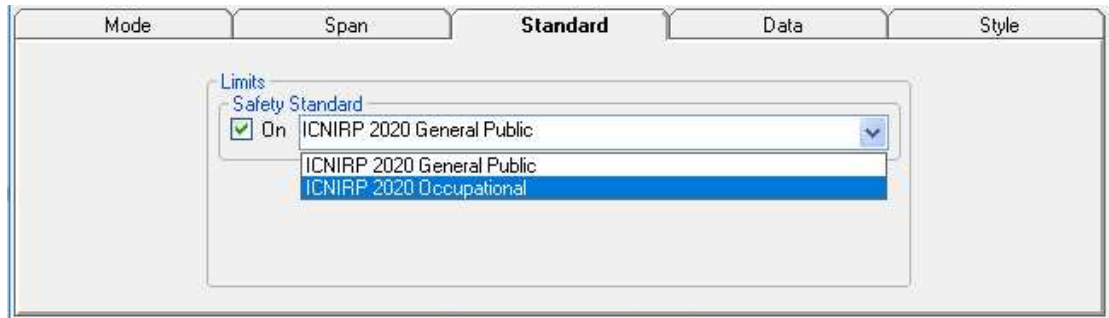
Standard section allows selecting **standard ICNIRP limits**, already included by the software installation.



The calculation of the ICNIRP value is performed if all three axes are enabled.



The ICNIRP 2020 General Public and Occupational limit can be activated only in **Dual Mode**.



The 2020 Guidelines for limiting exposure to electromagnetic fields have different reference levels than the 1998 and 2010 versions and specify a new procedure for calculating the weighted sum.

The formula is such that the ratio of the sum of the squares of the individual contributions (electric and magnetic field) to the reference levels.

The EHP-200A/AC takes advantage of its "Dual" mode to analyze both the electric field and the magnetic field and measure their contributions over the different frequencies.

When one of the **ICNIRP limits** is selected, the software automatically calculates the corresponding total integration of the measured signals, and compares the result with the threshold set by the standard, considering whether it is or is not exceeded.

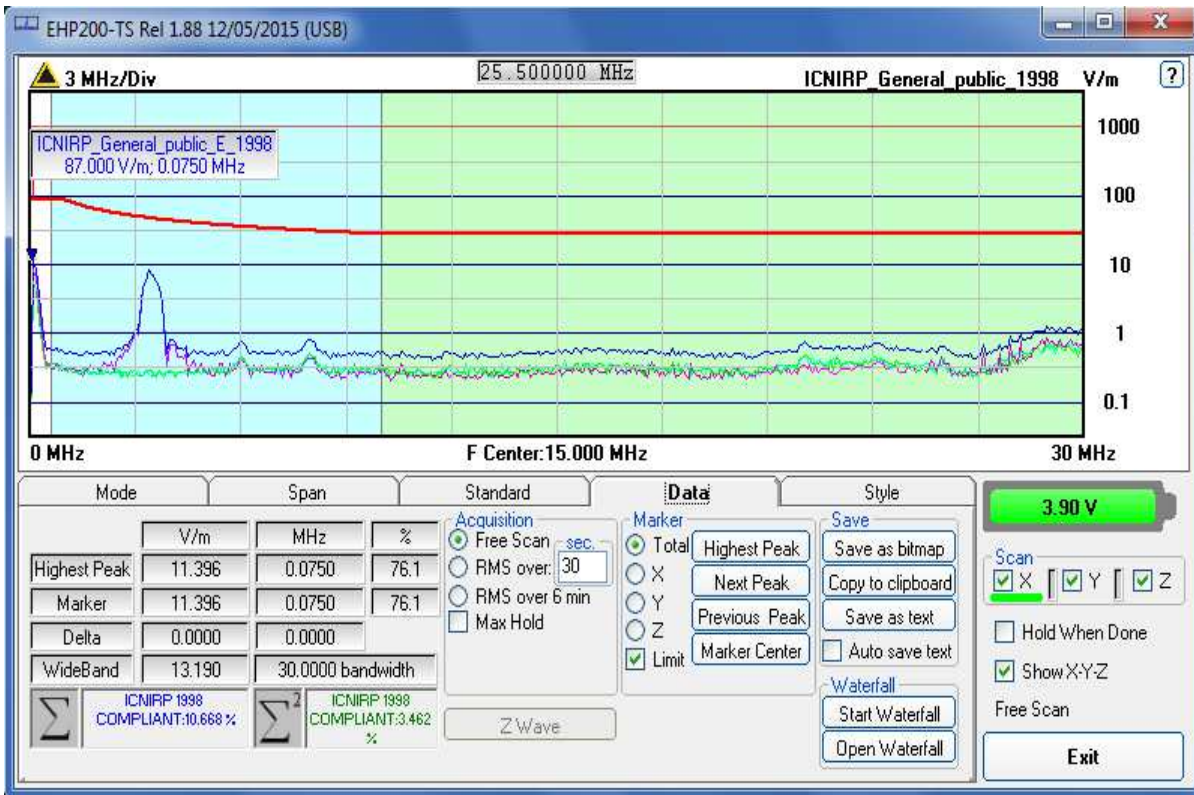
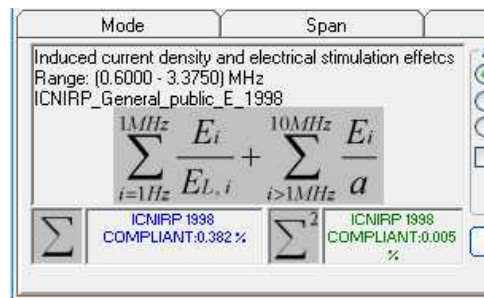


Fig.4-13 ICNIRP 1998 General Public limit selected

Moving the mouse cursor above the ICNIRP box located on the left bottom, the integration formula is shown.



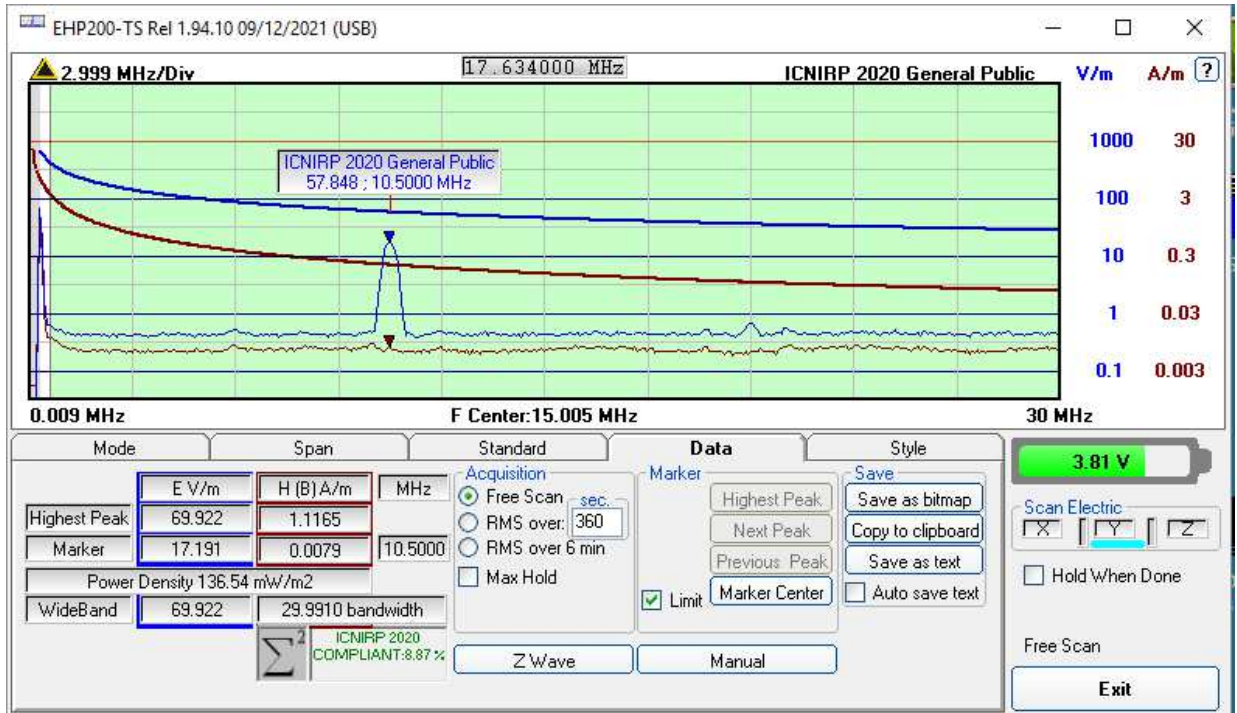
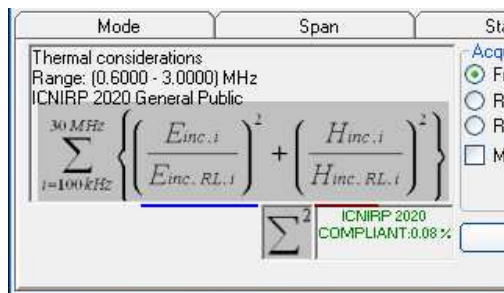


Fig.4-14 ICNIRP 2020 General Public limit selected

Moving the mouse cursor above the ICNIRP box located on the left bottom, the integration formula is shown.



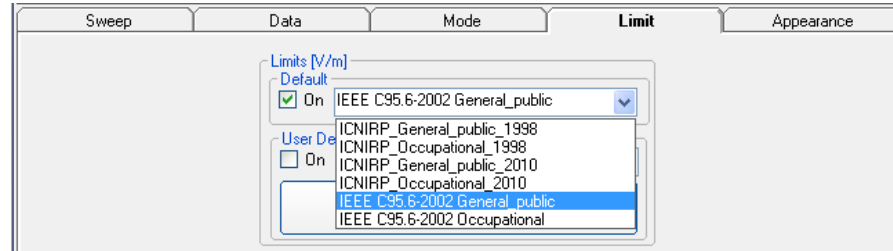
4.10 IEEE

One of the purposes of the **Institute of Electrical and Electronic Engineers, Inc. ("IEEE")** is to establish exposure standards.

Limit section allows the user to select **standard IEEE limits**, already included by the software installation.



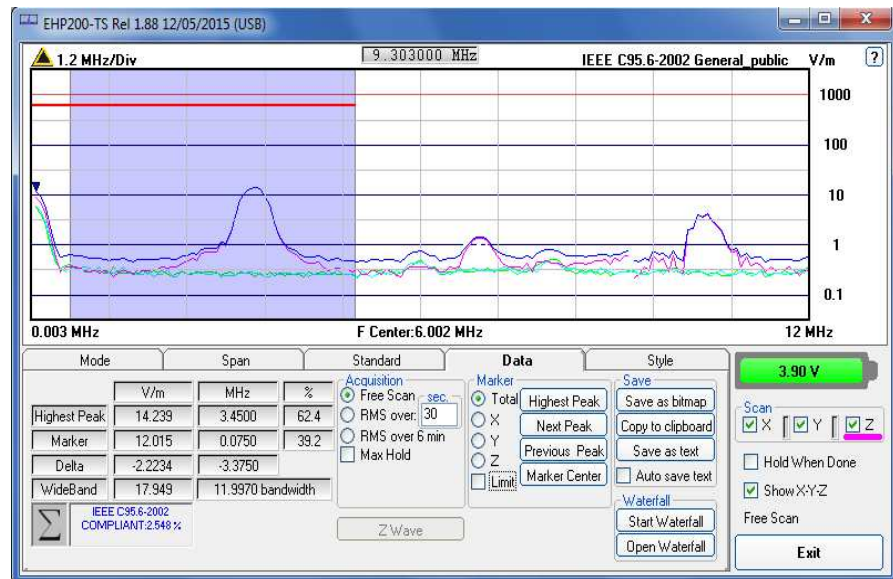
The limit cannot be activated when using Dual Mode.



When the **IEEE limits** is selected, the software automatically calculates the corresponding total integration of the measured signals, and compares the result with the threshold set by the standard, considering whether it is or is not exceeded.

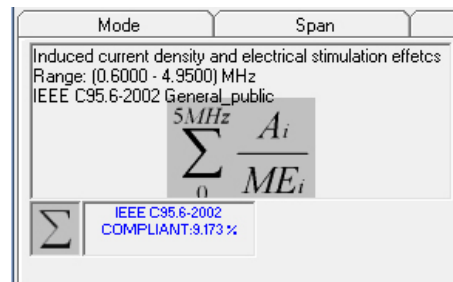


With coherent signals the result can be overestimated.



The calculation of the IEEE value is performed if all three axes are enabled.

Moving the mouse cursor above the ICNIRP box located on the left bottom, the integration formula is shown.



5 – Update Firmware

5.1 Update firmware

The EHP-200A/AC internal firmware can be updated easily by the user itself.

This section provides all the information required for firmware updating.

The Update Firmware Program is available after EHP200-TS package installation.

5.2 To run the update software

Turn off the EHP-200A/AC and connect it to a free USB or RS232 port of the PC.

Run **EHP200 Update Firmware** to start the update program.



Ensure that the batteries are fully charged before starting the upgrade.

5.3 To transfer data

Main window displayed after the updating program **EHP200 Update Firmware** has been run:



Fig.5-1 EHP-200A/AC Upgrading Utility Main Window

Select USB or RS232 communication port.

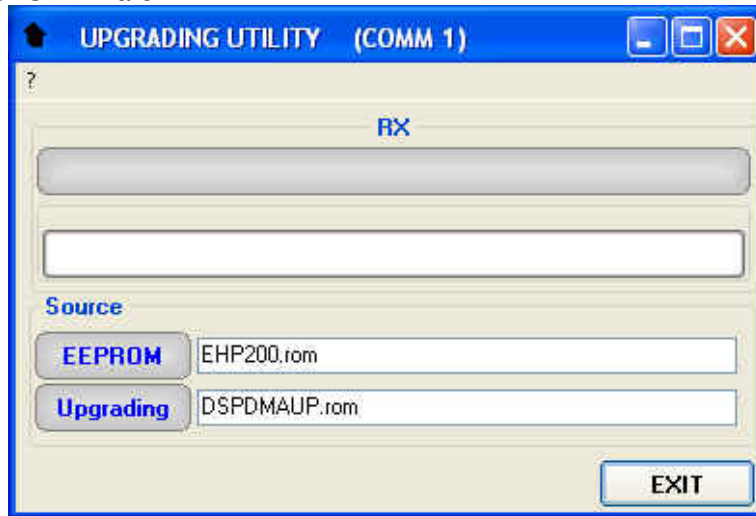
Before selecting RS232 port, choose the COM port used.



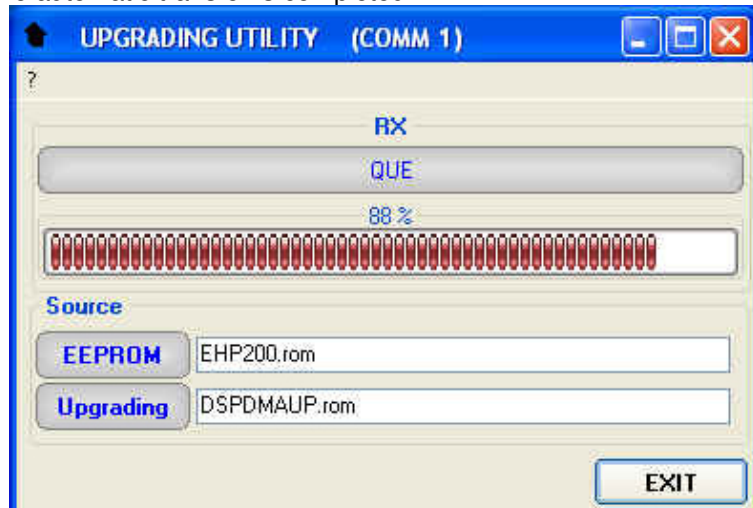
In case the software does not detect any EHP-200A/AC in the USB port, the following message will be displayed.



As soon the connection is established, the program is ready to update EHP-200A/AC firmware.



To start the process simply switch EHP-200A/AC on and wait (few minutes) until the automatic transfer is completed.



At the end, a message informs if the update has been successfully performed.

Turn the EHP-200A/AC **OFF** (it seems already OFF but it is not) and turn it **ON** again.

The EHP-200A/AC is now updated with the new version of the internal firmware.

It is now possible to disconnect the cable connected to the PC, with the EHP-200A/AC meter either switched on or off.

Subsequently, when the meter is switched on again, the new version of the firmware will be displayed in the 8053 DISPLAY or EHP200-TS Software.



To obtain firmware or programs updates for EHP-200A/AC, please contact your NARDA distributor or download it directly from the NARDA Web site <http://www.narda-sts.it>

This page has been intentionally left blank

6 – Uninstalling Software

6.1 Uninstalling EHP200-TS Software

It is possible to remove the EHP200-TS software from the PC according to the following procedure:

Run the Uninstall EHP200-TS utility.



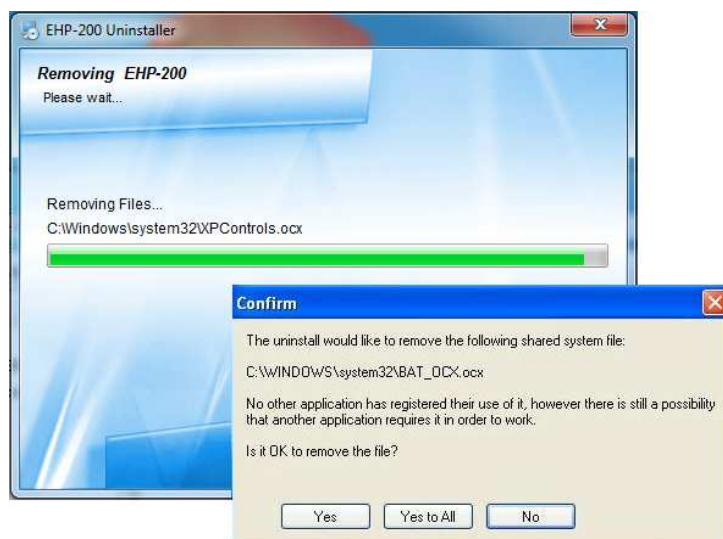
Follow the uninstaller instructions.

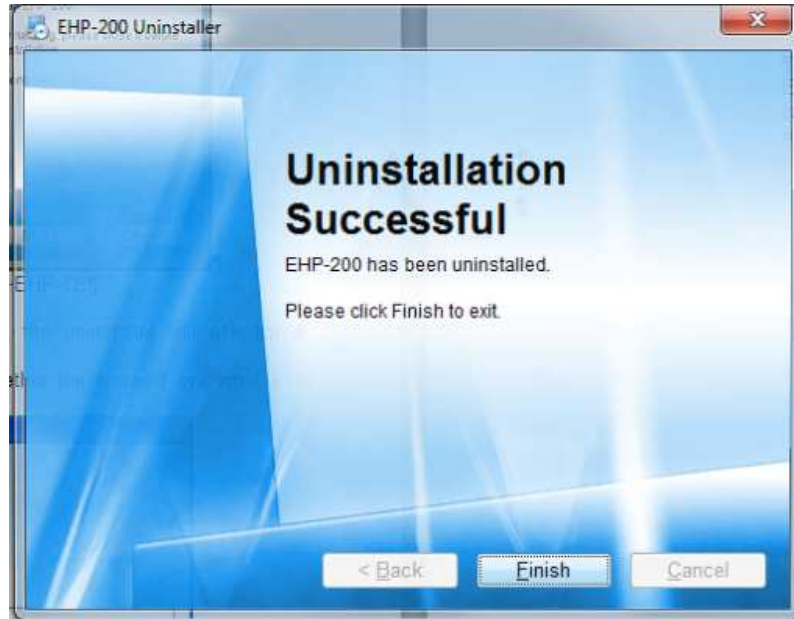


Fig.6-1 Uninstalling EHP200-TS

Before removing any shared system file, the uninstaller will ask for a confirmation.

Answer “NO” in case you are not sure whether the showed system file is required for other applications.





EHP200-TS software is now removed from the system, click “Finish” to close uninstaller utility.

7 – Uninstalling USB-OC

7.1 Uninstalling driver for USB-OC It is possible to remove the USB-OC driver from the PC according to the following procedure.

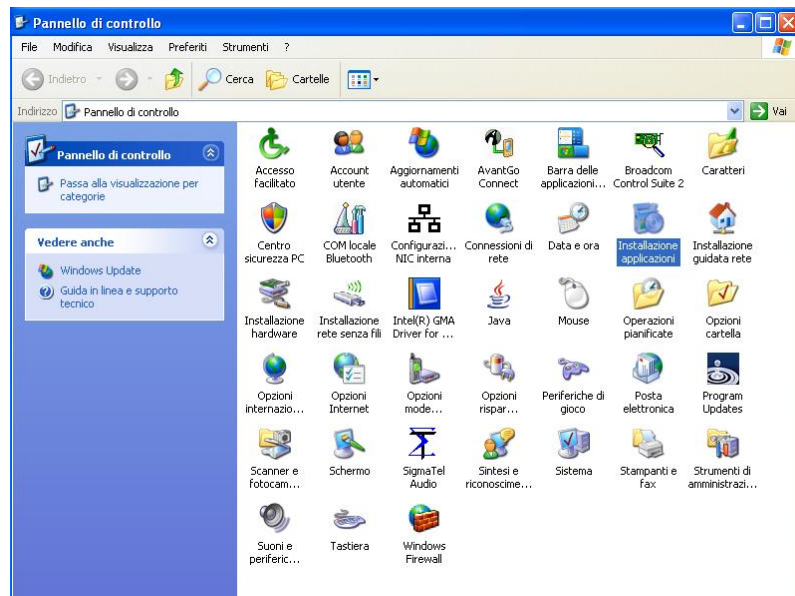
Open the Windows Control Panel.



The following procedure shows how to remove the driver in Windows XP environment. It may be different depending on the operating system in use.



Double click “Application Installation”.



From the application list select “FTDI FTD2XX USB Drivers” and click “Change/Remove”.

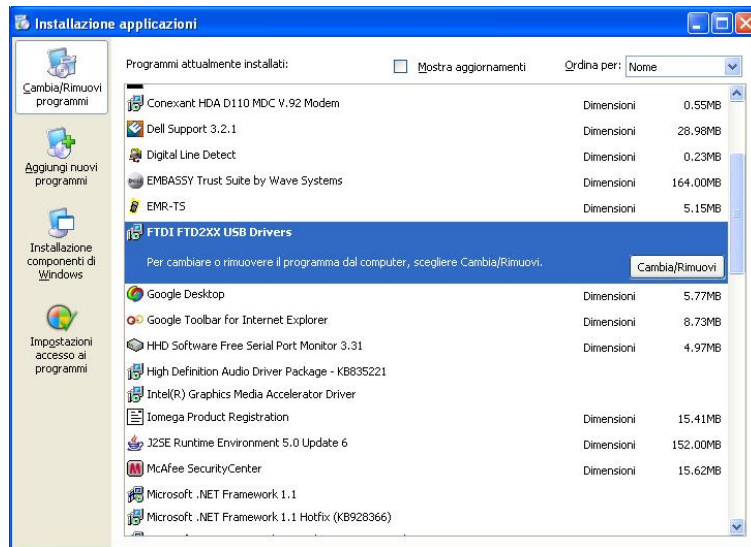
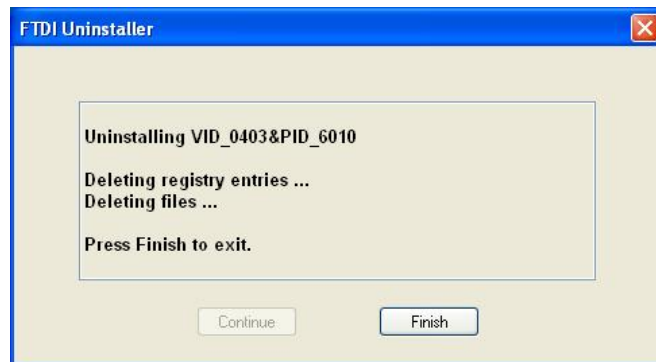


Fig. 7-1 Uninstalling USB-OC

Unplug the USB-OC converter, if connected, and click “Continue”.



Click “finish” to exit the uninstaller, USB driver is now removed from your system.

8 - Accessories

8.1 Introduction

This section provides the information required for installing and using the accessories of the EHP-200A/AC Analyzer.

Information is included regarding initial inspection, power requirements, interconnections, work environment, assembly, cleaning, storage and shipment.

The following general information is applicable to all accessories.

8.1.1 Preliminary inspection

Inspect the packaging for any damage.

If the packaging or anti-shock material have been damaged, check that the contents are complete and that the product has not suffered electric or mechanical damage.

NOTICE

Check that all the Accessories are there against the checklist found with the apparatus.

Inform the carrier and NARDA of any damage that has occurred.

8.1.2 Work environment

Unless otherwise specified, the work environment of the Accessories, must come within the following conditions:

- Temperature From -10°C to +50° C
- Humidity < 90% relative

The Accessories must be stored in a clean and dry environment, free from dust, acids and humidity.

The storage environment must come within the range of the following conditions:

- Temperature From -20°C to + 70° C
- Humidity < 95% relative

8.1.3 Return for repair

When the Accessories need to be returned to NARDA for repair, please complete the questionnaire appended to this User's Manual, filling in all the data that will be useful for the service you have requested.

For reducing the period of time required for the repairs, it is necessary to be as specific as possible in describing the problem. If the problem only occurs in certain circumstances, please describe in detail how it happens.

If possible it is better to reuse the original packaging; making sure that the apparatus is wrapped in thick paper or plastic.

Otherwise, use strong packaging by using a sufficient quantity of shock absorbent material around all sides of the product to ensure that it is compact and does not move around inside the package.

In particular, take every precaution to protect the front panels.

Finish the package by sealing it up tightly.

Apply a FRAGILE label to the package to encourage greater care in its handling.

8.1.4 Cleaning

Use a dry, clean and non-abrasive cloth for cleaning the instruments.

NOTICE

Do not use solvents, acids, turpentine, acetone or other similar products for cleaning the devices in order to avoid damaging them.

8.1.5 Power supply and battery chargers

All the accessories of EHP-200A/AC have a power system, which is autonomous from the mains and is supplied by either internal rechargeable batteries or directly from other devices to which they are connected.

The accessories use the same battery charger supplied with the meter. The 8053-BC battery charger can be used with a power frequency at either 50 Hz or 60 Hz with a supply voltage between 100 and 240 AC Volt. It can be supplied with different connectors to the supply mains in accordance with the various national standards.

The connector to the mains supply is fitted to the battery charger, to substitute it just disconnect it and fit the new connector.

To have the greatest autonomy, a full recharging cycle should be carried out before using the Accessories.

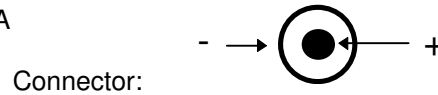


NOTE

ALWAYS connect the battery charger to the power supply BEFORE connecting to the Charge input of the Accessories.

The battery charger has an internal protective circuit that will limit the output of current if there is any load when connecting to the mains.

Battery charger:
output: DC, 10 - 15 V, ~ 560 mA



NOTE

In order to safeguard the features of the batteries, it is crucial to have a complete recharge before storing them for periods longer than 4 months. Therefore, it is warmly suggested recharging the batteries at least every 4 months even though the device has not been used.



NOTE

Updates of the software and firmware of the Accessories can be downloaded from the Web site <http://www.narda-sts.it> or requested directly from NARDA Sales Centres.

8.2

USB-OC Optical USB Converter

8.2.1 Introduction



USB-OC is an standard accessory of the EHP-200A/AC Analyzer. It converts the signals of some of the system's accessories, which are only connected via fiber optic, into USB-compatible signals. It, therefore, makes it possible to link the following items up to the USB port of any Personal Computer to operate them in conjunction with specific application software and for firmware updating:

- EHP-50F Electric and Magnetic Field Analyzers, 1 Hz – 400 kHz
- EHP-200A Electric and Magnetic Field Analyzers, 9 kHz – 30 MHz
- EHP-200AC Electric and Magnetic Field Analyzers, 3 kHz – 30 MHz

Either USB-OC or 8053-OC is indispensable for updating the internal firmware of the above-mentioned items via a Personal Computer and the relative update software is available free-of-charge on NARDA's web site at <http://www.narda-sts.it>

8.2.2 Installation

Insert USB-OC in the connector of a free USB port of the PC, connect the fiber optic coming from the probe or other Accessories treating the locating key with care.

Considering the very low consumption of the device, the power required by USB-OC is taken directly from the USB port of the PC. This means no maintenance is needed.

| Table 8-1 Technical specifications of the USB-OC Optical USB Converter | |
|--|-----------------------------|
| Max. length of the fiber optic | 40 m (10m with EHP-200A/AC) |
| USB Connector | Type A Male |



The link between USB-OC and a HUB USB device or USB cable extension could not work properly. Connect the USB-OC to the PC directly.



Front view

Key:

Fiber optic connector



Rear view

Key:

USB Type A Male

Fig. 8-1 USB-OC adapters

Power supply

USB-OC is powered directly from the USB port of the PC.

8.3

8053-OC Optical RS232 Converter

8.3.1 Introduction



8053-OC is an optional accessory of the EHP-200A/AC Analyzer. It converts the signals of some of the system's accessories, which are only connected via fiber optic, into RS-232-compatible signals. It, therefore, makes it possible to link the following items up to the serial port of any Personal Computer to operate them in conjunction with specific application software and for firmware updating:

- EHP-50F Electric and Magnetic Field Analyzers
- EHP-200A Electric and Magnetic Field Analyzers
- EHP-200AC Electric and Magnetic Field Analyzers

Either 8053-OC or USB-OC is indispensable for updating the internal firmware of the above-mentioned items via a Personal Computer and the relative update software is available free-of-charge on NARDA's web site at <http://www.narda-sts.it>

8.3.2 Installation

Insert 8053-OC in the connector of a free serial port of the PC, connect the fiber optic coming from the probe or other Accessories treating the locating key with care.

Considering the very low consumption of the device, the power required by 8053-OC is taken directly from the serial port of the PC. This means no maintenance is needed.

Table 8-2 Technical specifications of the 8053-OC Serial Optical Converter

| | |
|---------------------------------------|-----------|
| Max. length of the fiber optic | 80 m |
| RS 232 Connector | 9 pin DB9 |



The energy available on the DB9 connector of some PC model could be not sufficient to guarantee a good link with 80 meter fiber.



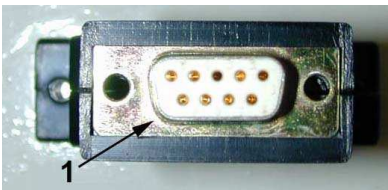
The energy available on the DB9 connector of some PC model could be not sufficient to guarantee a link with 8053-OC. In this case, is necessary use 8053-OC-PS between the converter and PC.



Front panel

Key:

- 1 – Fiber optic connector



Rear panel

Key:

- 1 - RS232 female DB9 connector

Fig. 8-2 8053-OC Panels

Power supply

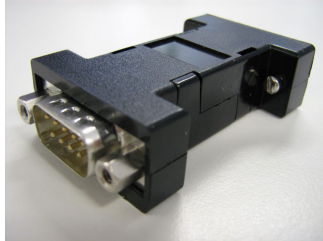
8053-OC is powered directly from the serial port of the PC.

8.4

8053-OC-PS Power Supply

8.4.1 Introduction

8053-OC-PS is an optional accessory of the EHP-200A/AC Analyzer.



8053-OC-PS is indispensable for some PC model does not have sufficient energy on the Serial Port to guarantee a link with 8053-OC.

8.4.2 Installation

Insert 8053-OC-PS in the connector of a free serial port of the PC or serial cable and connect the 8053-OC to 8053-OC-PS. To supply the 8053-OC-PS with 230Vac - 9Vdc Wall Adapter. Connect the fiber optic coming from the probe or other Accessories to 8053-OC.

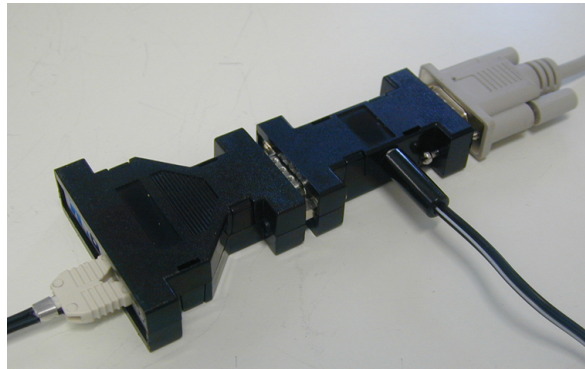


Table 8-3 Technical specifications of the 8053-OC-PS Power Supply

RS 232 Connectors

9 pin DB9



Front panel

RS232 male DB9 connector



Rear panel

RS232 female DB9 connector



Side panel

Supply male connector

Fig. 8-3 8053-OC-PS Connectors

Power supply

8053-OC-PS is powered through 230Vac - 9Vdc Wall Adapter.

8.5

8053 Display

8.5.1 Introduction

8053 DISPLAY is an Optional accessory of the EHP-200A/AC Analyzer. 8053 DISPLAY is a versatile and expandable test system suitable for measuring electric and magnetic fields relating to electromog. The system consists of various electric and magnetic field probes and of a compact and portable meter equipped with a wide LCD display, 4 simple function keys (which allow different actions and settings, in accordance with the selected menu), internal rechargeable batteries and RS232 and fiber optic interfaces. The system also has a wide range of Accessories, which have been designed for all the needs of the tests.

8.5.2 Standard accessories

The standard accessories included with 8053 DISPLAY are:

- Soft Carrying Case;
- Serial Cable (1.5m long);
- AC/DC Converter;
- Downloading & firmware update Software Media;
- 8053SW-02 Data acquisition software
- User's Manual;
- Calibration Certificate;
- Return for Repair Form.

8.5.3 Optional accessories

The following accessories may be ordered separately:

- FO-8053/10 Fiber Optic Cable (10m);
- FO-8053/20 Fiber Optic Cable (20m);
- FO-8053/40 Fiber Optic Cable (40m);
- FO-8053/80 Fiber Optic Cable (80m);
- FO-10USB Fiber Optic Cable (10m);
- TR-02A Tripod with Swivel;
- TT-01 Fiber Glass Telescopic Support;
- 8053-CC Rigid Carrying Case;
- 8053-CA Car Adapter;
- 8053-BC Additional Battery Charger;
- 8053-OC Optical Converter;
- USB-OC Optical Converter;
- 8053-RT Remote Trigger;
- EHP-50G Electric and Magnetic field Probe – Analyzer
- EHP-200A Electric and Magnetic field Probe – Analyzer
- EHP-200AC Electric and Magnetic field Probe – Analyzer



To allow a correct support of the EHP200A new features it is essential the 8053 runs the latest internal firmware revision. The release should be the 3.16 or higher.



To obtain firmware or programs updates for 8053 and EHP-200A, please contact your NARDA distributor or download it directly from the NARDA Web site <http://www.narda-sts.it>

8.5.4 Main specifications

Table 1-1 lists the specifications of 8053 DISPLAY. The specifications of all accessories are listed in the Chapter on Accessories.

The following conditions apply to all specifications:

- Temperature for use must be between -10°C and +40°C.

TABLE 8-4 Technical Specifications of 8053 DISPLAY

| | |
|----------------------------------|---|
| Frequency range | Depending on the probe |
| Dynamic range | >140 dB (depending on the probe) |
| Operating range | |
| Resolution | Depending on the probe (See Table 1-2) |
| Sensitivity | |
| Units | V/m, kV/m, $\mu\text{W}/\text{cm}^2$, mW/cm^2 , W/m^2 , A/m, nT, μT , mT; |
| LCD Display | |
| Field measured | X, Y, Z in absolute values, percent and total. |
| Time | Internal clock in real time |
| Probe | Display of the model and date of calibration |
| Graphic bar | The analog bar displays: - real time value with respect to full scale; - field versus time (in linear or logarithmic form) with automatic time scaling; - alarm threshold. |
| Measuring function | |
| Internal memory | Up to 32700 measurements (up to 8100 standard memory, up to 21600 extended memory) |
| Alarm | Variable threshold from 0 to 100% of full scale. Internal sound and blinking symbol on the display when the level is greater than the alarm threshold |
| Functions | |
| Averaging mode | Arithmetic, quadratic (RMS), manual, rolling and spatial |
| Averaging time | Definable 30 sec, 1, 2, 3, 6, 10, 15, 30 min or manual |
| Data acquisition (Logger) | Sampling mode (1, 10-900 sec/sample), data change, over the limit, average on 6 min, manual, spectrum (EHP-50 series) and Weighted Peak (EHP-50G only) |
| General specifications | |
| Output | LCD display 72x72mm 128x128 pixel, RS232 (with cable or fiber optic) |
| Input | Fiber optic connector |
| Internal battery | Rechargeable at NiMH (5 x 1,2 V) |
| Operational time | 24 hours normal mode, 48 hours (in SAVE MODE function: display off) |
| Recharge time | < 4 hours (15 minutes charge for 1 hour of use) |
| External power supply | DC, 10 - 15 V, I = about 500 mA |
| Interfaces | RS232 (calibration and firmware update) |
| Software/Firmware | Upgrade available via Internet at the Web site: http://www.narda-sts.it |
| Autotest | Automatic during switch-on of all functions; |
| Calibration | Inside the built-in E ² PROM of the probe |
| Conformity | With Directives 89/336 and 73/23 and the guide CEI 211-6 and 211-7 |
| Operating temperature | From -10 to +40°C |
| Storage temperature | From -20 to +70°C |
| Size (WxHxD) | 108 x 240 x 50 mm |
| Weight | 1.07 kg |
| Tripod support | Threaded insert 1/4" |

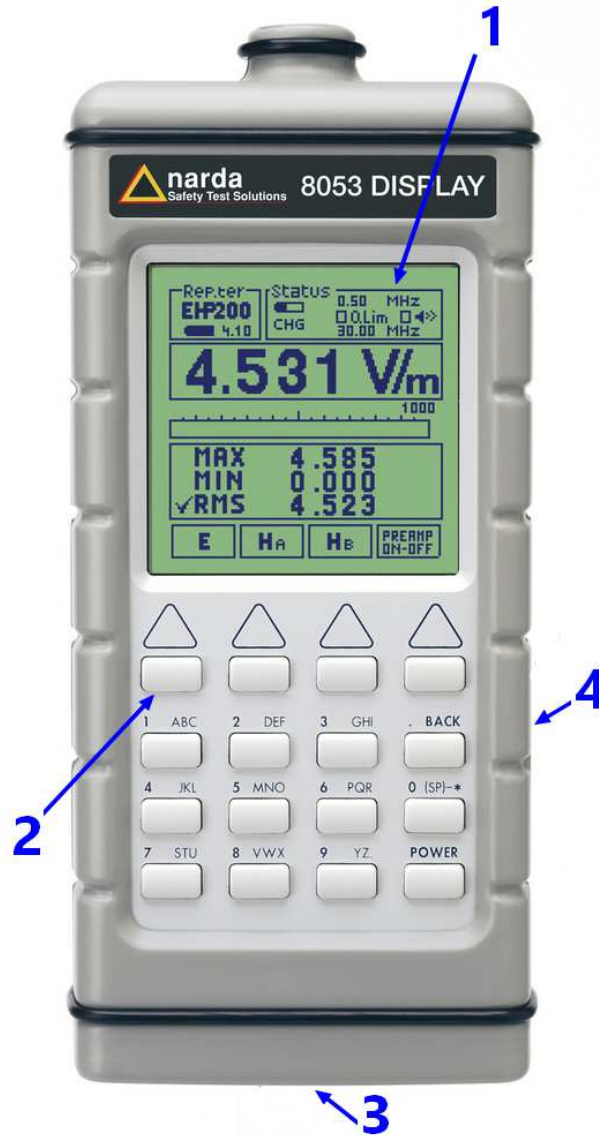
8.5.5 Field probes

Beside EHP-200A/AC, many other probes are available for using with 8053 DISPLAY, as for an example the powerful EHP-50G.

TABLE 8-5
EHP-50G Electric and Magnetic Field Probe – Analyzer, main characteristics.

| Field Probes | Frequency range | Level range | |
|--|-----------------|-------------------|----------------|
| | | Electric field | Magnetic field |
| Electric and Magnetic Field Analyzer EHP-50G | 1 Hz ÷ 400 kHz | 5 mV/m – 100 kV/m | 0.3 nT – 10 mT |

8.5.6 Front panel

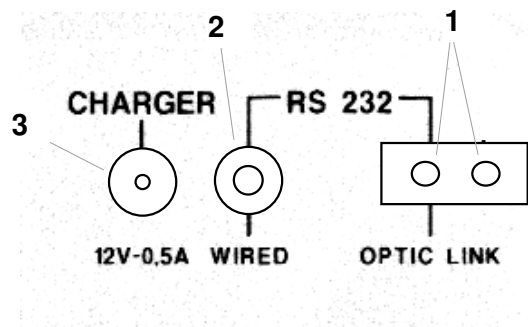


Key:

- 1 - Display
- 2 - Alphanumeric keyboard
- 3 – Tripod thread insert
- 4 – Side panel (see §8.5.7)

Fig. 8-4 Front panel

8.5.7 Side panel



Key:

- 1. Connection EHP200A/AC fiber optic link
- 2. Wired RS232 interface for PC connection
- 3. Battery charger connector (12V - 0.5A)

Fig. 8-5 Side panel

8.5.8 Battery charger

The battery charger supplied with the meter can work at either 50 Hz or 60 Hz with a supply voltage range between 100 and 240 Volt. It is supplied with different connectors to the supply mains in accordance with the various national standards.

8.5.9 To substitute the mains connector

To substitute the mains connector, simply remove the one installed on the battery charger and replace it with the one that is in compliance with its use.

8.5.10 To check the internal batteries

If the internal batteries are to have the greatest autonomy, we recommend that a full recharging cycle be carried out before using the meter.

To do this, go through the following procedure:

- Connect the battery charger to the power socket
- Link the output connector of the battery charger to the input **CHARGER** on the side panel of the meter
- 8053 DISPLAY will switch on automatically, after making a sound produced by the internal buzzer, the display will be activated and the meter will start its auto-check and begin the procedure for recognising the probes.
- The main window will therefore be activated and the status of the charge (**CHG**) of the battery will be displayed in the **STATUS** box

Indications of the battery in the STATUS box:

The status of the charge of the battery is displayed in the top left-hand corner of the **STATUS** box. The symbol of a small battery will be filled up proportion to the status of the battery charge.

The battery charger will be automatically stopped when one of the following occurs and a small connector will be displayed relating to a letter indicating the end of the recharging cycle.

Display of the following letters means:

V – The voltage of the batteries has reached 1.45 V/element (7.25 total), and therefore the recharging cycle is complete.

H – The recharging cycles has lasted for more than 4 hours.

T – The temperature of the batteries, compared to the temperature stored after ten minutes recharging, has increased more than 10 °C, or the temperature of the battery has reached 65 °C.

When the recharging cycle is finished, the 8053 DISPLAY is ready for use.



To avoid damage to the batteries, when the T symbol appears, the recharging cycle is stopped automatically.

To finish the recharging cycle wait for about ten minutes for the batteries to cool down then reconnect the battery charger.

Battery charger: DC, 10 - 15 V, ~ 500 mA



Connector:



ALWAYS connect the battery charger to the mains power BEFORE connecting the DC output to 8053 DISPLAY. The battery charger has an internal protective circuit that will not let it work if there is a load connected to the battery charger before the connection to the mains is activated.



In order to safeguard the features of the batteries, it is crucial to have a complete recharge before storing them for periods longer than 4 months. Therefore, it is warmly suggested recharging the batteries at least every 4 months even though the device has not been used.

8.6

TR-02A Tripod

8.6.1 Introduction



TR02A is an Optional Accessory of the EHP-200A/AC analyzer. It allows EHP-200A/AC Analyzer to be easily supported during field measurements. Each of these instruments has a securing screw, usually placed on the bottom part of its container, that enables it to be easily and quickly put into place through the 8053-SN swivel supplied with the tripod.

The design and materials of the TR-02A tripod have been specially selected to prevent it from disturbing the sensors and, therefore, the measurements taken.

The height of the tripod can be adjusted by means of its extendable legs and it is furnished with special feet that are able adapt to all surfaces thereby improving stability. The height of its central support can also be adjusted.

It is supplied with a small protective carrybag to make it easy to carry.

Table 8-6 Technical specifications of the TR-02A Tripod

| | |
|--------------------------|--------------------------------|
| • Legs | 3 legs x 3 extendable sections |
| • Transport size: | 76 x 12 x 12 cm |
| • Minimum height: | 60 cm |
| • Maximum height: | 180 cm |
| • Weight | 2.8 kg |
| • Load capacity: | 10 kg |
| • Tripod support | Threaded insert ¼ " |

Details of the mounting head of the central column of the support and its adjustments:

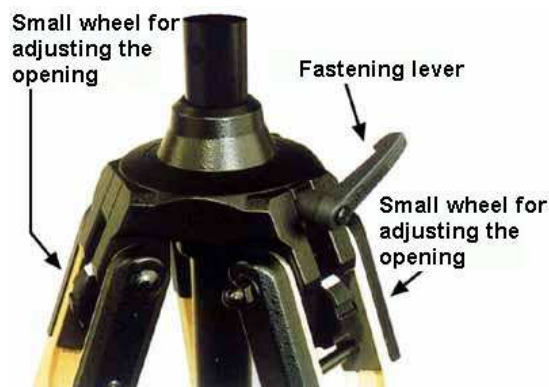


Fig. 8-6 TR-02A Tripod

The angle for opening each leg into three different positions can be adjusted by using special small adjustable wheels:

- fixed opening of 20°: White adjustment indicator is visible (as in the Fig. 8-6);
- fixed opening of 45°: Red adjustment indicator is visible;
- variable opening: no indicator is visible.

The central support can be adjusted and blocked by means of a special fastening lever.

Details of the swivel for fastening to the **8053-SN**:

- full height: 8 cm
- weight: 160 g
- load capacity: 10 kg
- Threaded insert 1/4 “

The adjustable swivel makes mounting and fastening the instrument easy as well as changing the angle in any directions via the locking knob.



8.7

TT-01 Fiber Glass Telescopic Support

8.7.1 Introduction

TT-01 is an Optional Accessory of the EHP-200A/AC Analyzer. It allows EHP-200A/AC Analyzer to be easily supported during field measurements.

This device, on the top part of its container, has a screw to fix the relative apparatus.

The design and materials of the TT-01 have been specially selected to prevent it from disturbing the sensors and, therefore, the measurements taken.

| Table 8-7 Technical specifications of the TT-01 Fiber Glass Telescopic Support | |
|--|--------|
| • Diameter | 32 mm |
| • Minimum height: | 120 cm |
| • Maximum height: | 420 cm |
| • Weight | 500 g |

TT-01 Fiber Glass Telescopic Support with soft carrying case



The height of the TT-01 can be adjusted.

Fig. 8-7 TT-01 Fiber Glass Telescopic Support

Other Accessories

Other Accessories are available on request with the EHP-200A/AC, such as car adapter, 12 V battery charger and Internal AC Plug Adapter.



9 - Software command protocol

9.1 Introduction

EHP-200A/AC commands allow the user to set the analyzer and query for data through the serial communication interface.

Communication protocol is the following:

- Baud: 38400
- Parity: NONE
- Length: 8 bit
- Bit Stop: 1

To allow operation with 8053-DISPLAY accessory, EHP-200A/AC is automatically set in “Master” mode at power ON.

Measurement data are continuously sent over the communication port regardless of received commands.



Since this operating mode might be not useful when interfacing to other software, the command #00v* can be sent to the analyzer to turn it in “Slave” mode; while operating in Slave mode, EHP-200A/AC send answers to the received commands according to the communication protocol described below.

To turn the EHP-200A/AC in “Master mode”, switch the probe off and then on again; it will be automatically set in Master mode at power ON.

The EHP-200A/AC automatically turns off 30 minutes after receiving a command to save battery.

9.2 Input select commands

| Name | Command | Description |
|------|--|---|
| AUX | "#00"+Chr(126)+"C"+Chr(7)+Chr(0)+"**" | Select Aux. input The answer is "C"<CR><LF> Example: "#00~C"+Chr(7)+Chr(0)+"**" |
| Ex | "#00"+Chr(126)+"C"+Chr(1)+Chr(0) + "**" | Select Electrical X axis input. The answer is "C"<CR><LF> Example: "#00~C"+Chr(1)+Chr(0)+"**" |
| Ey | "#00"+Chr(126)+"C"+Chr(2)+Chr(0) + "**" | Select Electrical Y axis input. The answer is "C"<CR><LF> Example: "#00~C"+Chr(2)+Chr(0)+"**" |
| Ez | "#00"+Chr(126)+"C"+Chr(3)+Chr(0) + "**" | Select Electrical Z axis input. The answer is "C"<CR><LF> Example: "#00~C"+Chr(3)+Chr(0)+"**" |
| Hxh | "#00"+Chr(126)+"C"+Chr(4)+Chr(0x80)+"**" | Select Magnetical X axis input. Mode A. The answer is "C"<CR><LF> Example: "#00~C"+Chr(4)+Chr(0x80)+"**" |
| Hyh | "#00"+Chr(126)+"C"+Chr(5)+Chr(0x80)+"**" | Select Magnetical Y axis input. Mode A. The answer is "C"<CR><LF> Example: "#00~C"+Chr(5)+Chr(0x80)+"**" |
| Hzh | "#00"+Chr(126)+"C"+Chr(6)+Chr(0x80)+"**" | Select Magnetical Z axis input. Mode A. The answer is "C"<CR><LF> Example: "#00~C"+Chr(6)+Chr(0x80)+"**" |
| Hx | "#00"+Chr(126)+"C"+Chr(4)+Chr(0x0)+"**" | Select Magnetical X axis input. Mode B. The answer is "C"<CR><LF> Example: "#00~C"+Chr(4)+Chr(0x0)+"**" |
| Hy | "#00"+Chr(126)+"C"+Chr(5)+Chr(0x0)+"**" | Select Magnetical Y axis input. Mode B. The answer is "C"<CR><LF> Example: "#00~C"+Chr(5)+Chr(0x0)+"**" |
| Hz | "#00"+Chr(126)+"C"+Chr(6)+Chr(0x0)+"**" | Select Magnetical Z axis input. Mode B. The answer is "C"<CR><LF> Example: "#00~C"+Chr(6)+Chr(0x0)+"**" |

9.3 Settings commands

| Name | Command | Description |
|--------|---|--|
| PreON | "#00"+Chr(126)+"A" + Chr(3) + "*" | Activate Preamplifier The answer is "C"<CR><LF> Example: "#00~A"+Chr(3)+"* |
| PreOFF | "#00"+Chr(126)+"A" + Chr(2) + "*" | De-Activate Preamplifier The answer is "C"<CR><LF> Example: "#00~A"+Chr(2)+"* |
| RBW | "#00(b" + Chr(48 + Index) + "*" INDEX= 0 ->300kHz 1 ->100kHz 2 ->30kHz 3 ->10kHz 4 ->3kHz 5 ->1kHz | Select filter. When the EHP-200A/AC receives this command the filter specified by Index parameter is selected. The answer is "#00(b" + Chr(48 + Index) Example: "#00(b1*" Set RBW filter to 100kHz The answer is "#00(b" + Chr(48 + Index) |
| Tune | "#00(t " + Freq+ "*" Freq is the frequency in Hz (can be expressed by a scientific notation). | Tuning Command for a single frequency. The EHP-200A/AC will be tuned and will read field value at the frequency specified by Freq parameter. Example: "#00(t 3256000*" tune to 3.256 MHz The answer is:"#00(t" + st |

9.4 Data request commands

| Name | Command | Description |
|---------|-----------|--|
| Field | "#00(v*" | Field value request on previously settled axis, frequency and RBW filter. For electric field the unit is V/m, for magnetic field is A/m, if AUX is selected as signal input then the unit is Volt (on 50 ohm); to convert to dBm calculate with: $P(\text{dBm})=20 * \text{Log}10(\text{Lettura}/223.6)$ Example: "#00(v*" Could answer with: ".421875*" |
| S/N | "#00?S0*" | Probe serial number request Example: "#00?S0*" Could answer with: "040WX90606*" |
| DateCal | "#00?S1*" | Probe last calibration date request Example: "#00?S1*" Could answer with: "09.07.09*" |

9.5 SWEEP Commands

| Name | Command | Description |
|----------|--|---|
| SetStart | <p>"#00(i" + startfreq *</p> <p>startfreq is the frequency in Hz (can be expressed by a scientific notation).</p> | <p>Sweep Start frequency. If there is a sweep runnin it will stop. The answer is the command echo without the *. Example: #00(i300000* set Sweep Start freq. to 300kHz Answer : #00(i300000</p> |
| SetStop | <p>"#00(f" + stopfreq *</p> <p>stoptfreq is the frequency in Hz (can be expressed by a scientific notation).</p> | <p>Sweep Stop frequency If there is a sweep runnin it will stop. The answer is the command echo without the *. Example #00(f3000000* set Sweep Stop freq. to 30MHz Answer: #00(f3000000</p> |
| SetStep | <p>"#00(s" + stepfreq *</p> <p>steptfreq is the frequency in Hz (can be expressed by a scientific notation).</p> | <p>Sweep Step frequency If there is a sweep runnin it will stop. The answer is the command echo without the *. Example: #00(s7500* set Sweep Step freq. to 7.5kHz Answer: #00(s7500</p> |
| DoSweep | <p>"#00(g**"</p> | <p>Data request for previous commands. (input, start, stop and step previously set).</p> <p>For input list please refer to "Input select commands" paragraph of this chapter.</p> <p>The answer will be like the table in the following page:</p> |

| Byte Position | Name | Description |
|---|-----------------|--|
| 1-11 | Header | The Header string is as follow: |
| 1 | Bat | Battery voltage. Integer, without sign, 8 bit. To convert to voltage apply the following formula: $Battery\ Voltage = Bat / 256 * 4.52$ |
| 2 | Chg | Battery charge status. Integer, without sign, 8 bit. Possible values are: <ul style="list-style-type: none"> • "0" (0x30) → battery charger NOT connected • "1" (0x31) → battery under charge • "2" (0x32) → battery charge completed <p>Note: with a battery voltage higher than 4.12 Volt AND Chg = 1 the battery charge should be considered completed.</p> |
| 3-11 | Res | Byte reserved to future use |
| From 12 to 5*(Stop-Start)/Step | Data Packet | The Data Packet string is as follow: |
| 12, 12+5*n | Sync | Integer, without sign, 8 bit. Used for synchronizing control purposes. Sync is the modulus 256 of the actual Step starting at the Start frequency (the Sync at Start frequency is = 1). Example of sweep with the following parameters: <ul style="list-style-type: none"> • Start=0 • Stop=30MHz • Step= 75kHz The result will be : <ul style="list-style-type: none"> • Sync=1 at 0 MHz (Byte 12). [(0/.075) mod 256 +1=0] • Sync=41 at 3 MHz (Byte 212). [(3/.075) mod 256 +1=41] • Sync=45 at 22.5 MHz (Byte 1512). [(22.5/.075) mod 256 + 1=45] |
| 13, 13+5*n | Exp | Integer, without sign, 16 bit., in the format HiLo, representing the exponent of the field value. |
| 15, 15+5*n | Mantissa | Integer, without sign, 16 bit., in formato HiLo, representing the mantissa of the field value. |
| <p>The field value is calculated with the following formula: $Fld = Kf * Mantissa * Sqr(2 ^ Exp) / 8$ where Kf is as following:</p> <ul style="list-style-type: none"> • Electric field E=0.125 • Magnetic field Mode A H=0.025 (EHP-200A) or H=0.075 (EHP-200AC) • Magnetic field Mode B H=0.0025 (2.5E-3) (EHP-200A) or H=0.0075 (7.5E-3) (EHP-200AC) • AUX V=0.0138 <p>When the Preampifier is active the coefficient Kf must be multiplied by 0.2</p> | | |

This page has been left blank intentionally

Caro cliente

grazie per aver acquistato un prodotto NARDA! Sei in possesso di uno strumento che per molti anni ti garantirà un'alta qualità di servizio. NARDA riconosce l'importanza del Cliente come ragione di esistenza; ciascun commento e suggerimento, sottoposto all'attenzione della nostra organizzazione, è tenuto in grande considerazione. La nostra qualità è alla ricerca del miglioramento continuo. Se uno dei Suoi strumenti NARDA necessita di riparazione o calibrazione, può aiutarci a servirla più efficacemente compilando questa scheda e accludendola all'apparecchio.

Tuttavia, anche questo prodotto diventerà obsoleto. In questo caso, ti ricordiamo che lo smaltimento dell'apparecchiatura deve essere fatto in conformità con i regolamenti locali. Questo prodotto è conforme alle direttive WEEE dell'Unione Europea (2002/96/EC) ed appartiene alla categoria 9 (strumenti di controllo). Lo smaltimento, in un ambiente adeguato, può avvenire anche attraverso la restituzione del prodotto alla NARDA senza sostenere alcuna spesa. Può ottenere ulteriori informazioni contattando i venditori NARDA o visitando il nostro sito Web www.narda-sts.it.

Dear Customer

thank you for purchasing a NARDA product! You now own a high-quality instrument that will give you many years of reliable service. NARDA recognizes the importance of the Customer as reason of existence; in this view, any comment and suggestion you would like to submit to the attention of our service organization is kept in great consideration. Moreover, we are continuously improving our quality, but we know this is a never ending process. We would be glad if our present efforts are pleasing you. Should one of your pieces of NARDA equipment need servicing you can help us serve you more effectively filling out this card and enclosing it with the product.

Nevertheless, even this product will become obsolete. When that time comes, please remember that electronic equipment must be disposed of in accordance with local regulations. This product conforms to the WEEE Directive of the European Union (2002/96/EC) and belongs to Category 9 (Monitoring and Control Instruments). You can return the instrument to us free of charge for proper environment friendly disposal. You can obtain further information from your local NARDA Sales Partner or by visiting our website at www.narda-sts.it.

Servizio richiesto: *Service needed:*

Solo taratura Riparazione Riparazione & Taratura Taratura SIT Altro:
 Calibration only Repair Repair & Calibration Certified Calibration Other:

Ditta:

Company:

Indirizzo:

Address:

Persona da contattare:

Technical contact person:

Telefono:

Phone n.

Modello:

Equipment model:

Numero di serie:

Serial n.

Accessori ritornati con l'apparecchiatura: **Nessuno** **Cavo(i)** **Cavo di alimentazione** **Altro:**
 Accessories returned with unit: None Cable(s) Power cable Other:

Sintomi o problemi osservati: *Observed symptoms / problems:*

Guasto: **Fisso** **Intermittente** **Sensibile a:** **Freddo** **Caldo** **Vibrazioni** **Altro**
 Failure: Continuous Intermittent *Sensitive to:* Cold Heat Vibration Other

Descrizione del guasto/condizioni di funzionamento:

Failure symptoms/special control settings description:

Se l'unità è parte di un sistema descriverne la configurazione:

If unit is part of system please list other interconnected equipment and system set up:

