



TVOC 2

Instrument User Manual V1.2

NEED HELP?

SCAN OR CLICK HERE
TO CONTACT US



Air-Met Scientific
www.airmet.com.au



Register
your instrument
online to receive your
extended Warranty.

Register your instrument online for extended warranty

Thank you for purchasing your ION Science instrument.

The standard warranty of your instrument can be extended to up to five years on PhoCheck Tiger and two years on other ION Science instruments.

To receive your extended warranty, you must register your instrument online within one month of purchase (terms and conditions apply.)

Visit ionscience.com/instrument-registration

EU Declaration of Conformity

The EU Authorised Representative of the manufacturer Ion Science limited has sole responsibility, on the date this product accompanied by this declaration is placed on the market, the product conforms to all technical and regulatory requirements of the listed directives

Authorised Representative: ISM Deutschland GmbH · Laubach 30 · D-40822 Mettmann, Germany

Product: TVOC 2

Product Description: An intrinsically safe fixed continuous monitor comprising of a photo-ionisation detector for detecting and measuring volatile organic compounds with a 4-20 mA output

Directive : ATEX Directive (2014/34/EU)
EMC Directive (2014/30/EU)

Type of protection:  II 2G Ex ia IIC T4 Gb (-20 °C ≤ Ta ≤ +50 °C)

Notified Body: SGS Fimko 0598

Certificate Number: Baseefa05ATEX0277X

Type of protection :  II 3G Ex nA IIC T4 Gc (-40 °C ≤ Ta ≤ +50 °C)

Notified Body: Ion Science Ltd Self certified EC Type Examination Certificate(s)

Certificate Number: Ionscience09849X

Standards

EN IEC 60079-0:2018	Electrical Apparatus for Potentially Explosive Atmospheres – General Requirement
EN IEC 60079-11:2018	Explosive Atmospheres - Equipment Protection by Intrinsic Safety ‘i’
EN IEC 60079-15:2010	Explosive Atmospheres - Equipment Protection by other means ‘n’
EN 61010-1:2010	Safety requirements for electrical equipment for measurement, control and laboratory use – General requirements
EN 61000-6-4:2007 (+A1)	Electromagnetic compatibility (EMC) - Part 6-4: Generic standards Emissions standard for industrial environments
EN 50270:2015	Electromagnetic compatibility. Electrical apparatus for the detection and measurement of combustible gases, toxic gases or oxygen.

Other Standards

EN ISO/IEC 9001:2015	Quality Management Systems – Requirements
EN ISO/IEC 80079-34:2020	Potentially Explosive Atmospheres – Application of Quality Systems

Name: Clemens A. Verley

Position: Chief Executive Officer



Signature:

Date: 31st December 2020

Content

EU Declaration of conformity	3
Statements	6
Responsibility for use	6
Quality assurance	6
Disposal.....	6
Legal Notice	6
Introduction to TVOC 2	8
Packing list	8
Standard TVOC 2 instrument.....	9
TVOC 2 Accessory Kit (A-900214).....	9
TVOC 2 Set-up	10
Selector Pins	10
Installation	11
Location	11
Cable and gland requirements	12
Dimensions for mounting	13
Power requirements.....	13
Initial calibration	16
Operation	17
Start-Up	17
LED's	17
Selector pins	18
Calibration mode	18
Calibration gases.....	18
Calibration routine	19
Setting the ZERO	20
Setting the span gas concentration.....	21
Setting the SPAN.....	21
Maintenance	23
Cleaning / replacing the lamp	23
Inspecting the MiniPID stack.....	24
Inspecting and cleaning the MiniPID lamp.....	24
Assembly of MiniPID electrode stack, lamp and body	27
Fuse rupture and replacement.....	27



Lamp Warranty Statement.....	28
System recommendations.....	28
Gas sample systems.....	29
Flow adapter fitting instructions	29
Instrument warranty and service.....	30
Warranty.....	30
Service	30
Contact details.....	31
Diagnostics	32
F3 error	33
F4 error	33
Technical specifications.....	35
Manual log	37

Statements

Responsibility for Use

TVOC 2 detects a large range of gases, which are potentially dangerous from both a poisoning and/or an explosive perspective. TVOC 2 has a number of selectable features allowing the detector to be used in a variety of applications. ION Science Ltd can accept no responsibility for the incorrect adjustment of features that cause harm or damage to persons or property. It is the users' responsibility to respond appropriately to the readings delivered.

Inadequate performance of the gas detection equipment described in this manual may not necessarily be self-evident and consequently equipment must be regularly inspected and maintained. ION Science recommends that personnel responsible for equipment use institute a regime of regular checks to ensure it performs within calibration limits, and that a record be maintained which logs calibration check data. The equipment should be used in accordance with this manual, and in compliance with local safety standards.

Warnings

1. Substitution of components may impair intrinsic safety and result in unsafe conditions.
2. For reasons of safety, TVOC 2 must only be operated and serviced by qualified personnel.
3. Please read and understand this user manual fully before installing, operating or servicing TVOC 2.
4. In the event of the internal supply fuse being ruptured the 4-20 mA output will not provide indication of a system failure. Therefore, we advise the TVOC 2 installation is inspected on a regular basis.

Quality Assurance

TVOC 2 instruments are manufactured by Ion Science Limited within an ISO 9001:2015 compliant quality system, which ensures that the equipment supplied to our customers has been designed and assembled reproducibly, and from traceable components.

Disposal

Dispose of TVOC 2 and its components in accordance with all local and national safety and environmental requirements. This includes the European WEEE (Waste Electrical and Electronic Equipment) directive. ION Science Ltd offers a take back service. Please contact us for more information.

Legal Notice

Whilst every attempt is made to ensure the accuracy of the information contained in this manual, Ion Science accepts no liability for errors or omissions, or any consequences deriving from the use of information contained herein. It is provided "as is" and without any representation, term, condition or warranty of any kind, either expressed or implied. To the extent permitted by law, ION Science shall not be liable to any person or entity for any loss or damage which may arise from the use of this manual. We reserve the right at any time and without any notice to remove, amend or vary any of the content which appears herein.

TVOC 2 is a fixed continuous monitor for the detection and measurement of total volatile organic compounds, which can be dangerous from both a poisoning and explosive perspective. Total VOC's are detected using PID (Photo ionisation detection) technology.

TVOC 2 has a number of user selectable features which define its operation and will be application dependent. The user can define the detection ranges or 0.01 – 10 ppm, 0.1 – 100 ppm or 1 – 1,000 ppm (Default); detection units, either ppm or mg/m³.

NOTE: TVOC 2 can be calibrated on alternative gases to Isobutylene however to ensure it remains within specification, the correct concentration for the alternative gas must be chosen.

Example: Benzene gas has a response factor of 0.5 which means only half as much concentration is required to produce the equivalent to Isobutylene.

The ideal gas / concentrations used to set the calibration SPAN are shown below: -

	Lower limit	Upper limit	
10 ppm range	8 ppm	12 ppm	Isobutylene equivalent
100 ppm range	90 ppm	110 ppm	Isobutylene equivalent
1,000 ppm range	900 ppm	1100 ppm	Isobutylene equivalent

How to calculate alternative concentration of gases for gases other than Isobutylene: -

<u>Calibration Gas</u>	<u>Ideal response for Isobutylene</u>		<u>Response factor</u>		<u>Ideal calibration gas concentration</u>
Benzene	100	x	0.5	=	50 ppm
Isoprene	100	x	0.9	=	90 ppm
Isobutylene	100	x	1.0	=	100 ppm
Carbon disulfide	100	x	1.4	=	140 ppm
Ethyl acrylate	100	x	2.3	=	230 ppm

For other gas response factors please refer to the ION Science web site or contact ION Science Ltd.

<https://www.ionscience.com/product-range/search-by-gas/>

WARNING: Ignoring these guidelines may result in calibration failure, loss of resolution or loss of range.

The default settings of TVOC 2 are:

Detection range	-	1 – 1000 ppm
Units	-	ppm

TVOC 2 gives a continuous 4-20 mA output which can be integrated into a DCS control system to give an indication of VOC levels in the operating environment.

NOTE: The 4-20 mA output must be externally powered with 8-35 V.

In addition to the 4-20 mA output TVOC 2 has an LCD display showing gas concentration and 4 colour LEDs. LED functions are as follows:

Green	- is an indicator of TVOC 2's working status
Red	- is the fault indicator
Yellow x 2	- are calibration status indicators

Please see Calibration for more information on LED status.

Introduction to TVOC

For installation requirements please refer to Installation and Technical Specification of this manual. Before attempting an installation, please fully read and understand this user manual. For hazardous area installations, refer to the TVOC 2 Intrinsically safe certificate for further details.

The TVOC 2 safety rating permits its deployment in all hazardous areas of the quoted (or less demanding) rating. For details, refer to the marking on your instrument (found on the front main label). Units are manufactured with two protection concepts applied by separate certifications. Intrinsic safety (ia) and Non-sparking (nA).

a) Intrinsic Safety (ia) permits the deployment in areas where explosive gases (of group IIA, IIB and IIC) are intermittently present (Zone 1) with an ambient temperature range of -20 to +50 °C. Intrinsically Safe installations will require the use of safety barriers and appropriate wiring.

b) Non-sparking (nA) permits deployment in areas where explosive gases (of group IIA, IIB, IIC) are unlikely, but possible (Zone 2) with ambient temp range of -40 °C to +50 °C. Non-sparking installations do not require safety barriers, however the maximum working voltage should be strictly adhered to as a matter of safety. As no safety barriers are required, there is complete flexibility on the implementation of a three-wire system.

TVOC 2 does require regular calibration on site, see the Calibration section for more information.

Packing list

All items of equipment shipped by ION Science Ltd are packed in suitable containers and enclosed in a shock absorbing filling which affords a considerable degree of protection against physical damage.

Contents should be carefully removed and checked against the packing list. Any discrepancies between the contents and the packing list must be reported to ION Science Ltd within ten days of receipt of shipment. ION Science cannot be held responsible for shortages not reported with in the period.

Standard TVOC 2 instrument

Item	Description	Qty
1.	TVOC 2 instrument	1
2.	Cable gland M20 (Ex Certified)	2
3.	Blanking plug M20 intrinsically (Ex Certified)	1
4.	TVOC 2 Safety Notices	1
5	TVOC 2 Basic Accessory Kit (A-900215)	1

TVOC 2 Accessory Kit (A-900214)

Item	Description	Qty
1.	Calibration magnet	1
2.	Calibration adaptor	1
3.	Calibration connector	1
4.	Aspirator	1
5.	Carbon filter	1
6.	Allen keys	2

(See diagram below)

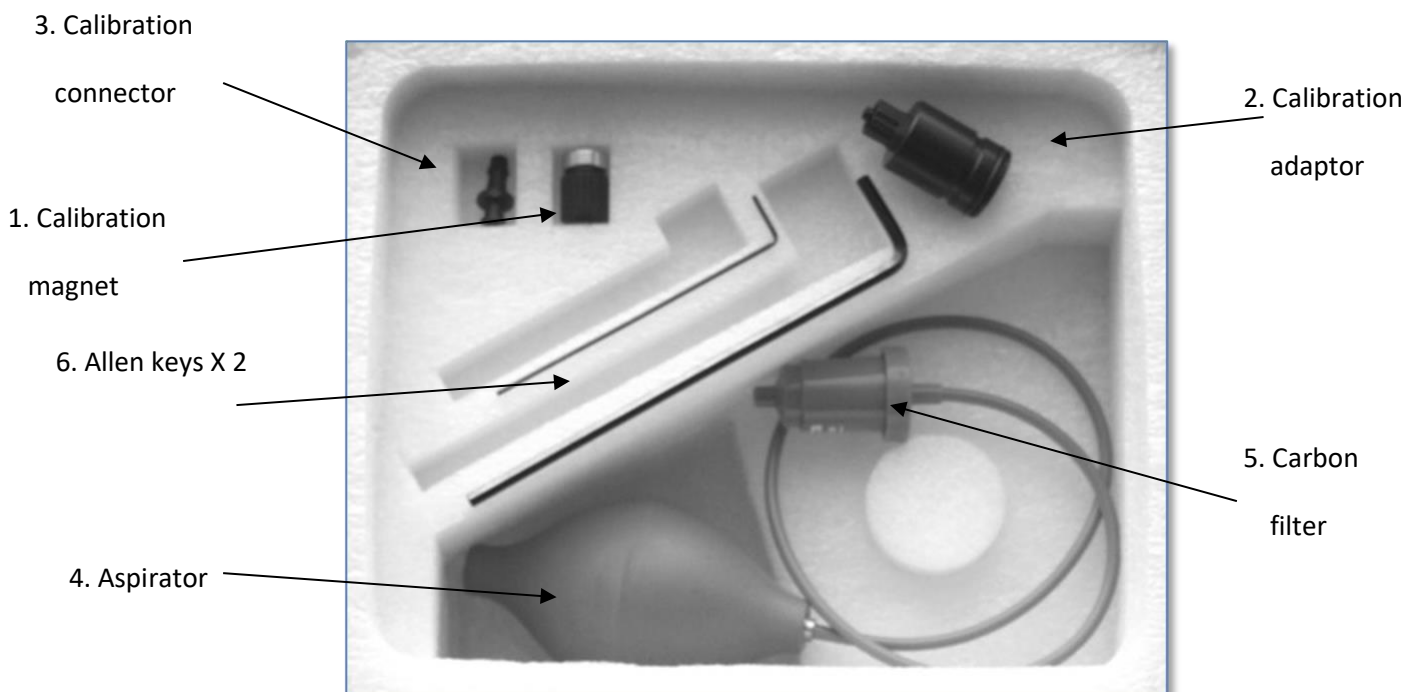

TVOC 2 Set-up

Selector Pins

TVOC 2 has a number of settings that can be selected by the user via a row of four selector pins mounted on the reverse side of the main PCB. Diagram 3 shows the location of the functional selector pins labelled - A, B, C & D.

The selector pins absence or presence determines the chosen setting.

TVOC 2 is shipped with all four of the selector pins fitted as shown in Diagram 3.

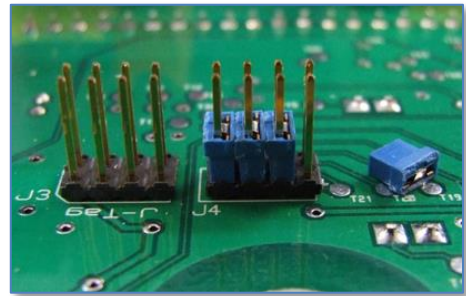

Diagram 1

Diagram 1 shows selector pin A removed.

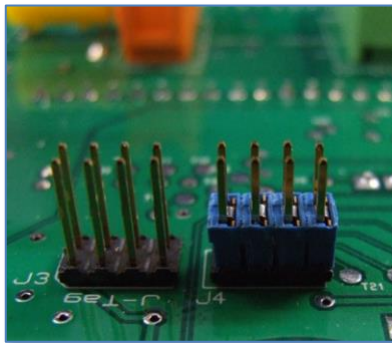

Diagram 3

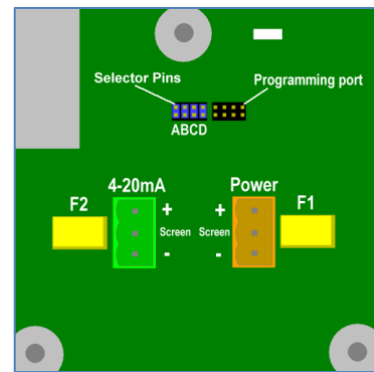

Diagram 2

The following table shows the selector pin combinations and the corresponding function.

✓ = Selector pin fitted

✗ = Selector pin removed

Selector pin				Range	Displayed units
A	B	C	D		
✓	✓	✓	✓	1000	ppm (Default)
✓	✓	✗	✓	100	ppm
✓	✗	✓	✓	10	ppm
✓	✓	✓	✗	2280	mg/m ³
✓	✓	✗	✗	228	mg/m ³
✓	✗	✓	✗	22.8	mg/m ³

Selector pin 'B' and 'C' selects the ranges - 10 ppm, 100 ppm or 1000 ppm

Selector pin 'D' selects the units	-	"ppm" or "mg/m ³ "
Selector pin 'A'	-	Fault output range

NOTE: During an Alarm condition (F1 or F2) the output will drop to either 3.5 mA or 2.0 mA.

Jumper 'A' fitted: 3.5 mA during an alarm condition.

Jumper 'A' removed: 2.0 mA during an alarm condition.

As default, the TVOC 2 has a 100 ppm factory calibration.

NOTE:

- TVOC 2 is shipped with ALL selector pins fitted as standard
- TVOC 2 only reads the selector pin settings when power is connected.
- Always ensure power is disconnected from TVOC 2 before changing setting or carrying out maintenance.
- Never place selector pins on the programming port connector.
- Ensure static build up is discharged before touching components.
- If the selector pin setting is not recognized, then error F4 will occur. To recover switch the instrument off perform the correct jumper selection and switch the instrument back on.

Installation

Location

There are many variables involved in defining the optimum location for a gas detector. Obvious though it may sound, the most important rules are:

- A detector will not detect gas unless gas actually reaches the detector.
- TVOC 2 should be mounted in the location most likely to detect gas.
- TVOC 2 must be mounted vertically with the sensor underneath the case. This avoids water, dust and debris blocking the access to the detector cell.
- If possible, mount TVOC 2 near the ceiling to target VOC gases that are lighter than air or just above floor level to detect VOC gases that are heavier than air.
- Mount TVOC 2 in an area that has good air circulation. Restricting natural air current may result in delayed detection.
- Never mount TVOC 2 in direct sunlight or over a heat source such as a radiator. This may cause the unit to exceed its certified working temperature range.
- Do not mount TVOC 2 in areas likely to flood.
- Mount TVOC 2 units in locations that are easily accessible for servicing.
- Percentage variations in the composition of air (78 % Nitrogen, 21 % Oxygen and 1 % Argon) may affect the detected signal.

NOTE: Please refer to the technical specifications of the instrument in this manual before beginning a TVOC 2 installation.

Cable and gland Requirements

The screw terminal sockets for connecting wires in the TVOC 2 accept wires of 0.5 mm² to 2.5 mm² Cross-Sectional Area (CSA)

Screened cables for both power and signal out are necessary to achieve EMC compliance. Cable screens must be terminated at both ends for them to be effective in achieving electromagnetic compatibility (EMC). The screens should be terminated to the TVOC 2 enclosure using EMC compatible cable glands. It is important for an EMC compatible gland to make electrical contact to the enclosure. This is usually done using a serrated washer or EMC lock nut that bites through the paint making electrical contact. EMC lock nuts have been provided. These locknuts are orientation specific. The points should be facing against the case in order to cut through the paint during tightening.

Two M20 cable glands and one blanking plug have been supplied as standard to ease installation in most circumstances. These parts will not be appropriate for all applications, they should be used at the discretion of the installation engineer. It is recommended that the manufacturer's instructions are followed for the gland and blanking plug installation. The M20 blanking plug has been included to enable installations using a single cable entry (for example a three-wire system) to be implemented.

While ION Science cannot recommend the cable gland suitable for every application, the following information may be useful to the installation engineer for the selection of the appropriate type:

- For intrinsically safe operation using safety barriers, the only requirements on the cable glands are that they are better than IP20 rated. This may seem extraordinary however, where the power is safely limited to the TVOC 2 it is intrinsically safe so does not rely on the prevention of dirt or moisture into the enclosure.
- For safe operation in Zone 2 without safety barriers, cable glands must be ATEX or IECEx rated (Ex e, Ex n or Ex d) and at least IP54.

Installation of the TVOC 2 depends on preferences of the installer, intrinsically safe operating legislation and the application.

ION Science suggests connecting the screens from cables via a gland as shown on the diagrams and under Installation Section of this manual. However, there might be technical circumstances where connection to the PCB is necessary.

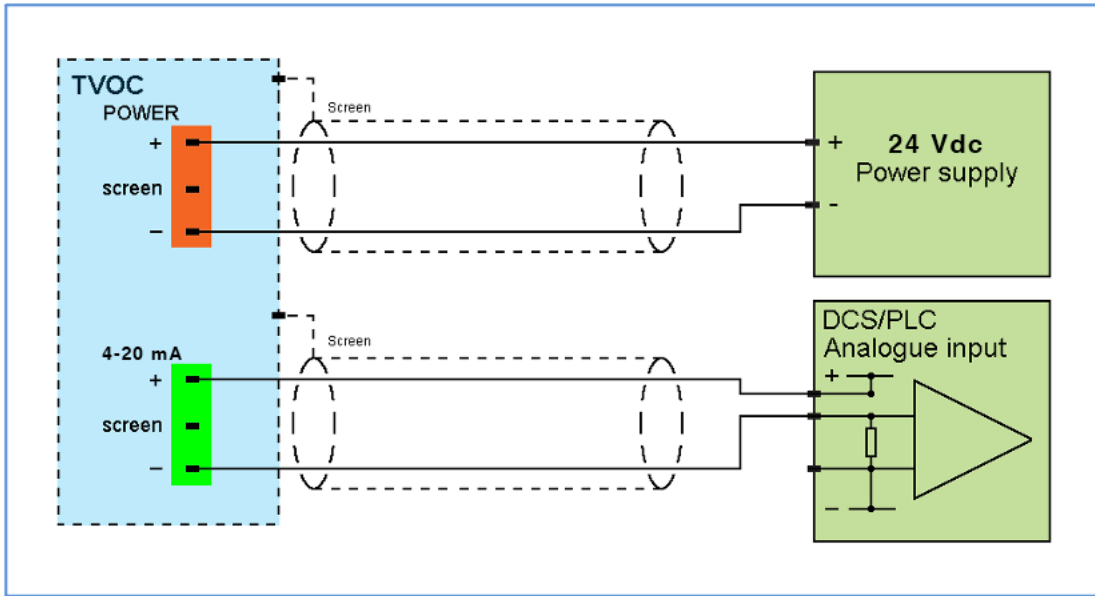

Diagram 5 - 4 Wire System (Non-IS)

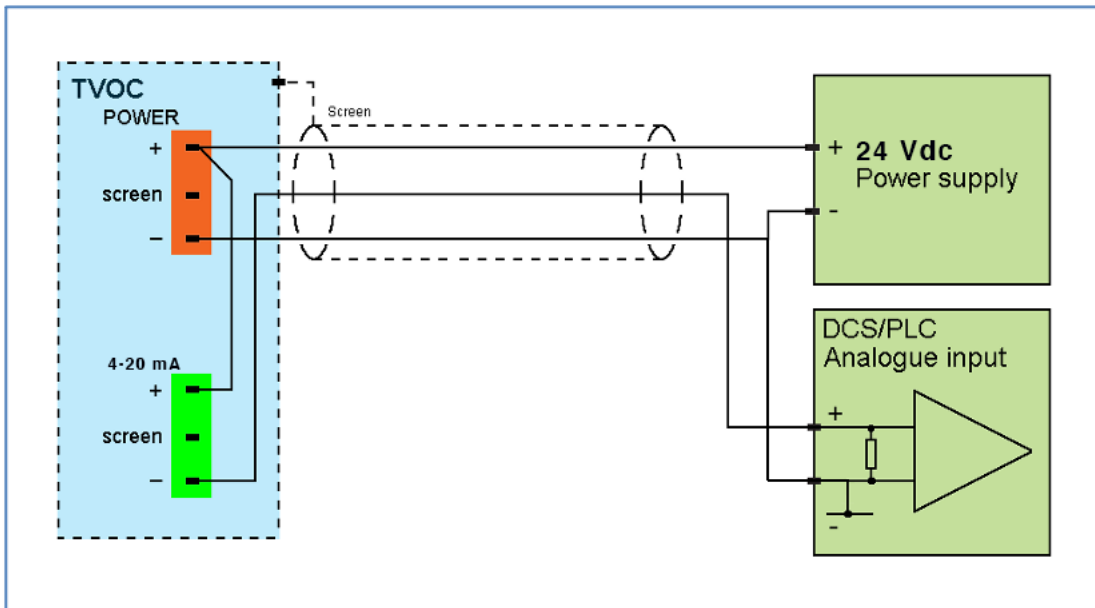

Diagram 6 - 3 Wire System (Non-IS)

WARNING:

The label on the enclosure details both Zone 1 and Zone 2 certifications. The appropriate section of the Intrinsically Safe label should be covered up or blocked out to reflect the type of installation. For Non-intrinsically Safe applications the label should be covered completely. For Zone 2 applications without safety barriers the ia certification details should be blanked out. For Zone 1 or Zone 2 IS applications with safety barriers the nA certification details should be covered. This will prevent safety discrepancies in the future should the equipment be moved or the site be re-defined as a hazardous area.

Entry parameters for Zone 2 only, nA (non-sparking) areas:

Input (Power) $U_i = 24\text{ V}$

Output (4-20 mA) $U_i = 35\text{ V}$

For information only: please see Intrinsically Safe operation certificate before installation.

The wiring of Zone 2 systems is identical to the wiring showing for non-intrinsically Safe applications. The only difference is the requirement to ensure that the power supply used provides 24 V or less in normal operation.

Entry parameters for Intrinsically Safe, Zone 1 or Zone 2 installations:

Input (Power) $U_i = 18\text{ V}$ $I_i = 800\text{ mA}$ $P_i = 1.2\text{ W}$ $C_i = 0\mu\text{F}$ $L_i = 0\text{mH}$

Output (4-20 mA) $U_i = 30\text{ V}$ $I_i = 200\text{ mA}$ $P_i = 1.2\text{ W}$ $C_i = 0\mu\text{F}$ $L_i = 0\text{mH}$

For information only, please see Intrinsically Safe certificate before installation.

ION Science Ltd suggest using Zener barriers for IS approved applications. Use competent installation engineers and ask them for installation and application advice.

WARNING: Intrinsically Safe (IS) and Zone 2 applications

- Units should not be powered using non-IS power supplies prior to installation in an IS application.
- If non-IS power is supplied the unit will require inspection by ION Science Ltd or an ION Science Approved Service Centre prior to installation in an IS application.
- TVOC 2 fuses may not be replaced in the field.
- If a fuse is blown TVOC 2 will require inspection by ION Science Ltd or an ION Science Approved Service Centre before it is used in an IS application.

WARNING: – Potential Electrostatic Charge Hazard

The unit should be installed and maintained to avoid the build-up of electrostatic charge on the front label:

Do not install TVOC or TVOC 2 where they will be brushed by fabric.

Clean only with a damp cloth.

WARNING: – Cable glands or blanking plugs must be fitted.

WARNING: - DO NOT REMOVE OR REPLACE FUSE WHEN ENERGIZED.

CAUTION: – The unit must be installed with the opening in the sensor housing pointing downwards.

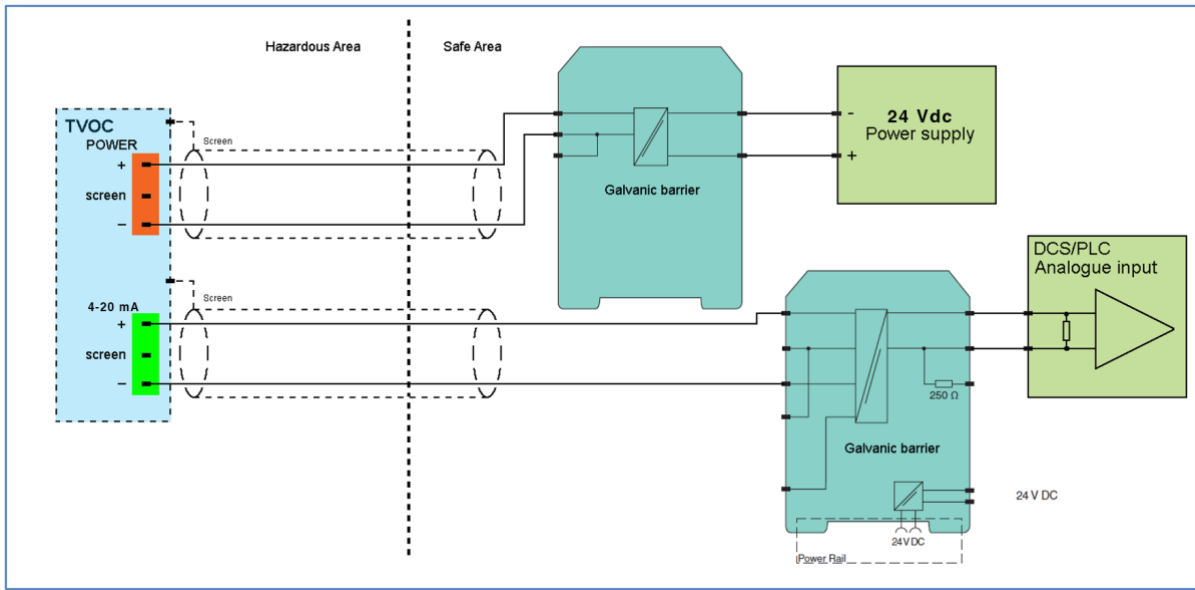

Diagram 7 - 4-wire Control equipment sensing 4 – 20 mA on return line

NOTE: For intrinsically safe installations, the enclosure may be opened while the system is live, provided the work is undertaken by competent personal and suitable safety precautions are taken.

Initial Calibration

TVOC 2 is calibrated at ION Science before dispatch using 100 ppm Isobutylene. However, if you wish to calibrate your TVOC 2 after installation, ION Science recommends the unit is left to run on its chosen settings (see 'TVOC 2 Set-up Section') for 24 hours before an initial calibration is carried out, to allow the instrument to stabilise.

NOTE: If the 0-10 ppm range is selected, the TVOC 2 will require calibration using 10 ppm Isobutylene before use (See the calibration section of this manual).

Operation

Start-Up

After electrical power is connected, TVOC 2 runs through a 'Start-up' routine, which lasts for approximately 1 minute. During this 'Start-up' routine, TVOC 2 demonstrates the following characteristics:

- The LCD screen displays the software version number
- The green LED flashes
- The 4-20 mA output is set to 4 mA (0.0 ppm)

Update Rate

TVOC 2 has a fixed output update rate of one second.

LED's

Diagram 10 shows the location and function of the four LED indicators

The green indicates TVOC 2's working status:

ON - Indicates the PID lamp is OFF

Flashing - Indicates the PID lamp is ON

A red indicates fault status:

ON - Indicates TVOC 2 cannot function correctly. The 4-20 mA output drops to 3.5 mA. URGENT attention is required.

Flashing - Indicates the TVOC 2 cannot function but a reading is being attempted

A yellow Zero LED indicates during normal operation

ON - Last calibration zero level was outside expected limits

(The instrument will operate normally with the previous calibration)

A yellow Span LED indicates during normal operation

ON - Last calibration Span level was outside expected limits

(The instrument will operate normally with the previous calibration)

Please see Calibration section for YELLOW LED states.

Selector Pins

TVOC 2 has a range of options that are selected via the selector pins on the back of the main PCB (please see the 'TVOC 2 Set-up' Section). The options are shown below with the defaults highlighted in bold:

1-1000 ppm	or	0.01 – 10 ppm or 0.1 – 100 ppm
ppm units	or	mg/m3 units

Calibration Mode

TVOC 2 calibration mode can be accessed using the calibration magnet supplied in the TVOC 2 Accessory Kit (Part number: A-900214).

To enter calibration, place the magnet over the ION Science logo until the state changes i.e. an LED illuminates and/or the display changes. (see Diagram 8)

Ensure the magnet is withdrawn away from the magnetic switch by at least 4 cm once a change has occurred.

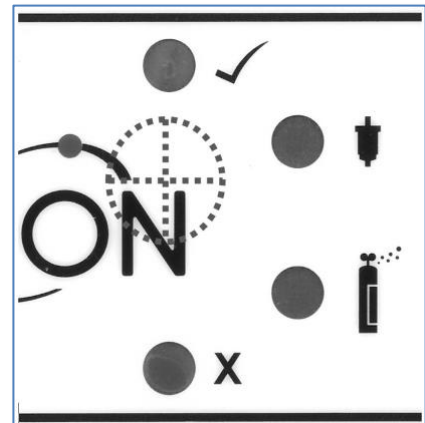

Diagram 8

Calibration Gases

TVOC 2 has three ranges that can be selected, however the 0-10 ppm range requires the instrument is calibrated by the user before it can be used. The 0-100 ppm and the 0-1000 ppm ranges can initially run using the Factory calibration.

If the 0-10 ppm range is selected TVOC 2 will display the following screen to indicate that a calibration is required before it can be used. (See diagram 9)



Diagram 9

Follow the calibration instructions before use.

NOTE: The 0-10 ppm range is more sensitive and more susceptible to environmental and system tolerances the instrument must be calibrated before use.

Calibration Routine

ION Science recommends calibrating TVOC 2 after any maintenance or lamp cleaning is carried out and on a 3 monthly basis to ensure TVOC 2 is working to specification.

NOTE: Please read this entire calibration procedure before attempting a calibration.

TVOC 2 calibration is undertaken in three steps:

- | | |
|-----------------------------------------------|--------------------------------------------------------------|
| 1. Setting the ZERO | (Using clean gas via carbon filter) |
| 2. Setting the span gas concentration ranges) | (1 – 200 ppm Isobutylene on 0-100 ppm and 0-1000 ppm ranges) |
| | (0.1 – 20.0 ppm Isobutylene on the 0-10 ppm range) |
| 3. Setting the SPAN | (Using the SPAN gas) |

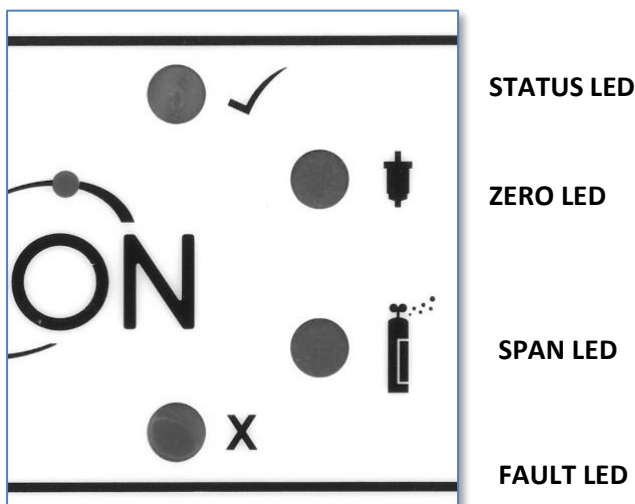
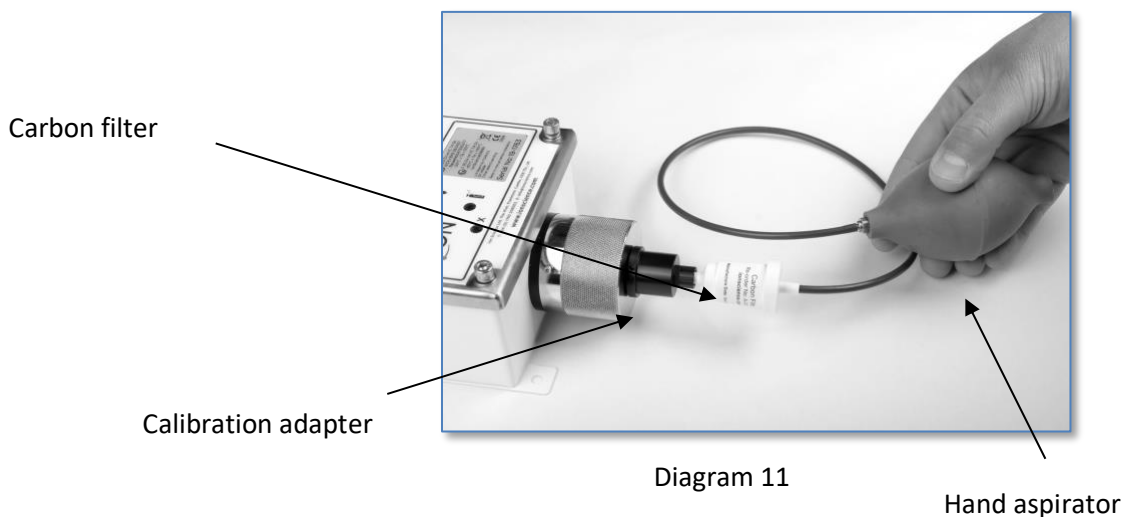

Diagram 10 shows location of LEDs

Diagram 10

Setting the ZERO

- 1 – Place the calibration magnet over the ION Science logo to enter calibration mode. *The 'ZERO LED' will illuminate and the 'STATUS LED' will extinguish.*
- 2 – Remove the calibration magnet
- 3 – Insert the calibration adaptor into the sensor cap, attach the carbon filter to the calibration adaptor. The carbon filter should be attached to the hand aspirator. (See Diagram 11)
- 4 – Again place the calibration magnet over the logo.
- 5 – Slowly and repeatedly squeeze the hand aspirator to push clean air through the carbon filter and past the PID sensor. The 'ZERO LED' will stop flashing after approximately 30 seconds.
- 6 – Now remove the equipment except for the calibration adaptor.



The 'ZERO LED' will flash, during this stage TVOC 2 displays a direct millivolt (mV) output from the PID sensor. The zero mV reading must fall below 100 mV.

An acceptable ZERO calibration level will result in the illumination of the 'STATUS LED'.

An unacceptable ZERO calibration level will result in the illumination of the 'FAULT LED'. Should this occur the TVOC 2 will not proceed to the gas tolerance setting and return to normal operation the previous calibration levels will be used. The yellow 'ZERO LED' will be illuminated to indicate the failure to set a zero-calibration level.

Setting Span Gas Concentration

- 1 – Place the calibration magnet over the logo – *The green 'STATUS LED' will be extinguished, and the numeric display will start to flash.*



Diagram 11

- 2 – If the 0-10ppm range is selected you will be able to adjust between 0.1 ppm and 20ppm, for both the 100 ppm and 1000 ppm ranges a concentration of between 1 and 200 ppm can be selected. Leaving the magnet in position will cause the displayed number to cycle through the concentration, remove the magnet when the displayed value matches that stated on the calibration gas bottle. Should you miss the desired reading quickly reapply the magnet to continue scrolling through the numbers and remove the magnet at the desired figure.

The selected number will be recorded 5 seconds after the removal of the magnet when the display stops flashing. The display will initially show 100, should this be the desired figure remove the magnet straight away. (See Diagram 12)

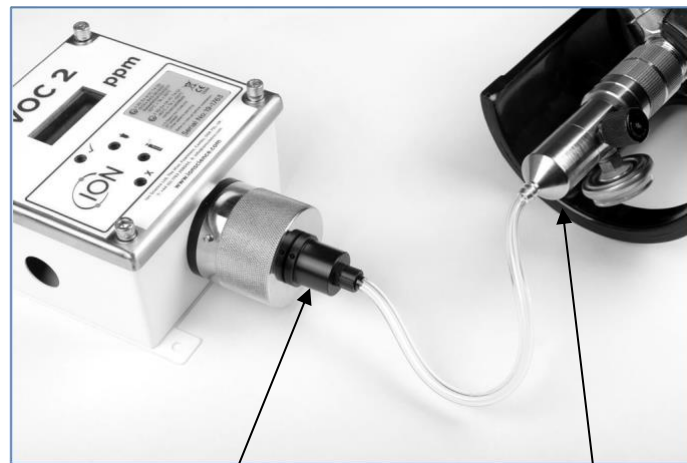

Calibration adaptor

SPAN gas

Diagram 12

Setting the SPAN

- 1 – Connect the SPAN gas to the calibration connector then the connector to the adaptor. (See Diagram 13)

Switch on the gas supply, wait for the numbers on the screen until they are going up in 2s, then place the magnet over the logo.

The yellow 'SPAN LED' will flash and TVOC 2 will display the direct millivolt (mV) output from the PID sensor. Now remove the magnet. The Span mV reading should be more than 150 mV if using 100 ppm isobutylene. The span mV reading should be at least 500 mV if using 1000 ppm isobutylene.

- 2 – The 'SPAN LED' will stop flashing after approximately 2 minutes, 30 seconds.
- 3- Now place the magnet over the logo to confirm calibration.
- 4- Leave gas connected.
- 5- The instrument will now go through its first cycle (the green LED will be flashing). The LCD should display concentration of gas used during calibration eg 100 ppm.

NOTE: If the fault LED is flashing at the end of a cycle, another calibration is required.

Calibration

An acceptable SPAN calibration level will result in the illumination of the green 'STATUS LED'.

An unacceptable SPAN calibration level will result in the illumination of the red 'FAULT LED'. Should this occur the previous calibration levels will be used when the instrument returns to normal operation. The Yellow 'SPAN LED' will be illuminated to indicate the failure to calibrate the span.

NOTE: During the span measurement process the mV reading of the span must be greater than the zero level to pass the SPAN calibration stage.

The green 'STATUS LED' will begin flashing as TVOC 2 starts.

NOTES:

- Always check the accuracy of your calibration by checking readings from TVOC when it is running normally using the ZERO filter and SPAN gas.
- Accuracy of calibration is the responsibility of the person carrying out the calibration. If in doubt seek advice.
- TVOC must be calibrated after lamp/cell cleaning or general maintenance.

Causes of contamination and error in signal:

- Changes in air pressure when detecting ppm concentration
- Variation in oxygen, argon beyond ambient levels.
- Variation in ambient moisture content

Bump Test

To perform a bump test, apply gas to the instrument. Wait at least 2 minutes 30 seconds with the gas applied (or until instrument readings are stabilised) to take a reading.

NOTE: If the TVOC 2 isn't reading similar to the gas concentration applied, the instrument will need to be re-calibrated.

Maintenance

Cleaning / Replacing the Lamp

TVOC 2 has been designed to ensure servicing is quick and easy:

1. Before servicing TVOC 2, disconnect the electrical power supply.
2. Remove the locking screw from the metal sensor cap using the Allen key supplied in the TVOC 2 Accessory Kit - part number A-900214, (see Diagram 14)

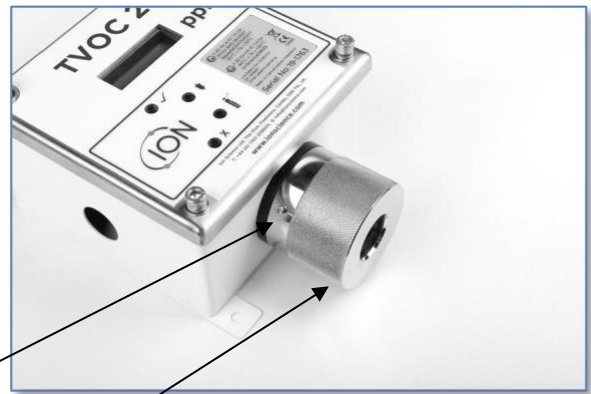

Locking screw

Diagram 13

Sensor cap

WARNING:

Failing to remove the locking screw before unscrewing the *sensor cap* will damage the sensor holder.

3. Unscrew the *sensor cap* to access the PID sensor.
4. Remove the PID Sensor by withdrawing it from the *sensor housing*. Only light force is required (see Diagram 15)

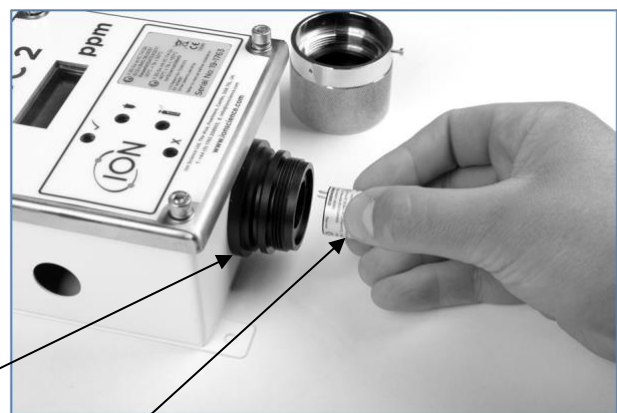

Sensor housing

Diagram 14

PID sensor

WARNING:

Do not twist the PID Sensor while it is within the *sensor housing*.

5. The *electrode stack* and *PID lamp* can then be removed using the Electrode Stack Removal tool (See diagram 16)

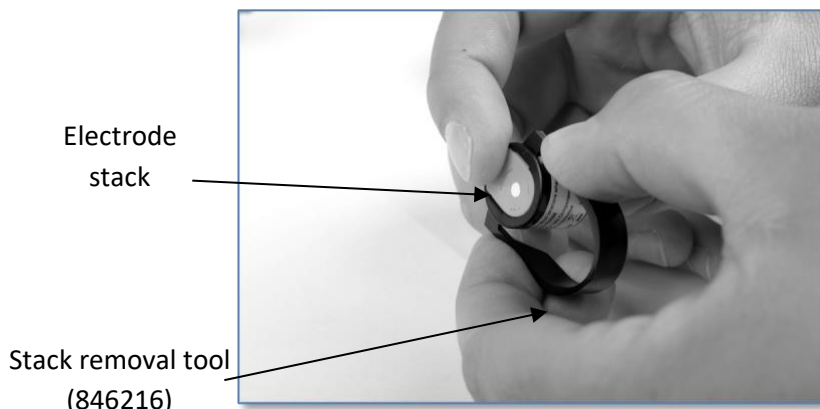

Diagram 15

WARNING: Only use the electrode stack removal tool. Any other tools (for example screwdrivers) may damage your MiniPID body and will invalidate your warranty.

1. Locate electrode stack removal tool in the side slots of the MiniPID and squeeze together until electrode stack and lamp are released.
2. Carefully lift the MiniPID 2 body away from the electrode stack and lamp.
3. Occasionally the lamp may be temporarily lodged in the cell and will need to be freed carefully with tweezers. Occasionally the small spring behind the lamp will come out when the lamp is removed from the sensor. Simply replace it into the sensor house.

Inspecting the MiniPID Stack

On removal of the electrode stack, carefully inspect the underside. The visible electrodes should be shiny and metallic.

NOTE: If there are any signs of corrosion or water ingress the stack should be replaced (A-846496).

Inspecting and Cleaning the MiniPID Lamp

Inspection of the MiniPID lamp, as shown in the Diagram 17, may reveal a fine film of contamination on the lamp window. However, it should be noted that window contamination is frequently not visible.

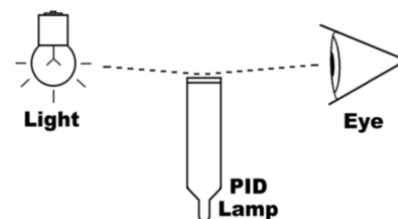

NOTE: Black or metallic deposits on the interior face of the lamp cannot be removed. If the deposits are extensive, the lamp must be replaced.

Diagram 16

To clean the lamp, use of MiniPID lamp cleaning kit A-31063. Validity of lamp warranty is compromised if lamp cleaning maintenance is not followed and lamp has obvious fouling/contamination.

- i. Wash hands, or wear gloves. Never touch the lamp window, even with gloves. The lamp body may be touched with clean fingers.
- ii. Open the container of alumina polishing compound.
- iii. With a clean cotton bud, collect a small amount of the powder.
- iv. Use a cotton bud to polish the PID lamp window. Use a circular action, applying light pressure to clean the lamp window. (see Diagram 18)



Diagram 17

NOTE: Do not touch the lamp window with fingers.

- v. Continue polishing until an audible “squeaking” is made by the cotton bud moving over the window surface. Usually this requires 15 to 30 seconds polishing.
- vi. Remove the residual powder from the lamp window with a clean cotton bud. Care must be taken not to touch the tips of cotton buds that are to be used to clean the lamps. Ensure the lamp is completely dry and all detritus is removed before refitting.
- vii. Re-assemble the sensor lamp, stack and cell as described below ‘assembly of MiniPID electrode stack, lamp and body’, and reinstall sensor in the instrument.
- viii. Bump test the sensor. If the responsivity has recovered, then recalibrate the instrument. If not, replace the lamp.

CAUTION: The lamp cleaning kit contains alumina (CAS Number 1344-28-1) as a very fine powder. Cleaning should be undertaken in a well-ventilated area. A full material safety data sheet MSDS is available on request from ION Science Ltd.

Key safety issues are identified below:

Handling:

- Do not breathe in the powder. Avoid contact with skin, eyes and clothing
- Wear suitable protective clothing
- Follow industrial hygiene practices: Wash face and hands thoroughly with soap and water after use and before eating, drinking, smoking or applying cosmetics.
- The powder carries a TVL(TWA) limit of 10 mg/m³

Hazard Identification:

- May cause irritation of respiratory tract and eyes

Storage:

- Keep container closed to prevent water adsorption and contamination.

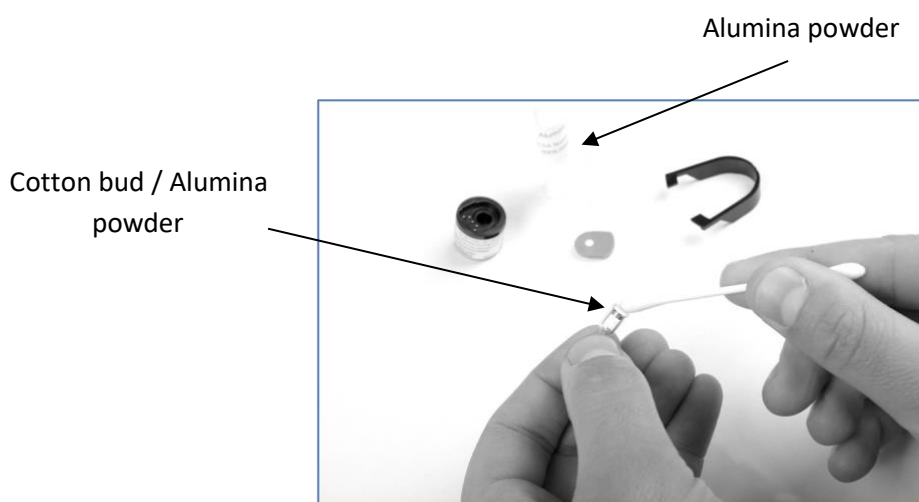

NOTE: Contamination of the Lamp window can considerably reduce the detection capability of the PID cell, even when the contamination is not visible.

Diagram 18

Cleaning of the lamp should be carried out on a regular basis depending on the duty cycle of the *PID lamp* and the environment. The humidity of the air and contaminants may affect the time required between servicing.

Assembly of MiniPID electrode stack, lamp and body

- Lay the electrode stack front face down on a clean, flat surface and then screw the lamp down into the O- ring until it firmly abuts against the front electrode face.
- Place the PID body carefully down over the lamp-stack sub-assembly so as not to disturb its seating within the electrode stack. Then push the body firmly onto the face down electrode stack so that both wings engage with the PID body.
- Inspect the sensor to confirm that both wings of the electrode stack have engaged with the PID body.
- Refit the PID sensor into TVOC 2.



Electrode stack at
12 o'clock position

Diagram 19

Ensure that the stack is at a 12 o'clock position before inserting the sensor. It should insert into the connectors easily, if significant resistance is felt, remove and check alignment before re-inserting. (See Diagram 20 above)

WARNING:

Do not assemble using a damaged lamp as this may rupture the stack's lamp O-ring seal.

Irreparable damage will be caused by forcing the PID into the *sensor housing* if not correctly aligned.

NOTE: Always calibrate TVOC 2 after servicing is carried out.

Fuse Rupture and Replacement

TVOC 2 has a 125 mA BASEEFA certified fuses to provide intrinsically safe protection when the unit is installed in hazardous areas.

A fuse may rupture for example due to over voltage or a current surge, if this is the case replacement is different depending upon the application being intrinsically safe (IS) or not.

For IS or Zone 2 applications the unit must be inspected and have the fuse replaced by ION Science Ltd or an Ion Science Approved Service Centre. The intrinsically safe rating is not maintained if the fuse is simply replaced.

For non-IS applications the fuse may be replaced by an equivalent rated fuse and operation tested by qualified engineering personnel.

Lamp Warranty Statement

NOTE: The standard warranty period for a 10.6 PID lamp is one year.

System Recommendations

TVOC 2 is generally used to measure gas concentrations in the ambient atmosphere. The sensor is open to the atmosphere and any gas that diffuses or moves under convection into the locality of the TVOC 2 sensor will be detected. Generally, the ambient environment in which TVOC 2 is located is readily accessed, but there are applications listed below that require special consideration.

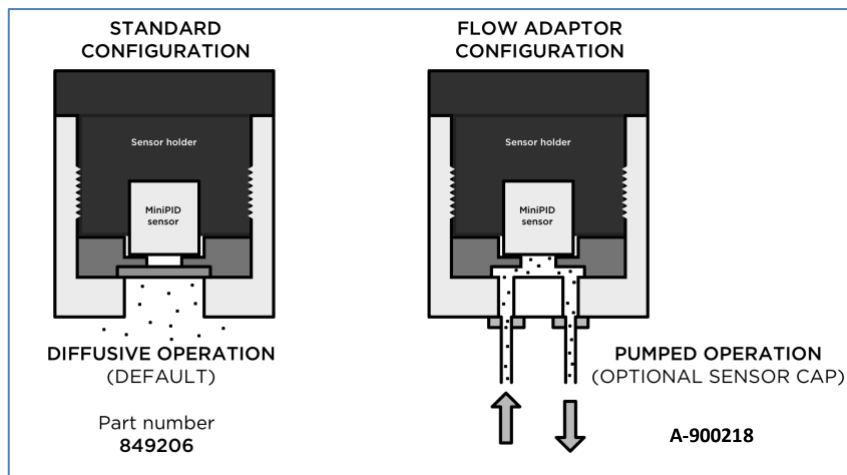
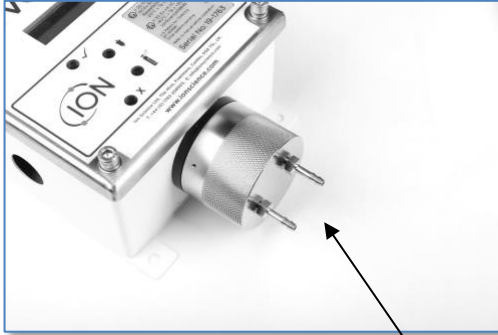

Diagram 20

Gas Sample Systems

It is sometimes necessary to pump or draw a gas sample past the TVOC 2. For this a “Flow Adaptor can be fitted. The flow adaptor has an inlet and an outlet port so that gas may be pushed or drawn across the sensor. (See Diagram 21 above)



A-900218



TVOC 2 Flow Adaptor
(A-900218)

NOTE: The Flow Adaptors for TVOC and TVOC 2 are different parts.

Flow adapter fitting instructions

Replace the metal cap with the flow adapter re-using the plastic seal disk with its O-rings. The light guard is not required.

The flow adapter cap has M5 threaded holes for use with standard pipe fittings.

For a gas sample system, we have the following recommendations:

1. Where possible, use the Flow Adaptor that is sold by ISL. This has an integral O-ring to seal the sensor housing and ports for connection of inlet and outlet sample tubes. Please refer to spare parts section for part number.
2. The pressure difference of a pumped system relative to atmosphere should be minimised to avoid the effects of gas law.
3. The maximum pressure that can be applied to the TVOC 2 sensor housing is 300 mbar. However, this is not a recommended working pressure. Ideally working pressure should be +/- 30 mbar relative to ambient pressure.
4. In line flow restrictions must be minimized. Flow restrictions cause differential pressures which can directly affect the TVOC 2 reading. If flow restrictions are unavoidable the flow rate should be lowered to minimize the pressure effects, this however will increase the response time.
5. A flow between 250 and 500 ml/min is recommended for calibration. This will ensure a full response to applied gas in a sensible time.
6. The working flow should be very similar to that use to calibrate the instrument or errors in output will occur (see point 2).
7. The response time of the system is defined by the sensor response rate and sample flow rate will in combination with the tube length and diameter as well as any dead volumes.

Instrument Warranty and Service

Warranty

Standard Warranty can be extended to up to 2 years on the TVOC 2 when registering your instrument via our website: ionscience.com/instrument-registration

To receive your Extended Warranty, you need to register within one month of purchase (Terms and Conditions apply). You will then receive a confirmation email that your Extended Warranty Period has been activated and processed.

Full details, along with a copy of our Warranty Statement can be found by visiting: ionscience.com/instrument-registration

Service

ION Science is pleased to offer a number of service options on our TVOC 2 product range that allow you to choose the instrument cover that best suits your needs.

At ION Science we recommend that all of our gas detection instruments be returned for service and factory calibration once every 12 months.

Contact ION Science or your local distributor for service options in your area.

ION Contact Details**ION Science Ltd – UK/Head Office**

Tel: +44 (0)1763 208 503

Web: www.ionscience.com | Email: info@ionscience.com**ISM ION Science Messtechnik – Germany Office**

Tel: +49 (0) 2104 1448-0

Web: <https://www.ism-d.de/en/> | Email: sales@ism-d.de**ION Science India - India Office**

Tel: +914048536129

Web: www.ionscience.com/in | Email: kschhari@ionscience.com**ION Science Inc – USA Office**

Tel: +1 877 864 7710

Web: <https://ionscience.com/usa/> | Email: info@ionscienceusa.com**ION Science Italy - Italy Office**

Tel: +39 051 0561850

Web: www.ionscience.com/it | Email: info@ionscience.it**ION Science China - China Office**

Tel: +86 21 52545988

Web: www.ionscience.com/cn | Email: info@ionscience.cn

Diagnostics

Below are two conditions your TVOC 2 can be in when it is working correctly:

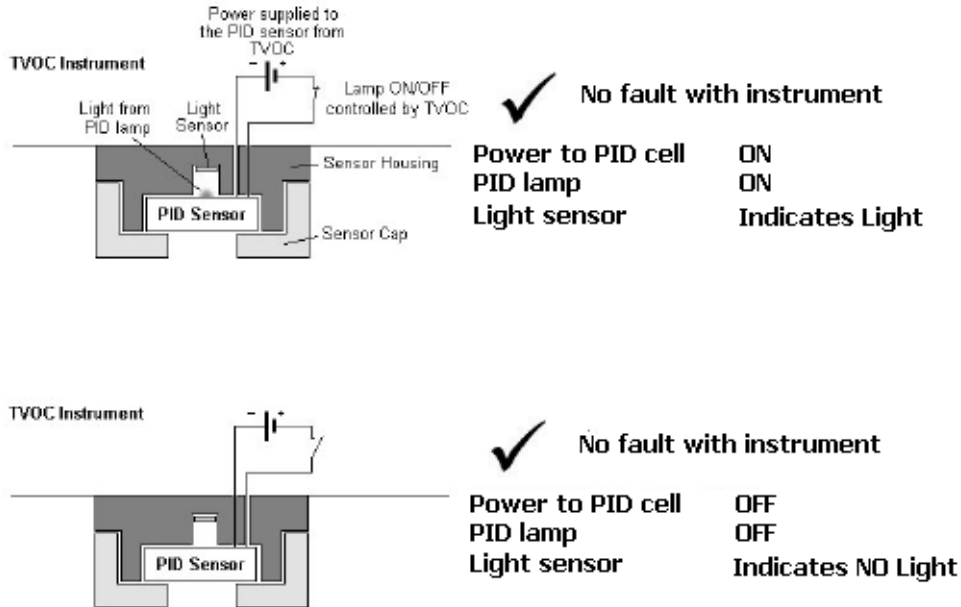

Diagram 22

The conditions shown below are of the instrument in an error state with potential checks/cures for these faults:

F1 Error

If an F1 error occurs when the instrument is first switched on there may not be an issue. The instrument needs to be left on for a few cycles to see if the lamp strikes on its own. If an F1 error is still on screen after 5 minutes, look at the information below.

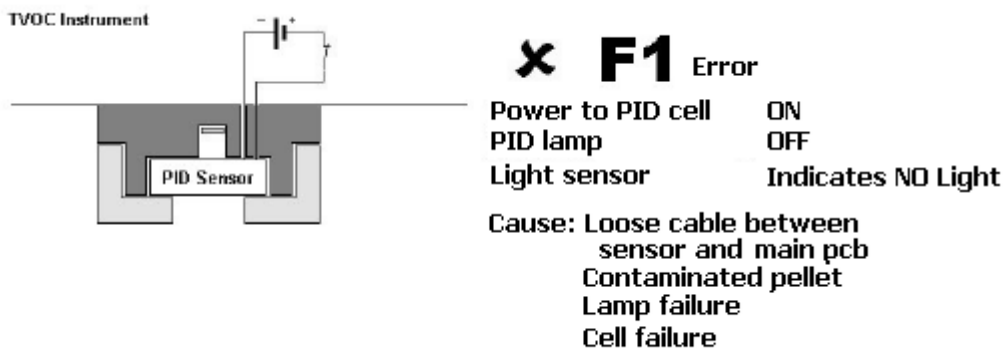

Diagram 23

If the F1 error persists for more than 5 minutes, firstly check the red cable between the sensor PCB and the main PCB is securely connected.

If the F1 diagnostic persists, replace the sensor electrode stack, part number A-846496, re-power the instrument and wait 5 minutes. If the F1 error continues, replace the sensor lamp, part number A-846656. Electrode stack and lamp spares are identified in the spare parts section below.

If the instrument continues to exhibit the F1 failure after replacement of parts, please contact your ION Science distributor.

F3 Error

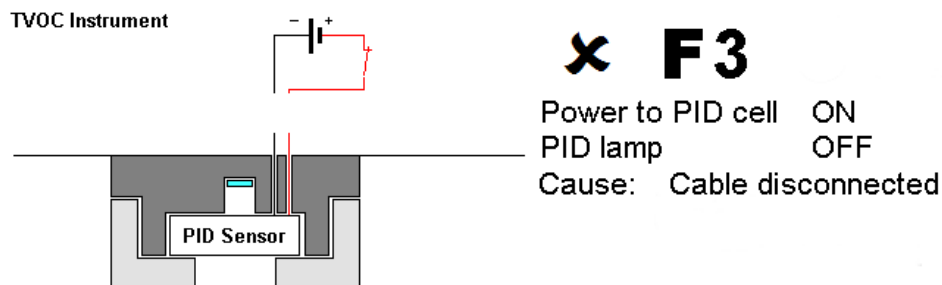

Diagram 24

The F3 error occurs when the sensor is disconnected from the power supply. If an F3 error occurs, then check the red cable is properly connected to the main PCB. If not push it fully home.

F4 Error

The F4 error occurs when an incorrect selector pin setting is used, see TVOC 2 Set - Up. Set a valid selector pin configuration and restart the unit.

Spare Parts

Part	Description	Part Number
TVOC 2 Accessory Kit	Calibration magnet, Calibration adaptor, Calibration connector, Zero gas aspirator, Carbon filter, 2 x Allen keys	A-900214
Flow adaptor (TVOC 2 only)	Replaces the standard Sensor Cap	900209
PID Lamp cleaning kit	Alumina powder and cotton buds	A-31063
Span Gas kit (100 ppm)	100ppm Isobutylene (103Litres) and Flow Regulator in a carry case	A-845213
Span Gas kit (10 ppm)	10ppm Isobutylene (103Litres) and flow Regulator in a carry case	849230
PID Sensor	Replacement PID Sensor	MP6SDL6XU2
Carbon Filter	User for ZERO span	A-31057
Calibration Magnet	User to step through calibration	A-849219
Electrode Stack	Replacement MiniPID Orange Electrode stack	A-846496
Electrode Stack Removal Tool	Used to remove the electrode stack from the MiniPID	846216
PID Lamp	Replacement MiniPID Lamp	LA4SFL3.2
O-Ring for Sensor Light	Fits to outside of Seal Disc, seals to housing	5/OV-11
Guard		
O-Ring for MiniPID Gas Port	Fits between MiniPID and the Seal Disc	5/00-108
Calibration Adaptor	For connecting to the standard cap for calibration	A-849209

Technical Specifications

PID Sensor	ION Science MiniPID 2	
Lamp type	10.6 eV (Krypton)	
TVOC 2 enclosure ingress protection	IP65	
Sensor ingress protection	IP54	
Ranges	0 – 10 ppm / 0 – 22.8 mg/m ³ (0.01 resolution)	
	0 – 100 ppm / 0 – 228 mg/m ³ (0.1 resolution)	
	0 – 1,000 ppm / 0 – 2280 mg/m ³ (1.0 resolution)	
Non-IS applications:	Input power	5 – 28 Vdc. 130 mA (0.5 mm ² to 2.5 mm ² CSA)
	4 – 20 mA	8 – 35 Vdc. 22 mA (0.5 mm ² to 2.5 mm ² CSA) 4-20mA loop must be externally powered

Zone 1 or Zone 2 Intrinsic Safe installation:

Approval Marking	II 2G Ex ia IIC T4 Gb (-20 °C ≤ Ta ≤ +50 °C)	
IECEX Certificate number	IECEX BAS 06.0057X	
ATEX Certificate number	Baseefa05ATEX0277X	
IS Input parameters	Input power	Ui = 18V, Ii = 800mA, Pi = 1.2W, Ci = 0µF, Li = 0mH
	4-20 mA	Ui = 30V, Ii = 200mA, Pi = 1.2W, Ci = 0µF, Li = 0mH
	(for information only please see certificate before installation)	
Zener Barriers are required.	Ask your installation engineers for installation/application advice.	

Zone 2 Installation:

Approval Marking	 II 3G Ex nA IIC T4 Gc (-40 °C ≤ Ta ≤ +50 °C)		
Certificate number	IonScience09849X		
Input parameters	Input power	Ui = 24 V	
	4-20 mA	Ui = 35 V	
	(for information only please see certificate before installation)		
Dimensions		Weight	
Height	188 mm (7.40")	Instrument	1.3 kg (2.9 lb)
Width	126 mm (4.96")	Packed	1.47 kg (3.2 lb)
Depth	78 mm (3.07")		
Display	7 Segment, 4 Digit LCD. 4 Colour LED's		
Response	Sensor T90 < 10 seconds		
	TVOC 2 output update: 1 second		
Accuracy	0 to 100 ppm: +/- 5 %		
	100 to 1000 ppm: +/- 10 %		
Linearity	0 to 1000 ppm >75 %		
Calibration	Magnetically accessed		
	ZERO = Carbon canister		
	SPAN = 100 ppm Isobutylene +/- 10 % or +/- 1 ppm (whichever is greater)		
Temperature	Operation: -20 °C to +50 °C (-4 °F to 122 °F)		
Humidity	0 – 95 % RH (non-condensing)		
EMC	Screened cables are required to archive the industrial immunity levels.		

NB: All specifications are against an isobutylene calibration at 20 °C, 50 % RH and up to 100 ppm unless otherwise indicated.

Manual Log

Manual Version	Amendment	Date updated	Instrument Firmware	PC Software
TVOC 2 Manual V1	New document for TVOC 2 instrument based on V4.7 of the original TVOC manual	04/07/19	V1.01	N/A
TVOC 2 Manual V1.1	Updated diagrams and Accuracy specification.	24/07/19	V1.01	N/A
TVOC 2 Manual v1.2	Put into new format Added more information to the calibration process Updated diagram 6	11/10/21	V1.01	N/A