

AIR-MET SCIENTIFIC

AirMetER-DX

MULTIPLE FRACTION PARTICLE MONITOR

User Manual



Before operating the unit, please read this user manual thoroughly and retain for future reference.

Revision | MARCH 2024

CONTENTS

Copyright Notice	3
Warnings, Cautionary Statements & Important Information	3
Warranty & Service	4
1. Overview	5
2. Monitor Assembly	6
Hardware V.2	6
Hardware V.3	7
Hardware DXIV	8
3. Detector Labeling	9
4. Installation	10
Conditions Of Use	10
Location & Mounting Of Monitor	10
5. LiveSense Cloud Portal	11
6. Maintenance	12
Maintenance Frequency	12
Troubleshooting	13
Filter Exchange	13
TSP Head Cleaning	15
Flow Rate Calibration	15
Frequency Tables	16
Annual Calibration	17
7. Field K Factor Adjustment	18
8. Spare Parts & Accessories	19
9. Specifications	20
Contact Information	0

COPYRIGHT NOTICE

These help materials or any part thereof may not, without the written consent of Air-Met Scientific, be copied, reprinted, or reproduced in any material form including but not limited to photocopying, transcribing, transmitting, or storing it in any medium or translating it into any language, in any form or by any means, be it digitally, electronic, mechanical, xerographic, optical, magnetic, or otherwise.

The information contained in this document is proprietary and confidential and all copyright, trademarks, trade names, patents, and other intellectual property rights in the documentation are the exclusive property of Air-Met Scientific unless otherwise specified. The information (including but not limited to data, drawings, specification, documentation, software listings, source or object code) shall not at any time be disclosed directly or indirectly to any third party without prior written consent.

The information contained herein is believed to be accurate and reliable. Air-Met Scientific accepts no responsibility for its use by any means or in any way whatsoever. Air-Met Scientific shall not be liable for any expenses, costs by damage that may result from the use of the information contained within this document. Although every effort is made to ensure accuracy, the specifications of this product and the content herein are subject to change without notice.

WARNINGS, CAUTIONARY STATEMENTS & IMPORTANT INFORMATION

Throughout this manual any warnings, cautionary statements or notes of importance are identified using the following symbols:

	IMPORTANT INFORMATION
---	------------------------------

WARRANTY & SERVICE

Air-Met Scientific maintains instrument service facilities nationwide. Should your instrument require service, you may contact us on **1800 000 744** or at service@airmet.com.au. Alternatively, instrument service may be booked by completing our online service request form at the following URL:

<https://www.airmet.com.au/services/book-a-service>

For non-warranty repairs, you will need to provide a purchase order number. All instruments submitted for repair will undergo evaluation by a service technician and a quote for works required will be issued, for approval, before any service proceeds.

Please note that, if a service quote is declined, a small charge for instrument assessment may apply.

Air-Met Scientific's policy is to perform all repairs required to restore the instrument to full operating condition, including replacement of sensors and batteries (as applicable) that have exceeded the recommended service life and the completion of any manufacturer issued service dispositions.

The unit for repair may be sent to your local Air-Met Scientific branch office. Pack the instrument and all its accessories (preferably in its original packing). Include any special instructions, your contact and company details, and a description of the fault. Repairs are warranted for 90 days from the date of shipment. Sensors and other consumables have individual warranties.

	<p>Air-Met Scientific assumes no liability for work performed by unauthorised service facilities.</p>
---	--

The product specified in this manual is warranted against faulty workmanship for a period of 12 months, from the date of dispatch.

Our obligation assumed under this warranty is limited to the replacement of parts which, by our assessment, are proved to be defective and have not been misused, carelessly handled, defaced or damaged due to incorrect installation or operation. This warranty is VOID where the unit has been tampered with or if repairs have been made or attempted by anyone except an authorised representative of the manufacturing company.

Products for attention under the terms of this warranty (unless otherwise agreed) must be returned to the manufacturer, freight paid and, if accepted for free repair, will be returned to the customer's address in Australia free of charge.

When returning the product for service or repair a full description of the fault and the conditions of operation when the product failed must be given. In any event the manufacturer has no other obligation or liability beyond replacement or repair of this product. Modifications may be made, by the manufacturer, to any existing or future models of the unit as it may deem necessary without incurring any obligation to incorporate such modifications in units previously sold or to which this warranty may relate.

1. OVERVIEW

The AirMetER-DX is a remote area dust monitor for the simultaneous detection and measurement of particulate matter PM₁, PM_{2.5}, PM_{4.25}, PM₁₀ and TSP.

Designed to withstand various weather conditions, the AirMetER-DX is housed in a weather resistant enclosure ideal for round the clock continuous outdoor monitoring. The AirMetER-DX has datalogging capacity at a minimum of 365 days at one-minute intervals with built-in log and forward capability to locally store the data in the event of a network disruption.

Integrating seamlessly with the LiveSense cloud portal for remote data access, this secure data portal enables users to access monitoring logs, set customisable alerts, manage monitoring reports and more. The web-service application is accessible on both desktop PC and mobile smart devices.

The AirMetER-DX should be powered on 12VDC and is available with an optional Bluetooth enabled solar-power system that can provide up to 5 days autonomous operation.

For mains powered applications, an IP67 rated 240VAC to 12VDC 5A power supply is available.



AirMetER-DX | Proudly Australian Made

2. MONITOR ASSEMBLY

HARDWARE V.2

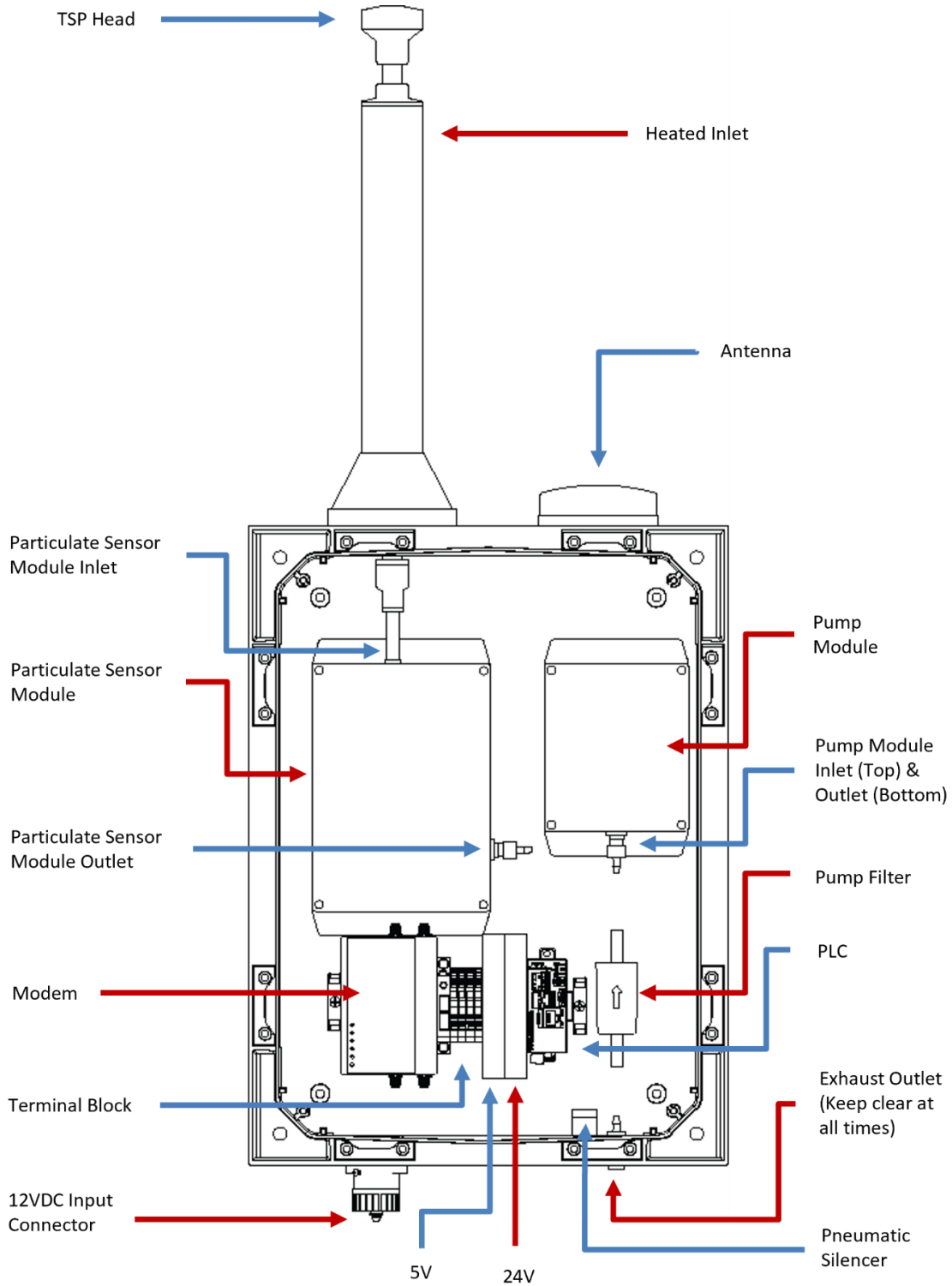

Parts may vary according to configuration

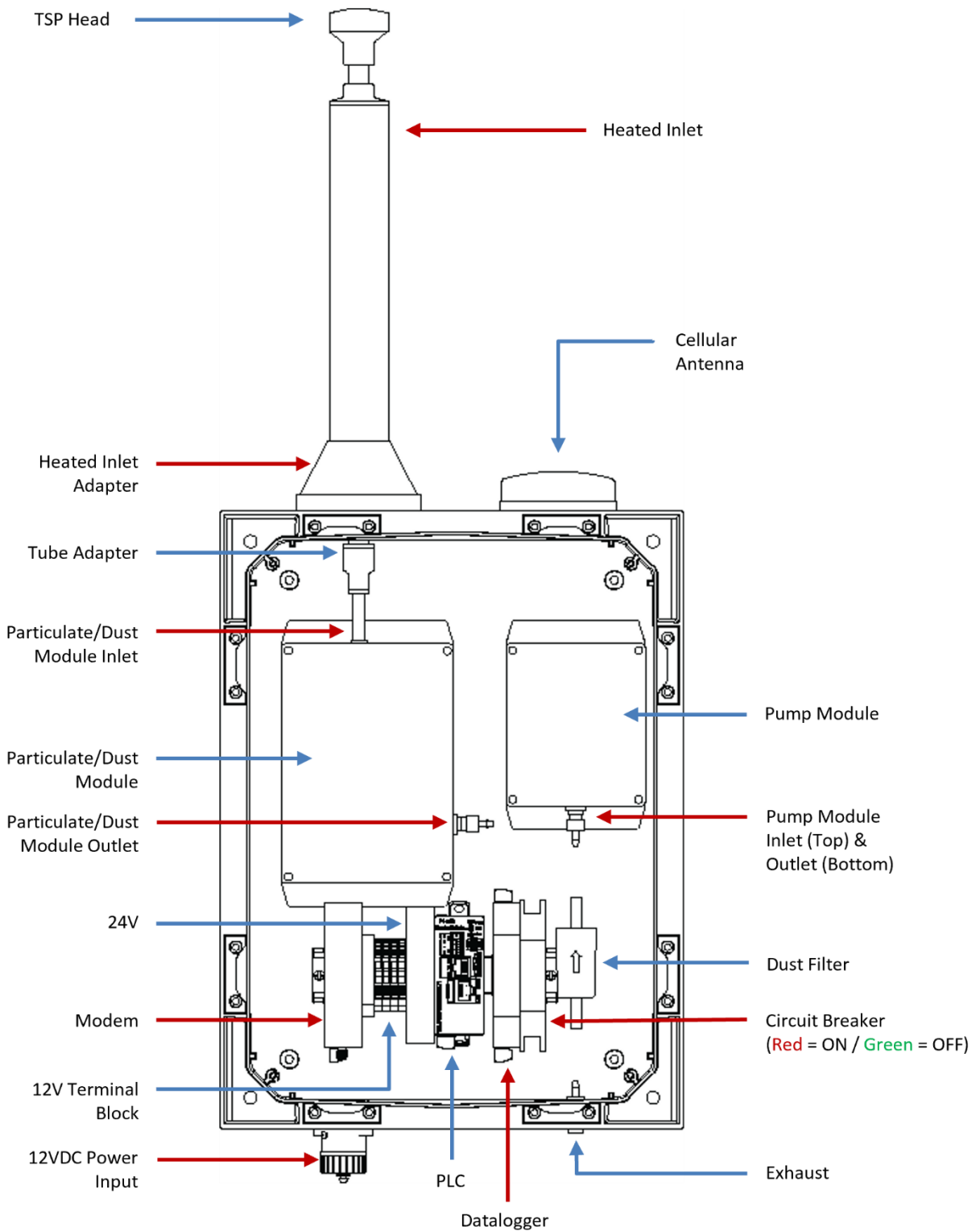

Parts may vary according to configuration

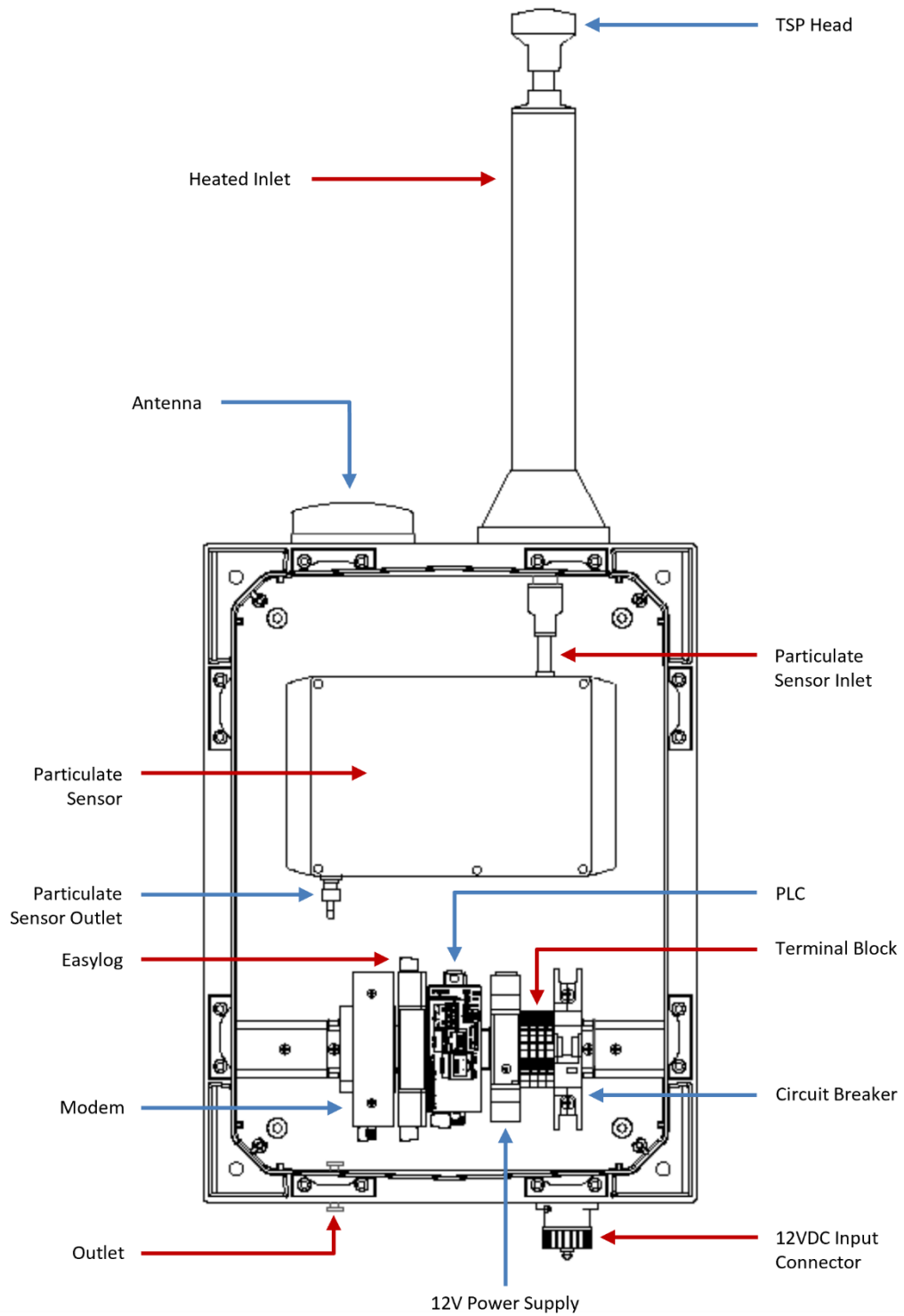

Parts may vary according to configuration

3. DETECTOR LABELING

Each detector is identified with the use of two labels. The labels contain the part and serial number information (Figure 3-1).

The labels can be located on the inside surface of the instrument door and on top of the particulate module.

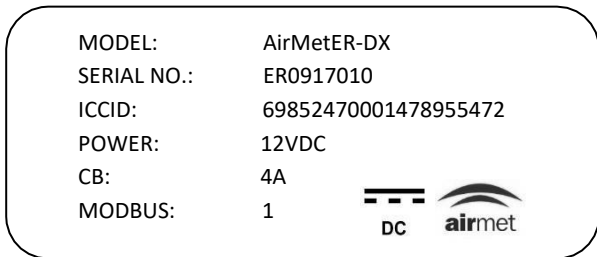
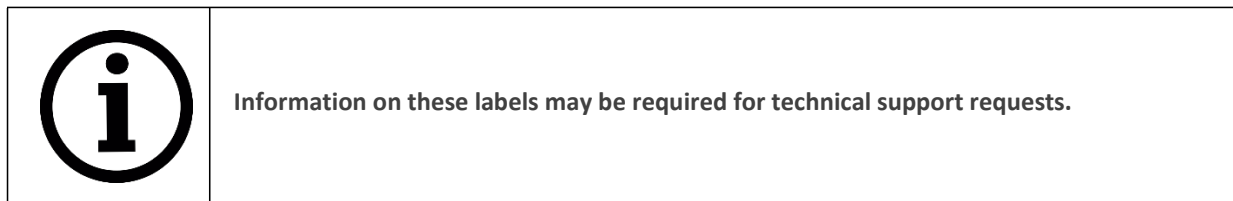

Figure 3-1 – Monitor Product Label Example



4. INSTALLATION



Use of the AirMetER-DX monitor in applications contrary to the conditions of use criteria may present a safety risk and/or void any instrument warranty.

CONDITIONS OF USE

The AirMetER-DX is **NOT** certified for use in hazardous area classified zones.

The AirMetER-DX is supplied with brackets pre-fitted to support standard pipe-clamp pole mount inserts suitable for installation on standard masts or poles ranging from 40-105mm in diameter. An adjustable spanner or flat-blade screwdriver may be utilised to either tighten or release the pipe clamp to suit the intended structure diameter. Care should be taken during installation to ensure the AirMetER-DX is level and firmly secured.



Figure 4-1 – Mounting Brackets



Figure 4-2 – Pre-Fitted Brackets

LOCATION & MOUNTING OF MONITOR

Air-Met Scientific recommends the monitor is pole or tripod mounted in an open area, free from buildings and other obstructions that may have an influence on measurements.

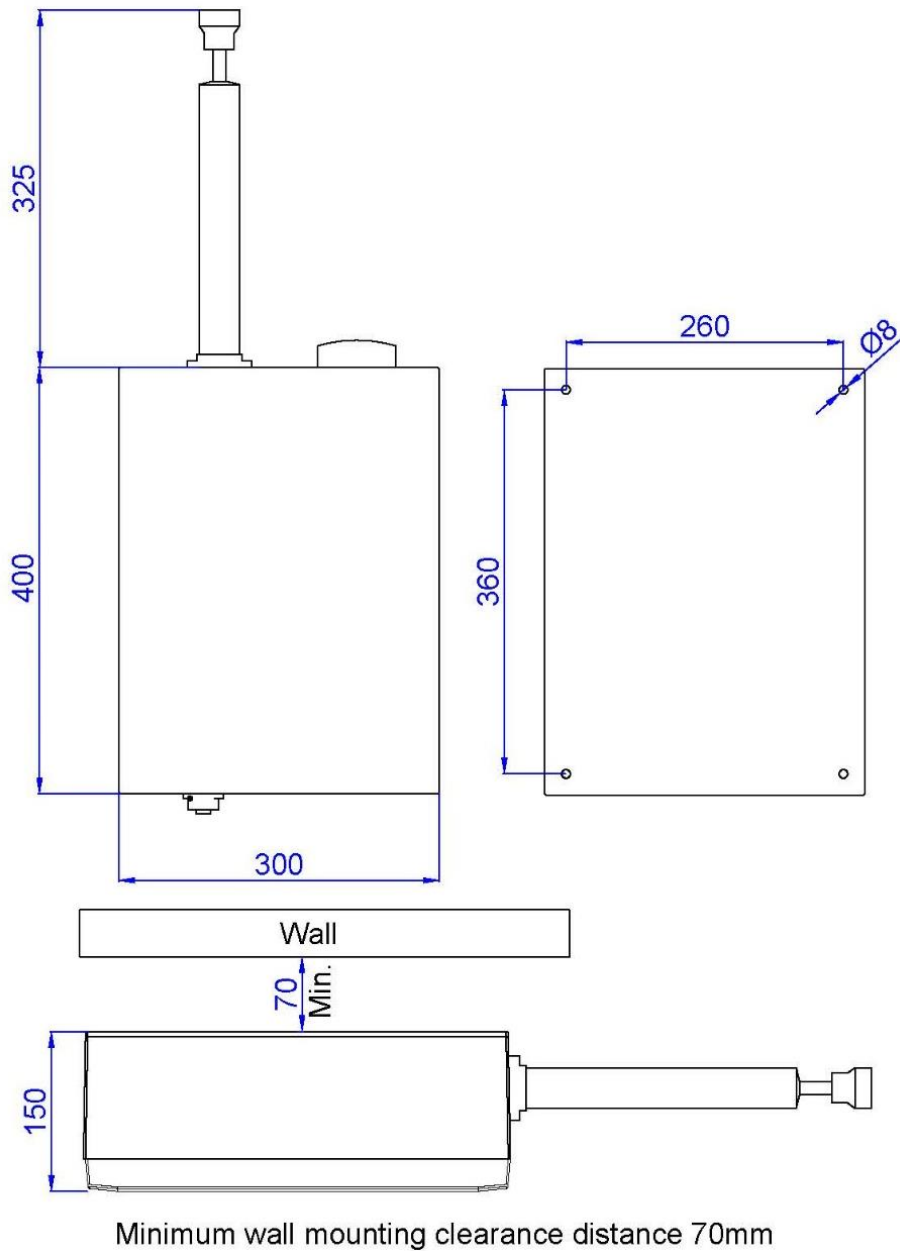

Figure 4-3 – External and Mounting-Point Dimensions (mm)

5. LIVESENSE CLOUD PORTAL

To access the LiveSense cloud platform, enter [https:// airmetapp.livesense.com.au/login](https://airmetapp.livesense.com.au/login) into your browser and sign in using the credentials provided to you by your administrator.

The username is generally your e-mail address, unless specified otherwise. If you cannot remember your password, you may utilise the ‘forgot password’ function to reset this.

Sign into your account

LOGIN
User Name
THIS FIELD IS REQUIRED.

PASSWORD
Credentials
THIS FIELD IS REQUIRED.

[Forgot password?](#)

By default, this station will be setup with an activity alarm ‘Comms Alarm’ and basic graphical widgets on your dashboard.

Should you wish to modify your platform, please refer to Air-Met Scientific’s ‘LiveSense User Guide’ for a complete overview of basic and more advanced functions available.

For further assistance or troubleshooting, contact engineeredolutions@airmet.com.au

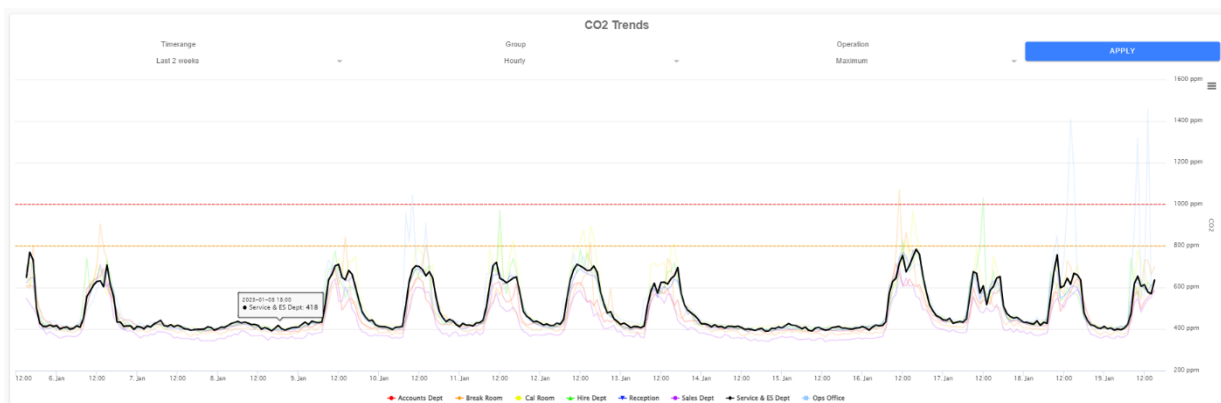

6. MAINTENANCE

MAINTENANCE FREQUENCY

Air-Met Scientific recommends a maximum maintenance interval of 12 months.

	<p>Specified maintenance and calibration intervals are recommendations only. A maintenance plan suitable for the application should be discussed internally. Alternatively, Air-Met Scientific can assist with this through a service agreement.</p>
---	---

	<p>Only trained technicians should attempt any disassembly or repairs on the AirMetER-DX.</p>
---	--

ISSUE	SOLUTIONS
I. No air flow at the exhaust	<ol style="list-style-type: none"> 1. Is the pump plugged in at the top as displayed in <i>Figure 6-16</i>? 2. Is the dust filter blocked and need replacement? 3. Trace the tubing from the heated inlet > particulate sensor module > dust filter > pump module > external exhaust for any signs of leaks or blockages. 4. Follow the Flow Rate Calibration section below to adjust the flow rate.
II. Air flow at the inlet not within the below tolerance. DXII 2L/m \pm 5% DXIV 1L/m \pm 5%	<ol style="list-style-type: none"> 1. Is the dust filter blocked and need replacement? 2. Is the pump plugged in at the top as displayed in <i>Figure 6-16</i>? 3. Are the heated inlet and particulate sensor modules connected by the tube adapter? 4. Trace the tubing from the heated inlet > particulate sensor module > dust filter > pump module > external exhaust for any signs of leaks or blockages. 5. Follow the Flow Rate Calibration section below to adjust the flow rate.
III. Readings are low	<ol style="list-style-type: none"> 1. Is the instrument due for calibration or service? 2. Is the dust filter polluted and need replacement? 3. Is the pump plugged in at the top as displayed in <i>Figure 6-16</i>? 4. Is the heated inlet and particulate sensor module connected by the tube adapter? 5. Trace the tubing from the heated inlet > particulate sensor module > pump filter > pump module > external exhaust for any signs of leaks or blockages. 6. Follow the Flow Rate Calibration section below to adjust the flow rate.
IV. Pump not running	<ol style="list-style-type: none"> 1. Is the pump plugged in at the top as displayed in <i>Figure 6-16</i>? 2. Is the modem on? If both the modem and pump are not on, then the unit may not be powered on. 3. Check the fuse / circuit breaker and power supply.
V. Data not uploading to LiveSense	<ol style="list-style-type: none"> 1. Is the modem plugged in? 2. Check the fuse / circuit breaker and power supply. 3. Is the uSD card installed in the easylog? (Hardware V.3) 4. Does the instrument have connection to the internet through your specific connection method? (Cellular, Wi-Fi or ethernet) 5. Is the cellular or Wi-Fi antenna correctly installed?
VI. Instrument not turning on	<ol style="list-style-type: none"> 1. Check the fuse / circuit breaker and power supply. 2. Using a multimeter, check that the instrument is receiving 12VDC from the power supply.

FILTER EXCHANGE

The AirMetER-DX contains up to two filters:

- > 9933-05-CQ / 121-5866 – DXII filter
SF-OPC6303-15-QN – DXIV filter
- > 121-5866 – Pneumatic silencer

The pneumatic silencer is installed on AirMetER-DX instruments manufactured before February 2023. This only requires replacement when polluted or damaged. It is recommended that the dust filter be exchanged no less than annually. The filters should be monitored and inspected at regular intervals in new applications to gain an insight into how long the filters last before discolouration.



It should be noted that the frequency of filter exchanges may be affected by the application and location of the device.



Figure 6-1 – Complete assembly
DXII (setup may vary)

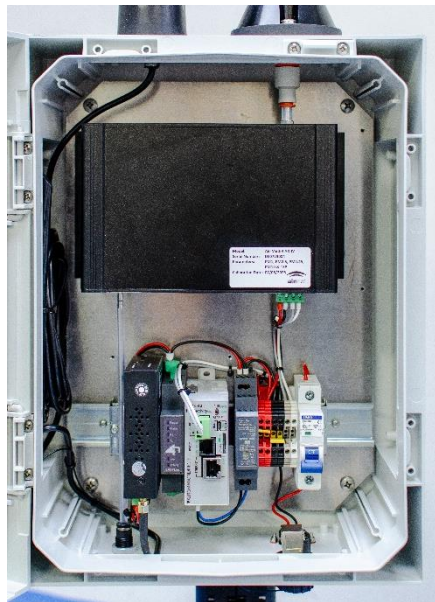

Figure 6-2 – Complete assembly
DXIV (setup may vary)



Figure 6-3 – Dust Filter (DXII)



Figure 6-4 – Dust Filter (DXIV)



Figure 6-5 – Pneumatic Silencer

DXII MODEL

The dust filter is secured to the tubing with push fittings. Compress the push fitting to release the filter from the fitting. Ensure when installing the new filter to properly click the filter in place into both push fittings, keeping the directional arrow pointing towards the pump.

After completing the pump filter exchange, it is important to again validate the inlet flowrate to ensure no leaks have been created during this process. The inlet flowrate is set to 2L/m \pm 5%, as detailed in the [flow rate calibration](#) section below.

The pneumatic silencer can be removed by unscrewing it anti-clockwise before replacing it with the new silencer. Take care to ensure the O-ring does not fall off the new silencer when replacing.

DXIV MODEL

Equipment Required:

- PH screwdriver
- 2mm allen key
- Verified Rotameter capable of displaying 1L/m
- 3/8" flexible tubing

WARNING:

Do not use a power drill on the particulate sensor module screws as this may cause damage to the instrument. Ensure that the AirMetER-DX is switched off and disconnected from any power source while removing and replacing the particulate sensor module.

1. Remove the outlet tubing from the particulate sensor module by pulling the tubing from the barb fitting (If firm, using a heat gun will help).
2. Using a 2mm allen key, loosen the grub screw to ensure that the heated inlet can slide to assist with step 3.
3. Unplug the tube adapter from the heated inlet by compressing the orange section inwards. This will release the tube adapter. Slide the heated inlet upward until it is released.
4. Remove the four screws from the sides of the particulate sensor module.
5. Unplug the green phoenix connector, disconnecting the data output and power from the device.
6. Remove four PH screws from the lid of the module.
7. Swing the lid away from the box, taking care not to disconnect or damage internal tubing.
8. Unclip the filter from the filter holder and disconnect tubing from either side using push-fitting connections.
9. Disassemble the filter and replace the cartridge if polluted.



Figure 6-6 – Particulate Sensor Module



Figure 6-7 – Outlet Tubing



Figure 6-8 – Heated Inlet

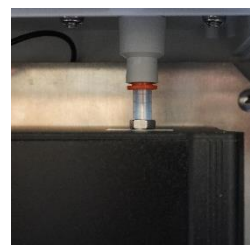

Figure 6-9 – Tube Adaptor

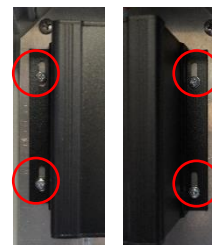

Figure 6-10 – Screw Locations (Step 4)



Figure 6-11 – Phoenix Connector



Figure 6-12 – Screw Locations (Step 6)



Figure 6-13 – Module Lid



Figure 6-14 – Filter

TSP HEAD CLEANING

A TSP head should be installed on all heated inlets at factory and while installed in the field, these need to be periodically cleaned. The time interval between cleaning varies depending on the application and location of the device. It is recommended to clean and check for any blockages within the TSP head and heated inlet assembly during annual routine maintenance.

Some instruments will have a PM₁₀ sharp cut cyclone (AE10-2) installed instead of the standard TSP head. These are used in applications where high levels of particulates larger than PM₁₀ are found and need to be filtered out as to not damage the sensor. When the sharp cut cyclone is being used, it needs to be monitored and cleaned at a much higher frequency.



Figure 6-15 – TSP Head

This process may be completed using a brush and compressed air if available.

FLOW RATE CALIBRATION

DXII MODEL

Attach a 0.4-5L/m rotameter (320-4A5) to the inlet of the AirMetER-DX. The flowmeter should indicate 2L/m \pm 5%. Should this be out of tolerance, check to ensure there are no leaks and that there is pressure when blocking the heated inlet. Manual adjustment of the pump flow meter may be completed to achieve this as depicted below.

Unscrew 4x PH screws from the AirMetER AX-P top case (NOTE: these screws are retaining).



Figure 6-16 – Pump Top

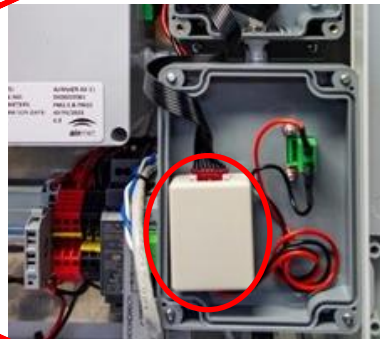

Figure 6-17 – Pump Internal

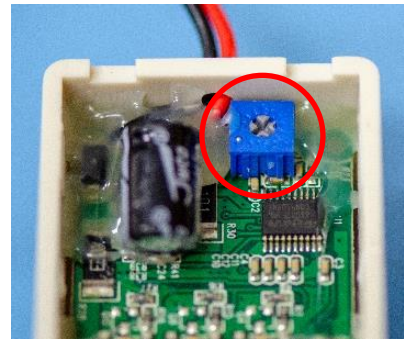

Figure 6-18 – Pump Control Internal

Using a small flat-blade driver, remove the lid from the control box within the pump module.

Adjust the potentiometer clockwise to increase the flowrate and anti-clockwise to decrease the flowrate in order to achieve 2L/m \pm 5%.

In the event the flowrate cannot maintain 2L/m \pm 5% at the inlet, losses can be diagnosed throughout the flow path: Heated inlet > particulate sensor module > dust filter > pump module > external exhaust

DXIV MODEL

The flow rate is actively monitored and reported by the instrument in real-time. Should the flow rate deviate from the performance specification of 1L/m \pm 5%, the device should be reviewed.

Clean the TSP inlet adaptor and heated inlet to clear any potential debris. Should this fail to rectify the flow rate readings, contact your local Air-Met Service department to organise further technical support.

FREQUENCY TABLES

CALIBRATION FREQUENCY TABLE

DESCRIPTION	CALIBRATION FREQUENCY
Particulate Sensor	Yearly
Pump Module	Yearly (additionally when the dust filter is replaced or the heated inlet is removed)

FILTER REPLACEMENT TABLE

FILTER DESCRIPTION	PART NUMBER	REPLACEMENT FREQUENCY
Dust Filter (DXII)	9933-05-CQ	Yearly*
Dust Filter (DXIV)	SF-OPC6303-15-QN	Yearly*
Pneumatic Silencer	121-5866	Only when polluted or damaged

* *Dependent on the application of the instrument*

MODULE REPLACEMENT TABLE

MODULE DESCRIPTION	PART NUMBER	RECOMMENDED REPLACEMENT CYCLE
Particulate Sensor	Air-MetER AX-11 & Air-MetER AX-IV	2 years
Pump	TM30A-D12-V7004	2 years

ANNUAL CALIBRATION

In order for the AirMetER-DX module to be calibrated, it must be returned to the Air-Met Scientific Head Office in Melbourne. For a guide on how to remove the AirMetER-DX module and all other modules, please refer to our [Particulate Sensor Module Removal and Replacement Quick Guide](#).

Air-Met Service Facilities perform repairs and part services, as well as calibrations and adjustments. Air-Met Scientific offers calibration reminder programs and maintenance contracts for the AirMetER-DX.

For further details, please feel free to contact us at any of the following means:



Alternatively, scan the QR code to locate your nearest Air-Met Scientific office.

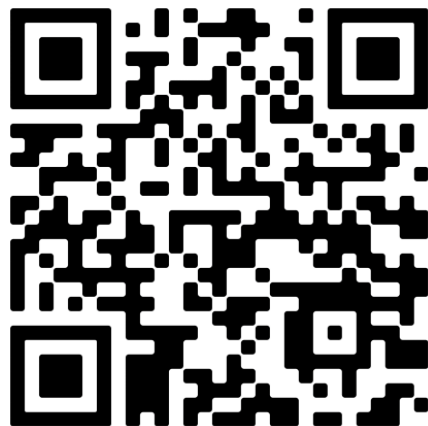

7. FIELD K FACTOR ADJUSTMENT

Field calibration (K Factor Adjustment) of the AirMetER-DX is an important process to ensure data accuracy with respect to the location of the instrument. Field calibration should not be considered a substitute for factory calibration.

In order to perform a K Factor adjustment, a gravimetric sample must be collected relative to the newly installed instrument.

NOTE: Ensure correct methods for conducting a gravimetric sample are followed to ensure an accurate K Factor adjustment – If unsure regarding this process please contact Air-Met Scientific.

Provide collected data to Air-Met Scientific and a K Factor adjustment may be completed remotely.

8. SPARE PARTS & ACCESSORIES

ITEM	PART NUMBER
Tripod	TF-TRI-AL
170 Ah Lead-Acid Solar Battery Kit	AMS/200S/170B/15M/9C
150 Ah Lithium Solar Battery Kit	AMS/200S/150B/15M/9C
TSP Head	10085
PM ₁₀ Cyclone Head	AE10-2
Heated Inlet	10090-2
Power Supply (240V)	LPF-60-12-AUP
Pneumatic Silencer	121-5866
Dust Filter (DXII)	9933-05-CQ
Dust Filter (DXIV)	SF-OPC6303-15-QN
Pump	TM30A-D12-V7004
Meteorological Sensors	Upon Request
Luer Fittings and Tubing	Upon Request
Particulate Sensor	Air-MetER AX-11 & Air-MetER AX-IV
0.4L – 5L Rotameter	320-4A5

9. SPECIFICATIONS

GENERAL	
Power Requirement	12VDC
Rated Power	33W
Operating Temperature	0°C to 50°C
Operating Humidity	0 to 95% non-condensing
Operating Pressure	860 to 1100 hPa
Particulate Sensor Operating Life	2 years (when operated below 40°C)
Datalogging (optional)	3 years of logs onboard with unique file name creation every 24 hours
Alarm Indicator (optional)	Onboard dedicated alarm relays

ENCLOSURE	
Material	Polycarbonate
Dimensions (mm)	400 (H) x 300 (W) x 150 (D)
Instrument Weight	7.0kg
Mounting Options	Pole-mount kit supplied (recommended installation method) Wall-mount – ~70 mm offset required for dust inlet clearance

COMMUNICATION	
PLC or SCADA Integration	Serial RS485
FTP Upload	Cellular (Ethernet or Wi-Fi upon request)

PARTICULATE MEASUREMENTS		
	AirMetER-DXII (PM _{2.5} & PM ₁₀)	AirMetER-DXIV (PM ₁ , PM _{2.5} , PM _{4.25} , PM ₁₀ and TSP)
Range	0–999.9µg/m ³	0–30,000µg/m ³
Resolution	0.1µg/m ³	1µg/m ³
Relative Error	Max of ±15% and ±10µg/m ³	PM ₁ /PM _{2.5} /PM _{4.25} ±10% of reading PM ₁₀ ±15% of reading TSP ±20% of reading } Up to 1000µg/m ³

CONTACT INFORMATION

AIR-MET SCIENTIFIC PTY LTD

Head Office

7-11 Ceylon Street
Nunawading VIC 3131
Australia

Postal Address

P.O. Box 133
Nunawading VIC 3131
Australia

Phone: 1800 000 744
+61 3 8878 3300

Web: www.airmet.com.au
Email: sales@airmet.com.au

Air-Met Scientific Pty Ltd, Australia
© 2024 Air-Met Scientific
All rights reserved.