

Low Profile Air Strippers

Geotech LO-PRO™

Geotech LO-PRO™ Models II and III are highly efficient water treatment systems that can remove up to 99.99% of many volatile organic compounds (VOCs) from water.

Systems are self-contained for use in limited space applications.

FEATURES

- Patented multi-stage counterflow aeration provides up to 99.99% removal efficiency.
- Features vacuum induced draft design that is more efficient than forced draft and eliminates fluid leakage between trays.
- Low profile modular design requires less floor and head space.
- Lightweight modular polyethylene trays allows the addition or subtraction of trays to meet engineered treatment requirements.
- Stainless steel bubble plate design resists fouling.
- Highly effective on BTEX, MTBE, and Radon.
- Very easy to install and maintain.
- Remote monitoring and troubleshooting capability with the optional Geotech ECM.

OPERATION

Contaminated water enters the Geotech LO-PRO™ at the top of the unit and cascades onto the first of a series of stainless steel bubble plates. A baffle in the center of each plate redirects the water 180° in each stage as it flows downward, alternating between clockwise and counter-clockwise directions. This action optimizes the residence time of the water in the Geotech LO-PRO™, allowing for efficient contaminant removal.



Geotech LO-PRO™ Model II

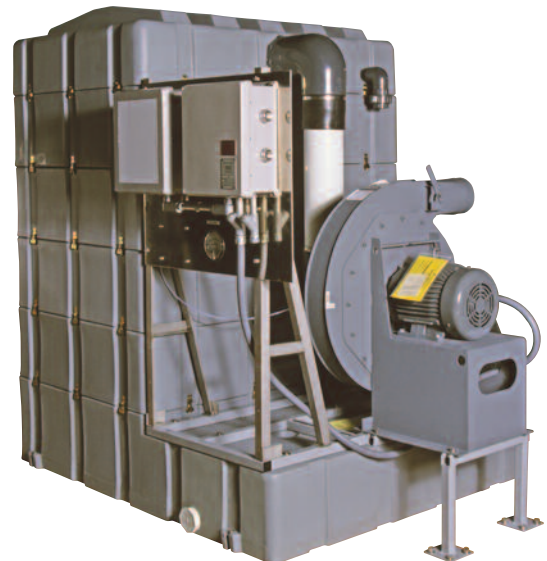

Geotech LO-PRO™ Model III S

CALL GEOTECH TODAY (800) 833-7958

Geotech Environmental Equipment, Inc.

2650 East 40th Avenue • Denver, Colorado 80205

(303) 320-4764 • (800) 833-7958 • FAX (303) 322-7242

email: sales@geotechenv.com website: www.geotechenv.com

Low Profile Air Strippers

Geotech LO-PRO™

KEY COMPONENTS OF THE LO-PRO

- 1 Lightweight polyethylene construction
- 2 Threaded coupling for easy assembly
- 3 Stainless steel bubble plates
- 4 Multi-stage counterflow aeration
- 5 Blower
- 6 Blower pressure gauge
- 7 Air inlet
- 8 Sump water level sensor
- 9 Hand operated latches

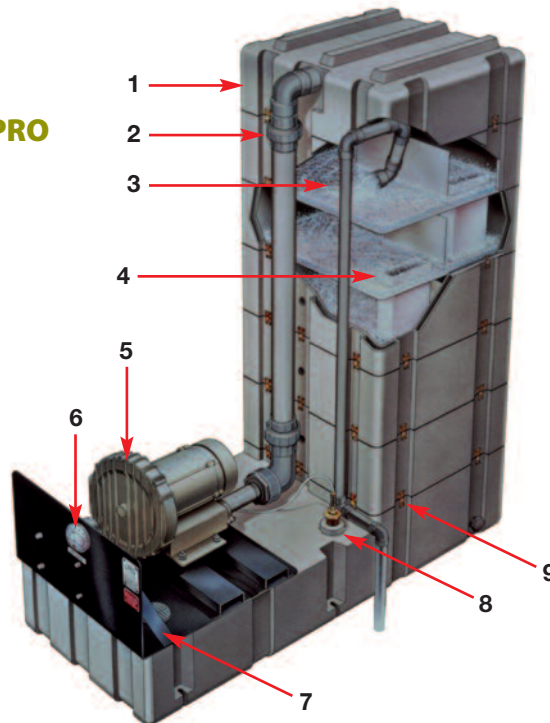

SPECIFICATIONS

| | LO-PRO Model II | LO-PRO Model III |
|------------------------------|---|---|
| Applications: | For use in non-classified and Class 1, Div. 2 locations | High flow-rate for use in non-classified and Class 1, Div. 2 locations |
| Dimensions: | 5 tray unit: 66"L x 27"W x 75"H Each additional tray adds 10" to height | 3 tray unit: 91"L x 60"W x 70"H Each additional tray adds 13" to height |
| Maximum No. of Trays: | 8 | 5 |
| Material: | Linear Low Density Polyethylene Housing Stainless steel bubble plates | Light Weight Polyethylene Housing Stainless steel bubble plates |
| Water Flow: | 1-20 gpm (4-76 l/min) | 1-60 gpm (4-227 l/min) |
| Air Flow: | Up to 250 CFM (7.1 CMM) | Up to 1100 CFM (31 CMM) |
| Blower HP: | 1-5 HP regenerative blower (TEFC: for use in Class 1, Div. 2 locations) | 10-15 HP centrifugal blower (TEFC: for use in Class 1, Div. 2 locations) |
| Blower Voltage: | 208-230/460V, 50 Hz or 60 Hz, 3 phase Single phase available | 208-230/460V, 50 Hz or 60 Hz, 3 phase |
| Options: | High pressure switch assembly, low pressure switch assembly, Geotech ECM controls and telemetry, motor starter package, sump water level sensor, additional trays, CFM gauge and valve assembly, transfer pumps. Explosion-proof blower. | High pressure switch assembly, low pressure switch assembly, Geotech ECM controls and telemetry, motor starter package, sump water level sensor, additional trays, CFM gauge and valve assembly, transfer pumps. Explosion-proof blower. |

CALL GEOTECH TODAY (800) 833-7958

Geotech Environmental Equipment, Inc.

2650 East 40th Avenue • Denver, Colorado 80205
 (303) 320-4764 • **(800) 833-7958** • FAX (303) 322-7242
 email: sales@geotechenv.com website: www.geotechenv.com