



Geotech 3.5 Reclaimer

Installation and Operation Manual



TABLE OF CONTENTS

CHAPTER 1: SYSTEM DESCRIPTION	3
FUNCTION AND THEORY	3
CHAPTER 2: SYSTEM INSTALLATION	4
CHAPTER 3: SYSTEM OPERATION.....	5
CHAPTER 4: SYSTEM MAINTENANCE	7
CHAPTER 5: SYSTEM TROUBLESHOOTING	9
CHAPTER 6: SYSTEM SPECIFICATIONS.....	10
CHAPTER 7: REPLACEMENT PARTS LIST	12
THE WARRANTY	14
EQUIPMENT RETURN POLICY.....	14
EQUIPMENT DECONTAMINATION.....	14

DOCUMENTATION CONVENTIONS

This manual uses the following conventions to present information:



WARNING

An exclamation point icon indicates a **WARNING** of a situation or condition that could lead to personal injury or death. You should not proceed until you read and thoroughly understand the **WARNING** message.



CAUTION

A raised hand icon indicates **CAUTION** information that relates to a situation or condition that could lead to equipment malfunction or damage. You should not proceed until you read and thoroughly understand the **CAUTION** message.



NOTE

A note icon indicates **NOTE** information. Notes provide additional or supplementary information about an activity or concept.

Chapter 1: System Description

Function and Theory

The Geotech Reclaimer can be configured as a Top fill, Bottom fill, or Top and Bottom fill fixed intake, positive air displacement pump. The Geotech Reclaimer is designed for total fluids, hydrocarbon, leachate, and condensate recovery. The Geotech Reclaimer is designed to withstand most aggressive down well environments including highly corrosive fluids without fear of material breakdown or failure.



The Geotech Reclaimer will recover fluids from depths up to 500' (152 m). Refer to the operation section of this manual.

Flow rates of up to 4 GPM (15 LPM) are possible. Refer to the specifications section of this manual.

The Geotech 3.5" Reclaimer will operate in wells 4" (10 cm) inside diameter or larger vertical wells.

Chapter 2: System Installation

Attach product discharge and air supply hoses to the proper barbed fittings on the pump. Refer to Figures 1 and 2 below for fitting configurations.



If pump configuration was not assembled as a complete system, please use the following steps:

Attach air supply hose to Geotech pneumatic controller air supply fitting.

Ensure all hoses are installed properly and securely to the fittings.

Attach the safety cable to the support loop using proper crimps or cable clamps.

The Reclaimer can now be lowered into the recovery well. For optimum efficiency, the Reclaimer must be positioned in the well with the intake adequately submerged.



Figure 1
3.5" Reclaimer Bottom Fill

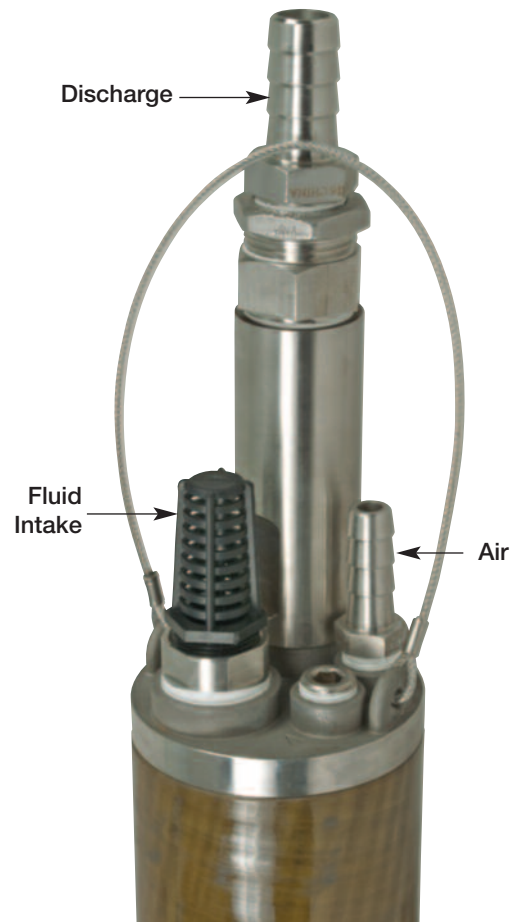

Figure 2
3.5" Reclaimer Top Fill

Chapter 3: System Operation



Compressed air is utilized in this system. For pressure requirements use .5 psi per foot (.03 bar per 30.5 cm) of lift plus ten. Example: 30' (9 m) of head would need a minimum of 25 psi (1.7 bar). Consult the controller manual for air pressure requirements needed.

TOP FILL

The Top Fill Reclaimer is placed in a recovery well with the top inlet submerged below static groundwater. Combined with the Geotech Pneumatic Controller, the Reclaimer cyclically fills and empties.



Well recharge rate and time sequence settings on the Geotech Pneumatic Controller will affect the maintainable fluid level.

BOTTOM FILL

The Bottom Fill Reclaimer is placed in a recovery well with the bottom intake submerged below static groundwater. Combined with Geotech's Pneumatic Controller, the Reclaimer cyclically fills and empties.



Well recharge rate and time sequence settings on the Geotech Pneumatic Controller will affect the maintainable fluid level, see Figure 3.

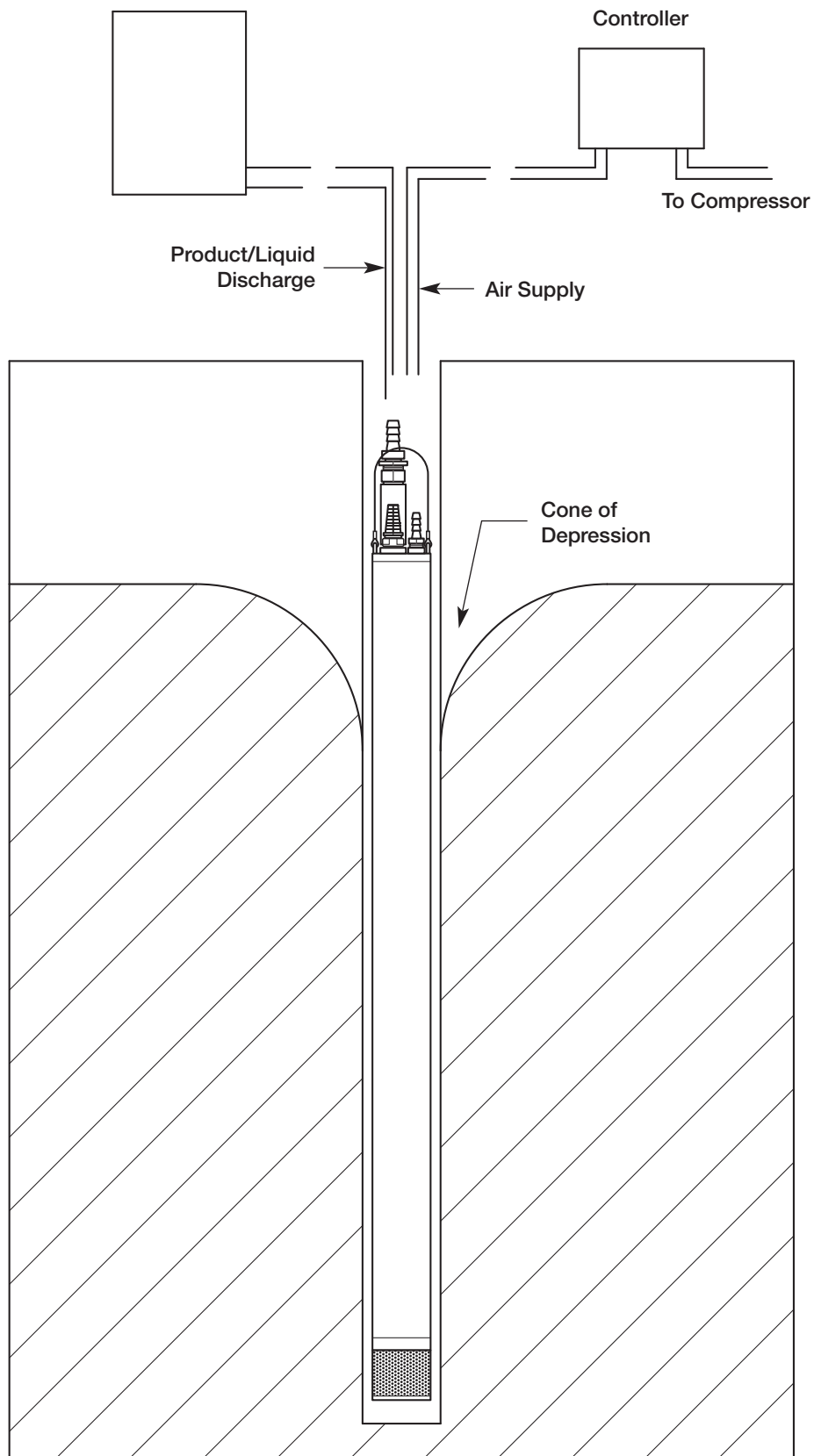
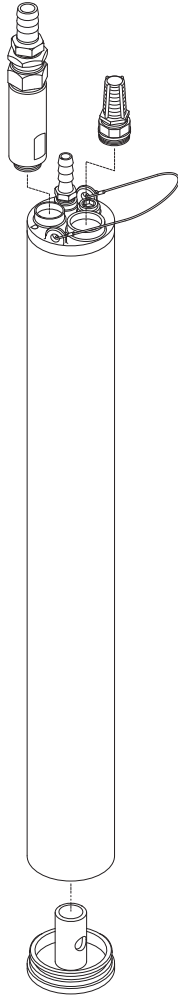

Figure 3
3.5" Reclaimer

Chapter 4: System Maintenance

The Geotech Reclaimer has been designed to be virtually maintenance free. In the event clogging occurs in the pump or trapped particulate in the check ball seats, disassemble the Reclaimer pump and rinse with soapy or clean water to dislodge any matter. The Reclaimer is constructed of 300 series stainless steel and PTFE to provide many years of continued service with minimal maintenance. See Figure 4.

Top Fill



Bottom Fill

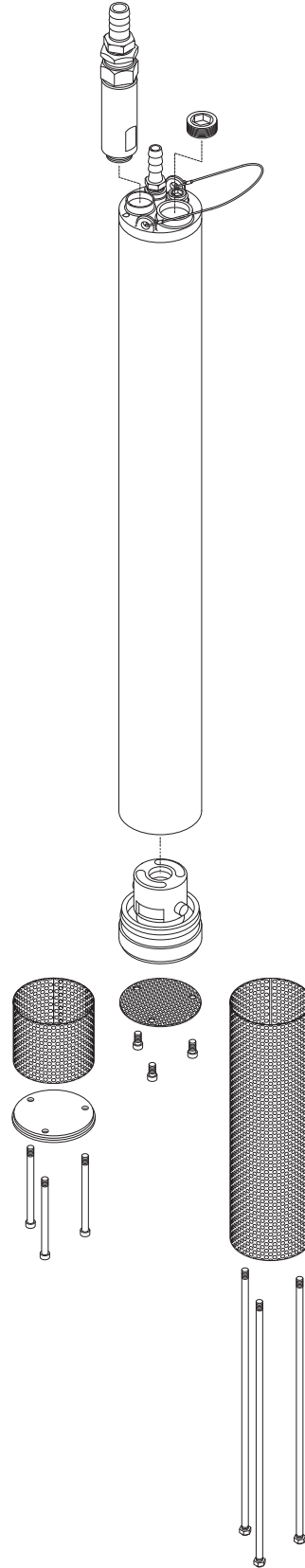

Figure 4

Chapter 5: System Troubleshooting

Problem: Pump does not discharge fluid to the surface.

Solutions:

1. Check controller to ensure it is functioning properly. Consult controller manual.
2. Ensure that the air pressure is adequate enough to overcome the total dynamic head pressure the pump is working against. (Consult the controller manual for air pressure requirements needed.)
3. Inlet screen is clogged – Remove pump from well, disassemble, clean screen
4. Inlet pipe plug is clogged – Remove pump from well, disassemble, clear, clean plug
5. Air exhaust vent hose is clogged – Remove pump from well, disassemble, clear vent hose
6. Hoses are kinked or cut – Replace damaged hoses

Chapter 6: System Specifications

3.5" Reclaimer

Outside Diameter 3.5" (8.9 cm)
 Max. Operating Depth 500' (152 m)
 Min. Well ID 4" (10 cm)
 Max. Flowrate 4 GPM (15 LPM)
 Fittings Stainless Steel
 Fluid Discharge 1"
 Air Supply 1/2"

3.5 Re claimer	Dimensions - inches (cm)			Weight lbs. (kg)	Volume/Cycle gallons (liters)	Max. Flow Rate GPM (LPM)
	A	B	C			
24" Top Fill	24 (61)	0	32 (81.3)	12.0 (5.4)	0.5 (1.9)	3 (11.4)
24" Bottom Fill (No Screen)	24 (61)	0	32 (81.3)	12.0 (5.4)	0.5 (1.9)	3 (11.4)
24" Bottom Fill (Flat Screen)	24 (61)	0.5 (1.3)	32.5 (82.5)	12.0 (5.4)	0.5 (1.9)	3 (11.4)
24" Bottom Fill (3" Screen)	24 (61)	3 (7.6)	35 (88.9)	12.3 (5.6)	0.5 (1.9)	3 (11.4)
24" Bottom Fill (12" Screen)	24 (61)	12 (30.5)	44 (111.8)	13.8 (6.3)	0.5 (1.9)	3 (11.4)
24" Top & Bottom Fill (No Screen)	24 (61)	0	32 (81.3)	12.0 (5.4)	0.5 (1.9)	3 (11.4)
24" Top & Bottom Fill (Flat Screen)	24 (61)	0.5 (1.3)	32.5 (82.5)	12.0 (5.4)	0.5 (1.9)	3 (11.4)
24" Top & Bottom Fill (3" Screen)	24 (61)	3 (7.6)	35 (88.9)	12.3 (5.6)	0.5 (1.9)	3 (11.4)
24" Top & Bottom Fill (12" Screen)	24 (61)	12 (30.5)	44 (111.8)	13.8 (6.3)	0.5 (1.9)	3 (11.4)
36" Top Fill	36 (91)	0	44 (111.8)	14.8 (6.7)	1 (3.8)	3.6 (13.6)
36" Bottom Fill (No Screen)	36 (91)	0	44 (111.8)	14.8 (6.7)	1 (3.8)	3.6 (13.6)
36" Bottom Fill (Flat Screen)	36 (91)	0.5 (1.3)	44.5 (113)	14.8 (6.7)	1 (3.8)	3.6 (13.6)
36" Bottom Fill (3" Screen)	36 (91)	3 (7.6)	47 (119.4)	15.0 (6.8)	1 (3.8)	3.6 (13.6)
36" Bottom Fill (12" Screen)	36 (91)	12 (30.5)	56 (142.2)	16.5 (7.5)	1 (3.8)	3.6 (13.6)
36" Top & Bottom Fill (No Screen)	36 (91)	0	44 (111.8)	14.8 (6.7)	1 (3.8)	3.6 (13.6)
36" Top & Bottom Fill (Flat Screen)	36 (91)	0.5 (1.3)	44.5 (113)	14.8 (6.7)	1 (3.8)	3.6 (13.6)
36" Top & Bottom Fill (3" Screen)	36 (91)	3 (7.6)	47 (119.4)	15.0 (6.8)	1 (3.8)	3.6 (13.6)
36" Top & Bottom Fill (12" Screen)	36 (91)	12 (30.5)	56 (142.2)	16.5 (7.5)	1 (3.8)	3.6 (13.6)
48" Top Fill	48 (122)	0	56 (142.2)	16.3 (7.4)	1.3 (4.9)	4 (15.1)
48" Bottom Fill (No Screen)	48 (122)	0	56 (142.2)	16.3 (7.4)	1.3 (4.9)	4 (15.1)
48" Bottom Fill (Flat Screen)	48 (122)	0.5 (1.3)	56.5 (143.5)	16.3 (7.4)	1.3 (4.9)	4 (15.1)
48" Bottom Fill (3" Screen)	48 (122)	3 (7.6)	59 (149.9)	16.5 (7.5)	1.3 (4.9)	4 (15.1)
48" Bottom Fill (12" Screen)	48 (122)	12 (30.5)	68 (172.7)	18.0 (8.2)	1.3 (4.9)	4 (15.1)
48" Top & Bottom Fill (No Screen)	48 (122)	0	56 (142.2)	16.3 (7.4)	1.3 (4.9)	4 (15.1)
48" Top & Bottom Fill (Flat Screen)	48 (122)	0.5 (1.3)	56.5 (143.5)	16.3 (7.4)	1.3 (4.9)	4 (15.1)
48" Top & Bottom Fill (3" Screen)	48 (122)	3 (7.6)	59 (149.9)	16.5 (7.5)	1.3 (4.9)	4 (15.1)
48" Top & Bottom Fill (12" Screen)	48 (122)	12 (30.5)	68 (172.7)	18.0 (8.2)	1.3 (4.9)	4 (15.1)

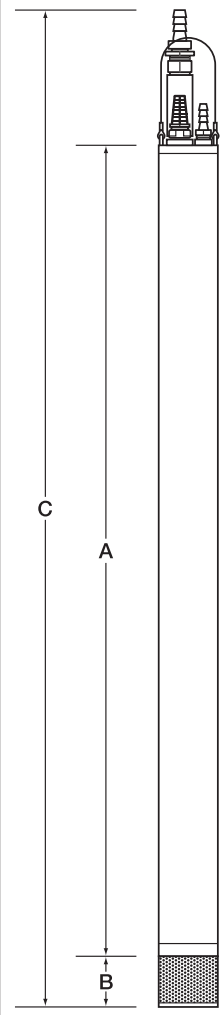

NOTES

Chapter 7: Replacement Parts List

Item	Qty	Description	Part No.
1	1	HOSEBARB, SS6, 3/4 x 3/4 MPT	16600218
2	1	BUSHING, SS4, 1" x .75"	PPP012052
3	1	BUSHING, SS4, ORBITAL, DISCH 3.5	26600196
4	1	BALL, SS, 7/8"	17500207
5	1	BODY, SS4, DISCHARGE, 3.5 AUTO	26600169
6	1	HOSEBARB, SS6, 1/2 x 3/8 MPT	16600217
7	1	SCREEN, INTAKE, PVC, 3.5 AUTO	16600211
8	1	BUSHING, SS4, INTAKE, 3.5	26600152
9	1	BALL, PTFE, 7/8"	16600098
10	1	PLUG, SS4, 1" NPT, SCK HEX	16600156
11	1	HEAD, RECLAIMER, 3.5	26600212
12	1	O-RING, VITON, #336, SHORE75A	17500516
13	1	PIPE, CENTER, SS4, 3/4 x 24, 3.5 RECLAIMER	26600211
	1	PIPE, CENTER, SS4, 3/4 x 36, 3.5 RECLAIMER	26600218
	1	PIPE, CENTER, SS4, 3/4 x 48, 3.5 RECLAIMER	26600219
14	1	HOUSING, 3.5 RECLAIMER, 24"	56600062
	1	HOUSING, 3.5 AR/RECLAIMER, 36"	56600032
	1	HOUSING, 3.5 AR/RECLAIMER, 48"	56600030
15	1	CAP, BOTTOM INLET, 3.5	26600040
16	1	BOTTOM INLET, SS, 3.5	26600039
17	1	PIN, DOWEL, SS6, 1/2 x 2.80"	16600102
18	1	BALL, TFE, 1.5"	17500315
19	1	CAP, BOTTOM BLANK, SS, 3.5	26600042
20	1	SCREEN, INLET, SS, 3.5, FLAT	26600131
21	3	SCREW, SS8, 1/4-20 x 3/8, SHCS	16600166
22	1	SCREEN, INLET, SS, 3.5 x 3"	26600049
23	1	CAP, BOTTOM INLET SCREEN, 3.5	26600032
24	3	SCREW, SS8, 1/4-20 x 3.5", SHCS	16600091
25	1	SCREEN, INLET, SS, 3.5 x 12"	26600146
26	3	ROD, SS8, THD, 1/4-20 x 12.813	26600147
27	3	NUT, HEX, SST, 1/4-20	PPF011002
28	1	MANUAL, RECLAIMER 3.5	26600223

System Components

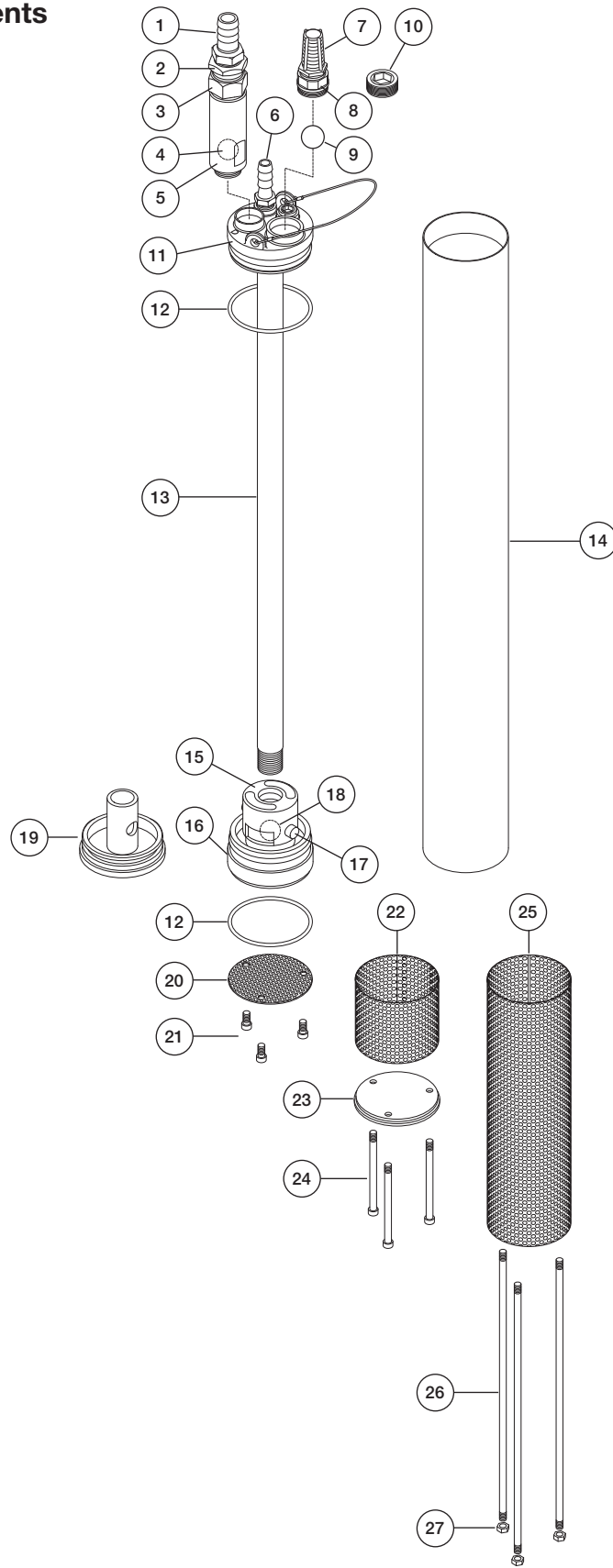

Figure 5

THE WARRANTY

For a period of one (1) year from date of first sale, product is warranted to be free from defects in materials and workmanship. Geotech agrees to repair or replace, at Geotech's option, the portion proving defective, or at our option to refund the purchase price thereof. Geotech will have no warranty obligation if the product is subjected to abnormal operating conditions, accident, abuse, misuse, unauthorized modification, alteration, repair, or replacement of wear parts. User assumes all other risk, if any, including the risk of injury, loss, or damage, direct or consequential, arising out of the use, misuse, or inability to use this product. User agrees to use, maintain and install product in accordance with recommendations and instructions. User is responsible for transportation charges connected to the repair or replacement of product under this warranty.

Equipment Return Policy

A Return Material Authorization number (RMA #) is required prior to return of any equipment to our facilities, please call 800 number for appropriate location. An RMA # will be issued upon receipt of your request to return equipment, which should include reasons for the return. Your return shipment to us must have this RMA # clearly marked on the outside of the package. Proof of date of purchase is required for processing of all warranty requests.

This policy applies to both equipment sales and repair orders.

FOR A RETURN MATERIAL AUTHORIZATION, PLEASE CALL OUR SERVICE DEPARTMENT AT
1-800-833-7958

Model Number: _____

Serial Number: _____

Date of Purchase: _____

Equipment Decontamination

Prior to return, all equipment must be thoroughly cleaned and decontaminated. Please make note on RMA form, the use of equipment, contaminants equipment was exposed to, and decontamination solutions/methods used.

Geotech reserves the right to refuse any equipment not properly decontaminated. Geotech may also choose to decontaminate equipment for a fee, which will be applied to the repair order invoice

Geotech Environmental Equipment, Inc.
2650 East 40th Avenue • Denver, Colorado 80205
(303) 320-4764 • **(800) 833-7958** • FAX (303) 322-7242
email: sales@geotechenv.com website: www.geotechenv.com