

Gas & Flame Detection



- Analog and digital controller
- 4 or 8 lines / 16 to 32 detectors max
- Highly versatile controller
- SIL 1 reliability

3M™ Oldham MX 43

Controller

CONTROLLER PRESENTATION

The MX 43 is an analog and digital controller designed for the continuous measurement and control of the gases present in the atmosphere and for 4-20 mA or digital contact signal.

Large graphic display

Smart keys make embedded menus simple to use



Front panel LEDs allow a quick and basic overview of the installation.

MX 43 manages both digital lines and analog channels, and covers all needs for a wide variety of applications.

The MX 43 digital technology allows up to 32 detectors to be distributed on 8 lines for increased cost savings.

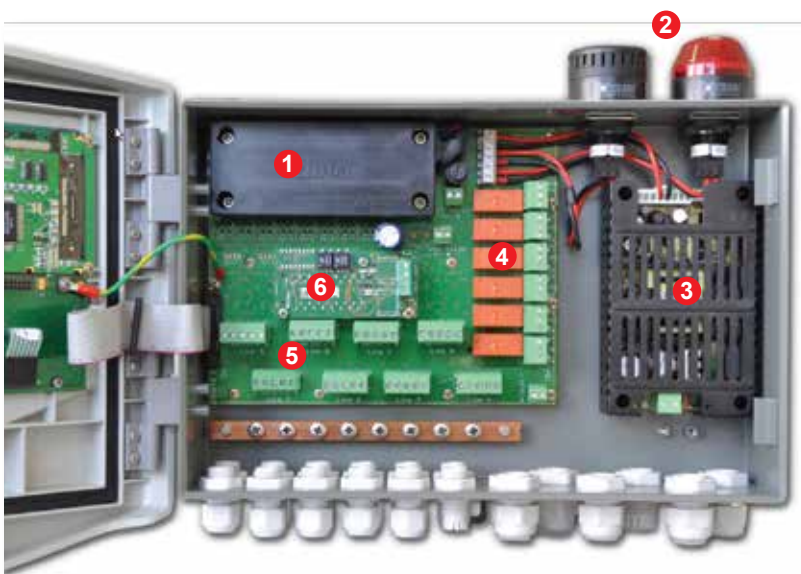

- 1 Back-up battery
- 2 Strobe and horn
- 3 Power supply
- 4 On-board relays
- 5 Removable terminals
- 6 RS485 output
- 7 USB datalogging kit



NORMAL MODE

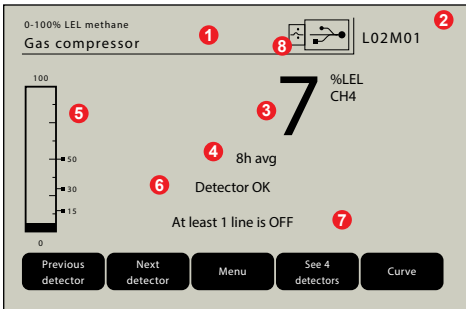

- 1 Measurement range, gas and detector tag
- 2 Detector address
- 3 Current value with unit and detected gas
- 4 Averaged value on the last 8 hours
- 5 Bar graph with alarm thresholds
- 6 Detector status (OK, OFF, fault)
- 7 MX 43 status information
- 8 Records on progress

CALIBRATION CURVE

Simplified procedure that enables time savings (i.e. non-intrusive and one-man calibration).

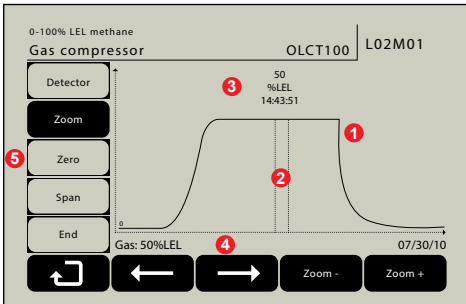

- 1 Calibration curve
- 2 Cursors for span settings
- 3 Measured value
- 4 Calibration gas value
- 5 Detector selection, zeroing and spanning

ALARM MODE

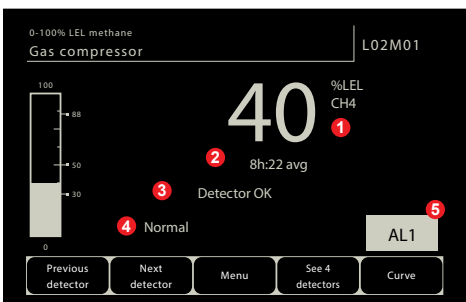

Reverse video in alarm conditions for immediate identification of the concerned detector.

- 1 Current value with unit and detected gas
- 2 Averaged value on the last 8 hours
- 3 Detector status (OK, OFF, fault)
- 4 MX 43 status information
- 5 Detector in alarm

IN 4-CHANNEL DISPLAY

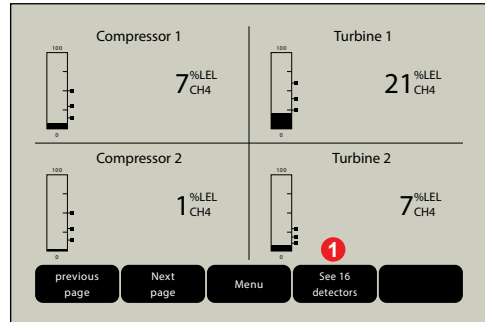

- 1 Up to 16 detectors can be displayed simultaneously

DATA-LOGGING

By default, the MX 43 can store up to 512 alarm events, 512 fault events and 512 system events.

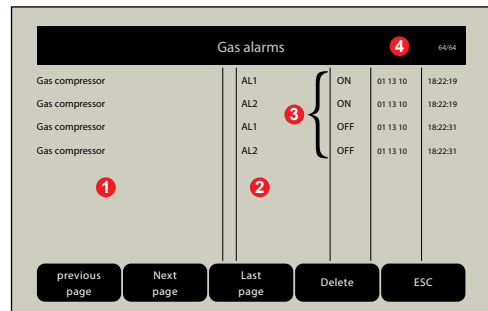

- 1 Detector tag
- 2 Event
- 3 Date and time of events appearance or clearance
- 4 Page number (up to 64 pages)



The USB option enables gas measurements to be saved at a sampling rate of 2 seconds to 15 minutes while events are saved when they happen.

The 4 Gb USB drive provides more than 2 years of storage in most of configurations. The USB option also delivers the ability to save and restore configuration and firmware files.

COM 43 CONFIGURATION SOFTWARE

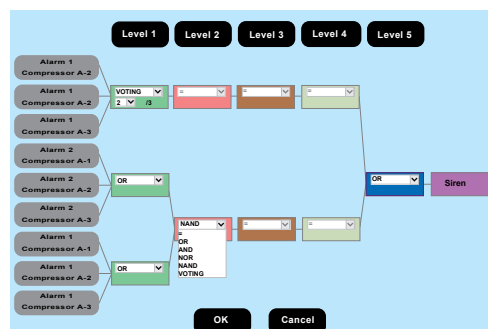

- 1 Simple relay programming
- 2 Up to 5 embedded functions: OR, AND, NOR, NAND, VOTING
- 3 Several timers available
- 4 Advanced management of audible alarms (acknowledgment, reactivation, evacuation)

3M™ Oldham MX 43

Controller

MODULES

Different modules can be connected to the controller:

4 OR 8-RELAY MODULE



4 or 8-programmable-relay module can be located closer to the actuators for cost savings.

16-LOGIC-INPUT MODULE



Addressable module of 16 logic input for recovery of digital information such as fire or intrusion alarms, emergency stop, limit switch activation, etc.

8-ANALOG-INPUT MODULE



This module enables standard analog transmitters (gas or flame detectors for instance) to be connected on a digital line for cost savings.

4-ANALOG-OUTPUT MODULE



Addressable 4- analog output module which delivers 4 analog 4-20mA signal outputs (detector output copy, min, max, average of a group of detectors) for connection to a datalogger, a PLC, a building Management System (BMS), etc.

CONFIGURATION EXAMPLE

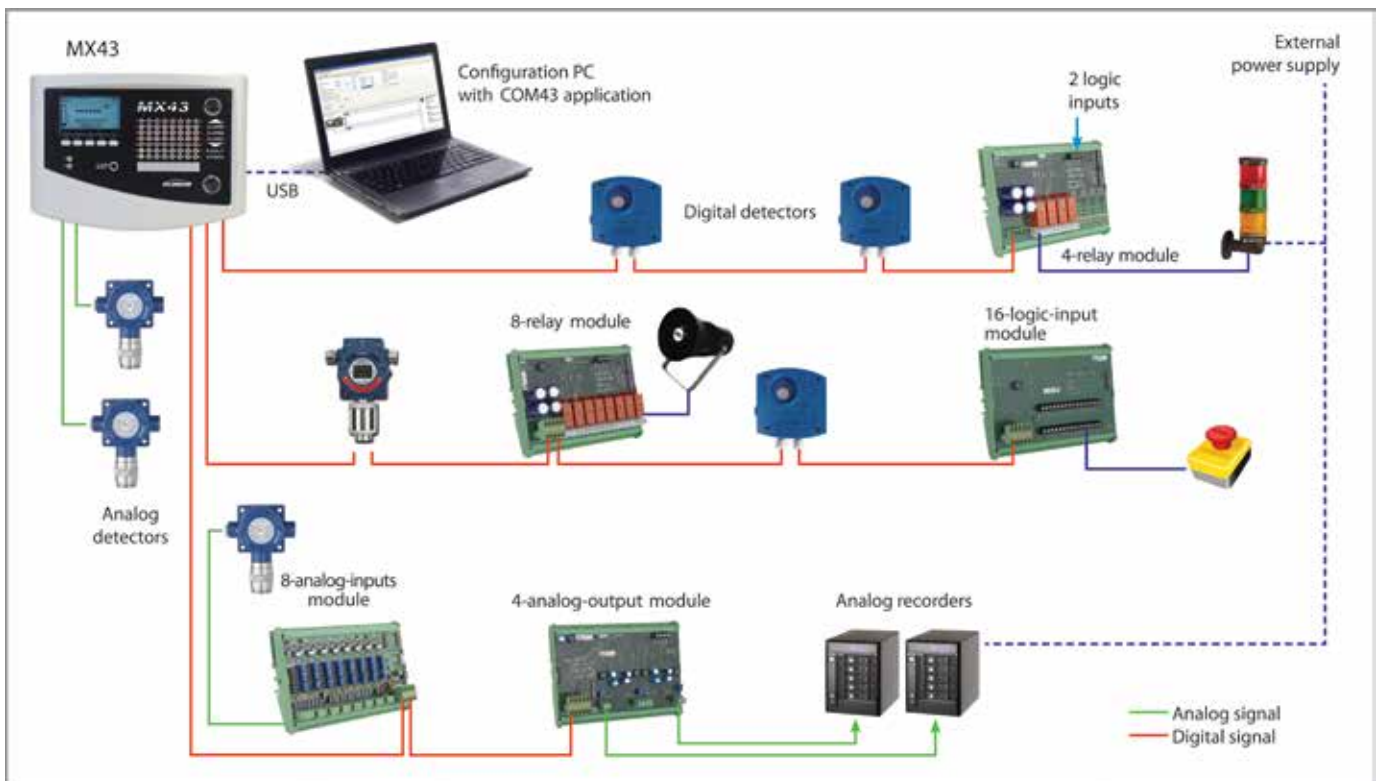

| Model | MX 43 gas detection control panel |
|--------------------------------------|--|
| Dimensions (wall-mounted version) | 370 × 299 × 109 mm (14.6 × 11.8 × 4.3 inches) |
| Dimensions (rack) | 19", 4U ; 482.8 × 177 × 192.5 mm (19.1 × 7 × 7.6 inches) |
| Ingress protection | IP55 (wall-mounted), IP31 (rack) |
| Cable entries (wall-mounted version) | 12 M16 cable glands, 4 to 8 mm ² (8 to 11 AWG) outer diameter cable 6 M20 cable glands, 6 to 12 mm ² (7 to 9 AWG) outer diameter cable |
| Display | LCD back-lit display + smart keys Display in video inverse in case of fault Customizable by user (display 1 to 16 channels simultaneously, fixed or scrolling, on events...) Bar graph with alarm threshold |
| Visual indicators | 7 LEDs per line for detector status 1 common LED for Fault condition 1 common LED for Power indicator |
| Buttons | 5 smart keys 1 audible alarm accept/reset button |
| Operating use | |
| Operating temperature | -20°C to +50°C |
| Storage temperature | -20°C to +50°C |
| Humidity | 5 to 95% RH |
| Power | 100-240 Vac 50-60 Hz or 21-28 Vdc, 112 W max |
| Battery | Embedded back up power supply in option (0.6 Ah) |
| Consumption | 500 mA min (without module) |
| Measurement lines | |
| Digital lines | 8 maximum RS-485 communication, proprietary protocol, 9600 Baud 2 twisted shielded-pair cable |
| Analog channels | 8 maximum 0-23 mA analog signal input (4 to 20 mA reserved for measurement) 120 Ohm load resistance 2 or 3-core shielded cable |
| Voltage (typical) | 21 to 28Vdc |
| Maximum current output per line | 1.2 A (1.5 A intermittently) |
| Maximum current output in total | 2.4 A permanent (3.2 A intermittently) |
| Alarms | |
| Per channel | 5 alarm levels (A1, A2, A3, Overscale, Underscale) + Fault Non-ambiguity reading option for combustible gases monitoring |
| Programmable thresholds | On instantaneous or averaged values, rising or falling alarms, manual or automatic acknowledgement |
| On-board relays | 5 fully programmable alarm relays 1 fault relay (non-configurable) Dry contact relay DPCO relays with contact rating of 250 Vca 2 A (inductive) |
| Digital outputs | RS-485 Modbus RTU serial link |
| Approvals | |
| EMC | According to EN50270 |
| ATEX | EN50271 and metrological performances according to EN60079-29-1 |
| Low Voltage Directive | According to EN61010 |
| CSA | Pending |
| Functional safety (Reliability data) | SIL1 capability according to EN50271:2010 du =2,29.10 ⁻⁶ , PFDavg=1,03.10 ⁻² , Ti=1 year, MTBF=20 years, SFF 60% (data for 4 channel version, 24 Vdc powered) |
| MED | According to Marine Equipment Directive 96/98/EC. Fulfills the EMC requirements for installation in General Power Distribution Zone and/or Deck Zone. |

3M™ Oldham MX 43

Controller

OUR FIXED DETECTOR RANGE



OLCT 10



OLCT 10N



CTX 300



OLCT 100



iTrans 2



OLCT 80



OLCT 60



OLCT 60 / OLCT IR



OLCT IR



Meridian



Spyglass



Flamevision

3M

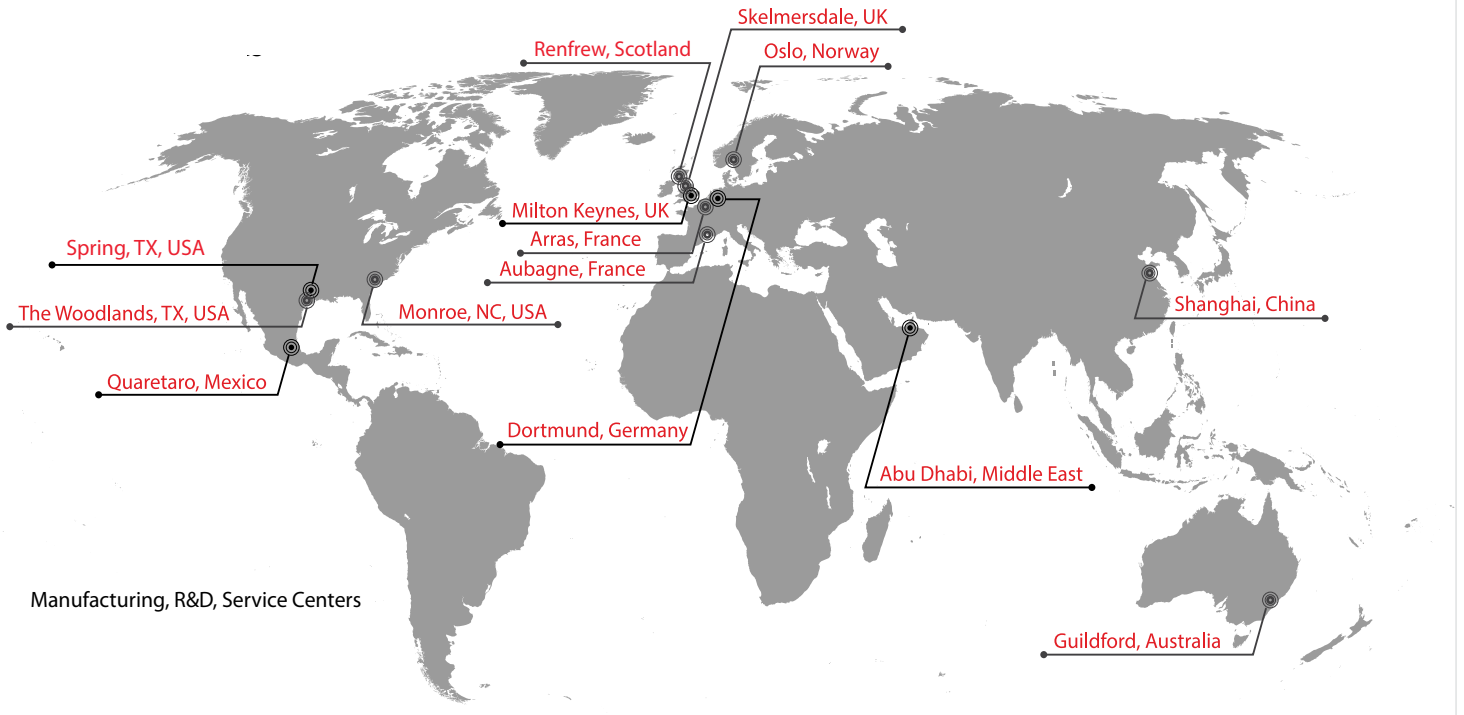

As an ISO 9001 & ISO 14001 approved company, OLDHAM quality assurance programmes demand the continuous assessment and improvement of all OLDHAM products. Information in this leaflet could thus change without notification and does not constitute a product specification. Please contact OLDHAM or their representative if you require more details.

AMERICAS - Texas (USA)

4055 Technology Forest Blvd.
The Woodlands, TX 77381
Tel.: +1-800-247-7257
Fax: +1-281-292-2860

EMEA

ZI Est, Rue Orfila,
CS 20417
62027 ARRAS CEDEX, France
Tel.: +33-3-21-60-80-80
Fax: +33-3-21-60-80-00

ASIA PACIFIC

290 Guiqiao Road
Pudong, Shanghai 201206
People's Republic of China
Tel.: +86-21-3127-6373
Fax: +86-21-3127-6365

3M

Copyright © 2018 3M, 3M Gas & Flame Detection. All rights reserved.
gasdetection.3m.com. GF-30005C-EN