

# HALOGUARD® IR

## MULTI-POINT, COMPOUND SPECIFIC MONITOR

### INSTRUCTION MANUAL

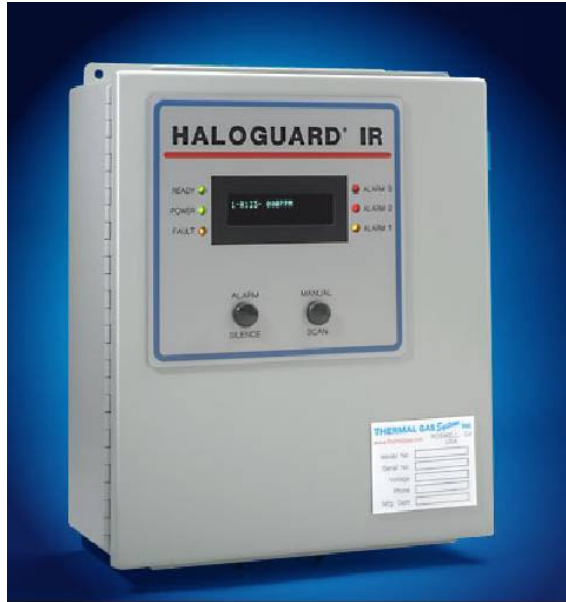

SERIAL NO. \_\_\_\_\_

MODEL NO. \_\_\_\_\_

**Temp. Range**

- 1 - = > 60°F
- 2 - = 40 - 60°F
- 3 - = < 40°F

**Gas Type**

- 1 - R-11
- 2 - R-12
- 3 - R-22
- 4 - R-134a
- 5 - R-113
- 6 - NH3
- 7 - R-123

**Range**  
0-1000ppm

**Outputs**

- 1 - 4 x 5 A Relays
- 2 - 0 - 5/10 VDC
- 3 - 4 - 20mA
- 4 - Add 3 x 5 A Relays
- 5 - RS232/485

**Options/Accessories**

- A - Audible Alarm
- B - Battery B/U-UPS
- E - Inlet/Outlet Extension
- H - Oxygen Sensor 0-25%
- L - Strobe Light
- S - Scanner (2, 4, or 8 pt.)
- R - Remote Expansion Module

## THERMAL GAS *Systems* inc.

11285 Elkins Road, Bldg. H-1  
Roswell, GA 30076  
TEL: 770-667-3865  
FAX: 770-667-3857  
[www.thermalgas.com](http://www.thermalgas.com)

---

**\*\*\*\*IMPORTANT\*\*\*\***

**USER TO READ, FULLY UNDERSTAND AND FOLLOW ALL INSTRUCTIONS PROVIDED BY THE MANUFACTURER FOR INSTALLATION AND OPERATION OF THE HALOGUARDIR MONITOR. FAILURE TO DO SO COULD RESULT IN HARM.**

---

**TABLE OF CONTENTS**

	<u>Page</u>
1. Unpacking Instructions-----	3
2. Before Installation-----	3
3. Function of LED's, Pushbuttons, & LCD Information-----	4
4. Installation-----	6
5. Set-up & System Configuration-----	8
6. Calibration, Testing, & Trouble Shooting-----	10
7. Maintenance & Specifications-----	11

**FIGURES & APPENDICES**

	<u>Page</u>
1. Typical Area Monitoring Installation-----	3
2. Mounting Dimensions-----	4
3. LCD Display Information-----	4
4. Haloguard IR-----	5
5. Analog Jumper Settings-----	6
6. Circuit Board-----	7
7. Setup & Configuration Jumper Settings-----	8
8. Remote Expansion Module Terminations-----	9
9. Remote Expansion Module Circuit Board-----	9
10. Replacement Parts-----	11
11. Accessories-----	11
12. Initial Factory Settings-----	11
13. Refrigerant Exposure limits-----	11
14. Wiring Diagram-----	12
15. APPENDIX A - Analog Output Data Translation-----	13

## UNPACKING INSTRUCTIONS

Haloguard monitors are carefully packed, inspected and delivered to the carrier in good condition. If damage occurs in transit it is the responsibility of the carrier. Carefully inspect the unit upon receipt. **Any damage should be reported to the carrier and an inspection requested.** After inspection by the carrier and your receipt of his acknowledgment as to the damage, contact us for return authorization (RMA). We cannot file claims for damaged goods on your behalf, but we will assist you in any way we can. In order to expedite our work, please provide serial number and model number when you call.

---

**WE CANNOT ACCEPT RETURNS WITHOUT PRIOR APPROVAL.**

---

### BEFORE INSTALLATION

1. Remove Haloguard IR from carton. Check contents against packing list. If shipment is incomplete, contact us immediately.
2. Select a site for the installation:
  - a. Power requirements: Provide a clean source of power 115-230 VAC, 50/60 Hz, single-phase 15A minimum. *AC Line conditioning equipment may be necessary in some locations.*
  - b. Sample tube pick-up should be located near potential leaks in a quiet area or downstream from leak source in area with air movement.
  - c. Sample tube pick-up should be located 18" - 24" above the floor. If using optional scanner, locate sample tubes at points near all chiller locations. Make sure each sample tube is equipped with an end of line filter.
  - d. Make sure the area selected is not subject to flooding, potential impact or severe ambient temperature and humidity changes (i.e. boiler blow-down or near roll-up doors).
  - e. Narrow band infrared detector is highly selective but may respond to the presence of other refrigerants if interfering gas reaches a very high concentration. For accurate leak detection select a location free from interfering vapors. Contact us for specific gas interference.
3. The Haloguard IR should be installed indoors, about five feet (eye level) above the floor and at a location easily visible to operators, in an area with minimal vibration, and with temperature and humidity changes like sample pick-up location. **DO NOT MOUNT DIRECTLY TO CHILLER.**

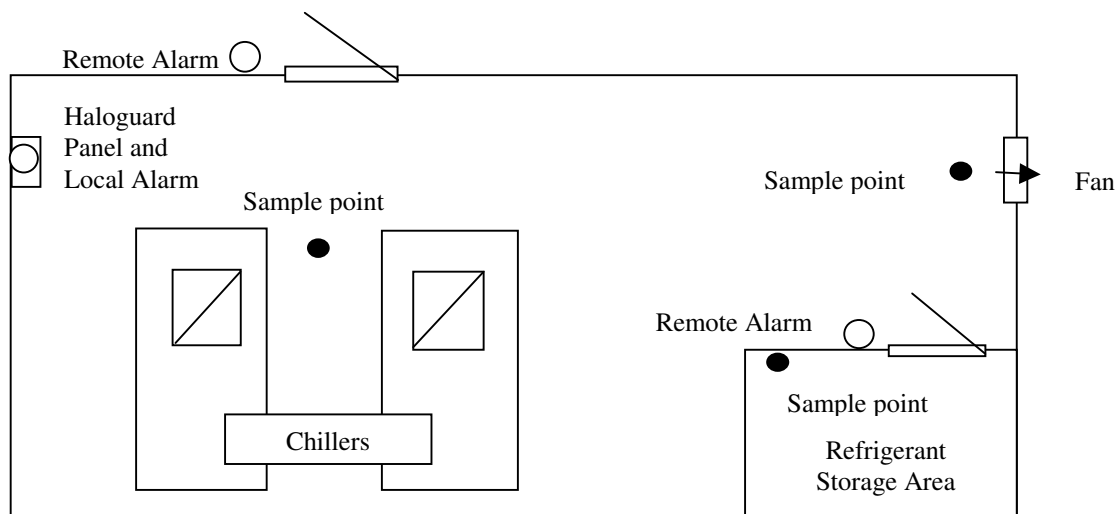

**Fig. 1-Typical Area Monitoring Installation**

**IMPORTANT**  
**CONSULT LOCAL AND NATIONAL ELECTRICAL CODES FOR ANY SPECIAL**  
**REQUIREMENTS OR RESTRICTIONS BEFORE INSTALLING HALOGUARD**

**FUNCTION OF LED'S, PUSHBUTTONS, and LCD DISPLAY INFORMATION**

1. **READY LED** - Steady LED means Haloguard IR is measuring ppm; blinking indicates otherwise.
2. **POWER LED** - Green LED indicates Haloguard IR is receiving power.
3. **FAULT LED** – LED indicates malfunction. LCD indicates specific type of failure (See Figure 3)
4. **ALARM 1, ALARM 2, ALARM 3 LED's**-Adjustable Alarm levels & relays - Factory set for particular refrigerant (See Figure 12 ). User adjustable as follows:

MEASURMENT RANGE	1 PPM INCREMENTS	10 PPM INCREMENTS
0 - 1000 ppm	10 – 100 ppm	100 – 1000 ppm

5. **MANUAL SCAN** push-button – Allows manual scan of last ppm reading for all channels.
6. **RESET/SILENCE** push-button - Silences alarms, disables relays, and resets instrument for 20 minutes. LCD displays RESET/SILENCE with 20-minute countdown. Alarms are automatically reactivated if alarm condition is not corrected. Reset is automatically initiated on start-up and after power failure.
7. **Optional Display Features: TWA Integration** – Haloguard IR calculates an 8-hr. Time Weighted Average (TLV-TWA), displays this value on LCD, activates Alarm 1 LED and relay if factory set PPM value is exceeded. Used for gases with TLV-TWA less than 1000ppm. TLV-TWA Alarm is factory set at 50ppm and is not user adjustable.

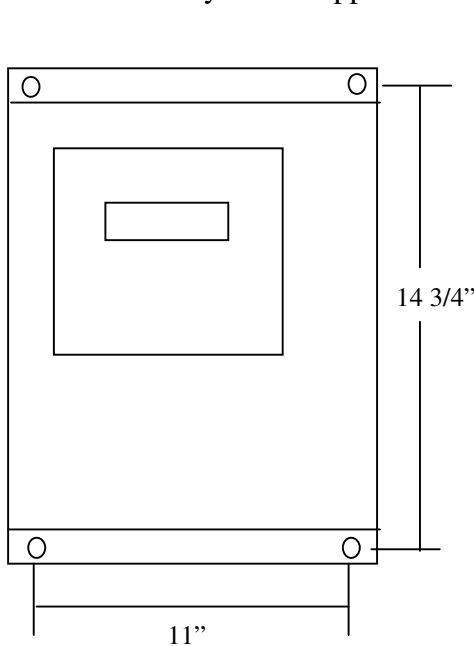

**Fig. 2- Mounting Dimensions**

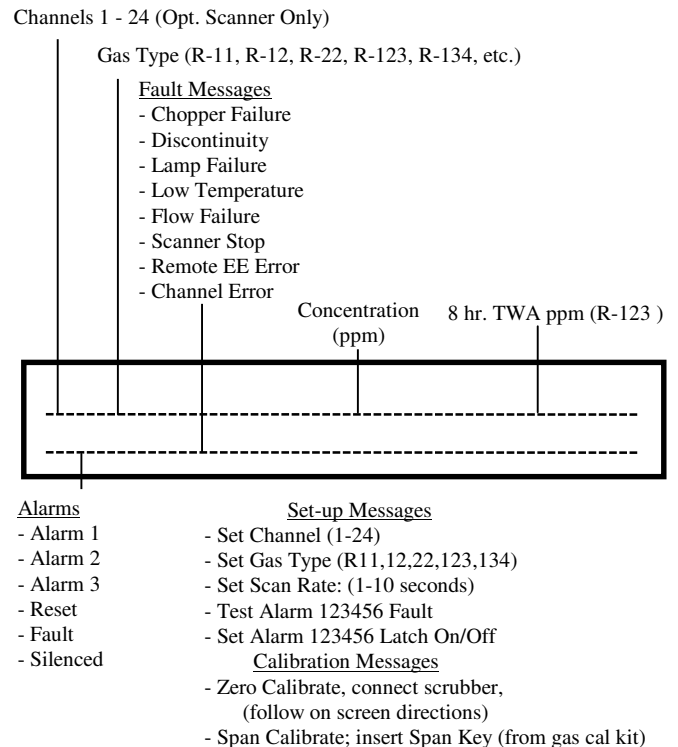

**Figure 3 - LCD Display Features**

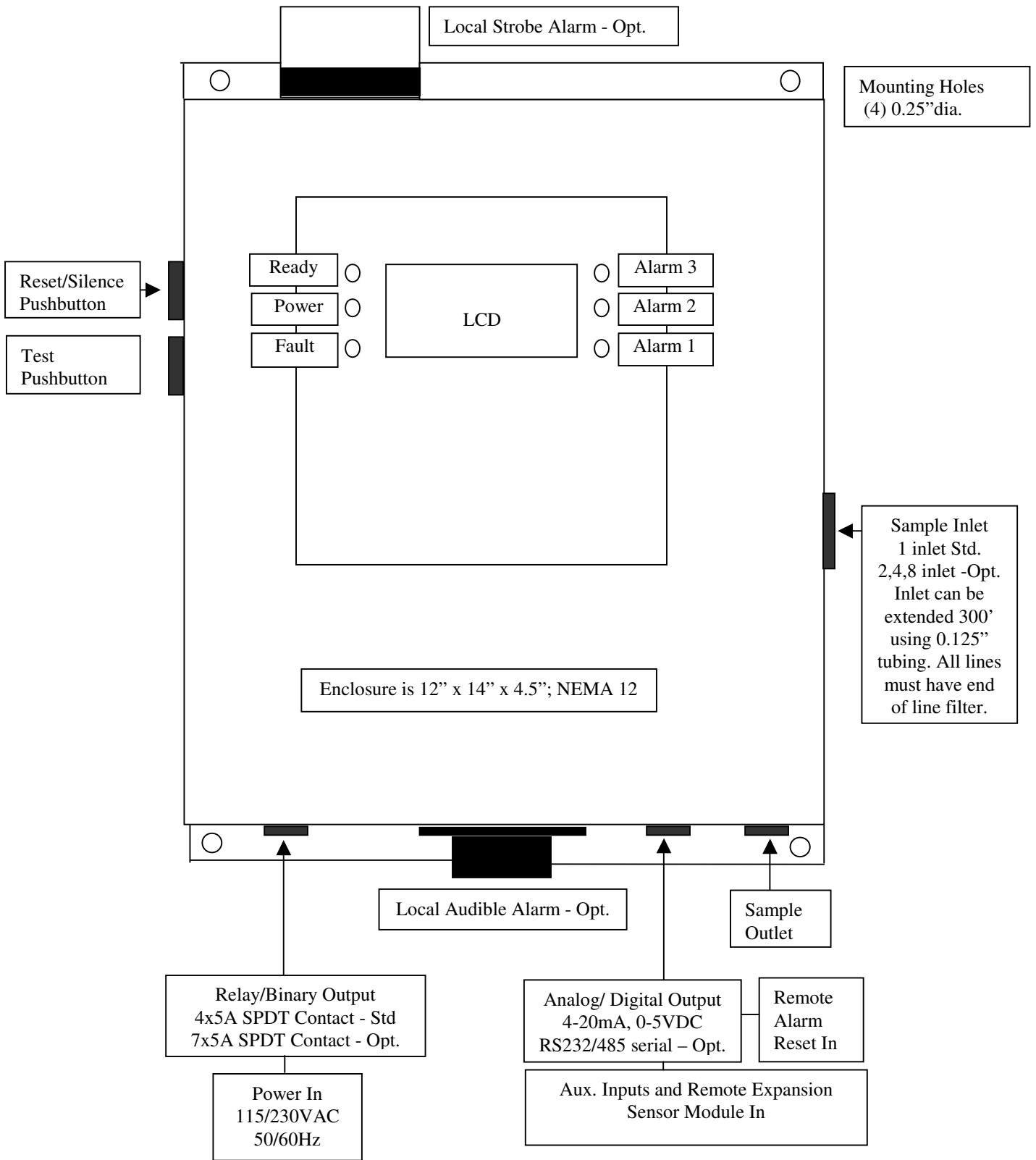

**Fig. 4-Haloguard IR Layout**

## INSTALLATION

1. Check power supply and determine best location. (See Section “Before Installation”)
2. Disconnect power before beginning.

---

**Refer to figures 2, 3, 4, 5, 6, and 14 before proceeding.**

---

### 3. Installation

#### a. Mounting Haloguard IR

1. Securely mount the unit to a wall or support using the (4) mounting holes.
2. Remove cover.
3. Install sample tube to 18-24” above floor, install end of line filter. Sample inlet may be extended up to 300FT with 0.125” OD x 0.093” ID nylon, copper or stainless steel tubing. When extending sample tubing:
  - a. Keep sample lines as short as possible and free of kinks.
  - b. Exhaust to atmosphere. **DO NOT** install any device that might restrict the flow.
4. Route sample inlet tubing through entry indicated (Figure 4 ) and insert into one-touch fitting provided. To remove tubing, pull plastic ring on end of one-touch fitting to release.

#### b. Wiring Connections:

1. Relay Terminals – Route wire through entry indicated. (Figure 4). Remove safety cover. Connect alarm relays **NO or NC** (Figure 6) required.
2. Power Supply Wiring - Route wire through entry indicated. (Figure 4). Remove safety cover. All connections are made to the terminal block labeled IN 120/250VAC (Figure 6). Connect HOT AC wire to Terminal L. Connect NEUTRAL wire to terminal N. Connect a GROUND wire to terminal G. Auxiliary 120/250VAC output is provided to power remote audible and strobe light alarms. This output is not fused. Limit load to 0.5A.max total. Replace cover.

**\*\*WARNING\*\* analog output is a driven signal, do not connect any wire with voltage or current to analog output terminals**

3. Analog Output (Optional) – Two analog outputs are provided for connection to remote recording devices; PPM ANALOG OUTPUT is for gas concentration; CHANNEL ANALOG OUTPUT is for channel location (Figure 14). See Appendix 1 for analog output translation data. Connect 18 gage twisted shielded pair as follows, maximum length 300 ft.:

Analog Output Range	Terminal Position
0-10VDC	V and GND
4 - 20mA	I and GND

**Figure 5 - Analog Output Terminal Block Settings**

4. External Input (VDC) – Five analog inputs (EXT INPUT 1-5) are provided for connection of remote input devices such as oxygen sensors, CO sensors, and flammables sensors (Figure 6).
5. Remote Input (mA) – Two analog inputs (REMOTE IR INPUT 1 & 2) are provided for connection of Haloguard Remote Expansion Module (Figure 6). Each terminal block has connections for both Remote channel and PPM inputs.
6. Uninterruptible Power Supply (Optional) – Make sure UPS is fully charged. Plug UPS into power supply, turn switch ON. Connect Haloguard IR to UPS, with power cord provided.

- c. On power-up, **RESET/SILENCE** and 20 minute count down will appear on LCD. For 20 minutes after power up all alarms and relays are automatically disabled. Whenever power is disrupted, **RESET/SILENCE** mode will be automatic (unless optional UPS is supplied) to protect against false alarms. Allow 1 hour for warm-up from cold start.

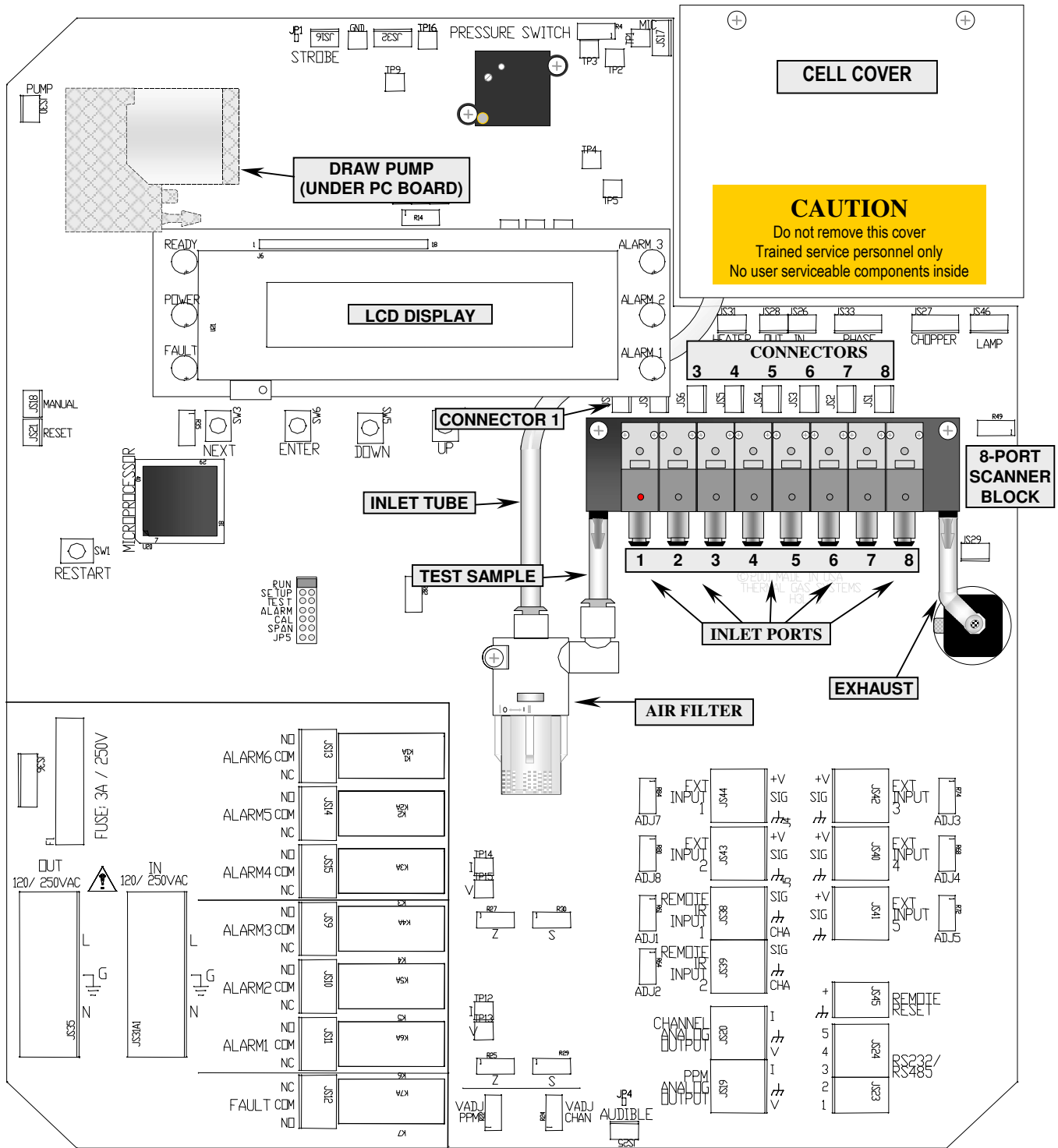

**Figure 6 - Circuit Board**  
(Shown with Optional 8 Point Scanner)

## SETUP and SYSTEM CONFIGURATION

Locate configuration jumpers on Figure 6. Select configuration settings from the following:

<b>JP</b>	<b>FUNCTION</b>
<b>RUN</b>	Select run for normal operation
<b>SETUP</b>	Set gas type and number of active channels
<b>TEST</b>	Sequentially activates all Alarm & Fault LED's & relays
<b>ALARM</b>	Set-point Adjustment for Alarm 1, 2, and 3. Latch ON/OFF
<b>CAL</b>	Zero Calibration
<b>SPAN</b>	For use only with span gas and key
<b>JP5</b>	Factory only

**Figure 7 – Setup & Configuration Jumper Settings**

1. **RUN** - Normal operation jumper position. Replace jumper when finished other modes.
2. **SETUP** - Gas types and number of active channels will be preset at the factory (Figure 12). To change gas type or activate a channel, first select the channel to activate with cursor using the UP and DOWN pushbuttons. Press ENTER then use the same pushbuttons to select the gas type for each channel. Be sure to press ENTER to select. “NONE” selected in the gas type menu will deactivate the channel.
3. **TEST**- Select alarm to test with cursor by using the UP, DOWN, and ENTER pushbuttons.
4. **ALARM** - Alarm levels will be preset at the factory (Figure 12). Select the ALARM to adjust with the cursor using the UP, DOWN, and ENTER pushbuttons. Use the same pushbuttons to change the alarm PPM set point. “OFF” selected turns alarm off.
5. **CAL** – Install optional activated charcoal filter in channel 1; follow on screen directions to zero calibrate using the ENTER pushbutton.
6. **SPAN** –Key and instructions for use are included with Span Gas Calibration Kit
7. **JP5**- Factory only.

### System Configuration:

1. Relay Latch Setup - Factory recommended setting is unlatched mode; e.g., the alarm LED's and relays will return to a normal status when gas concentration goes below alarm set-point. To select latched mode place jumper on **ALARM** setting. Select LATCH mode with the cursor using the UP, DOWN, and ENTER pushbuttons. LATCH ON appears on the LCD Display. Latched mode requires manual RESET for all alarms
2. Analog Output (optional) is factory set at 0-5VDC or 4-20mA as ordered. Use Analog trim pot (Figure 6) to adjust voltage for up to 0-10VDC range
3. LCD display adjustment potentiometer changes brightness (Figure 6).
4. Two, Four or Eight Point Scanner - (Optional) Scanner is factory installed. Scanner automatically sequences through each port (1-2, 1-4 or 1-8).
  - a. Manual Scan - While in RUN Mode,
    1. Press MAN SCAN button on side of controller. Each time the button is pressed, display will advance to next sample point. Controller will return to automatic sequencing within 2 minutes.
    2. Adjust Scan Display Rate - Rate is factory set at 4 seconds per point. Rate is adjustable from 1-10 seconds. To change scan display rate press ENTER from RUN mode; adjust using UP and DOWN; press ENTER to return to RUN mode.



## INSTALLATION OF OPTIONAL REMOTE IR EXPANSION MODULE

**Refer to FIGURE 4, 6, 8, 9 and 14 before proceeding.**

**DO NOT CUT SUPPLIED CABLE**

Controller is provided with 18” cable with DIN connector and expansion module is provided with 6-1/2’ cable. If cable extension is required we recommend 3-conductor, 18-gage cable with foil shield, Carol C2535 or equal. Use 3/4” conduit if required. Maximum 1000 ft. length

Remove 18” cable with DIN connector from controller circuit board terminal block marked REMOTE INPUT 1(or REMOTE INPUT 2). Splice or solder extension cable to end of 18” cable. Reconnect extended sensor cable to terminal block on circuit board of controller.

Terminal	18” cable Wire Color	Extension Wire Color	Remote Function
<b>CHA</b>	Red	Red	Scanner
<b>SIG</b>	White	White	Signal
<b>GND</b>	Blk/Blk	Black	Ground

Note - CHA Terminal is used for expansion modules with scanner only.

**Figure 8 – Remote Expansion Module Terminal Connection**

**To avoid nuisance alarms remove “AUD” alarm jumper in Haloguard IR before beginning.**

To compensate for line losses adjust signal voltage with a digital VOM as follows:

1. Open cover on Remote IR expansion module. Move jumper from RUN to SETUP. **Wait approximately 1 minute before proceeding.** (Display of Haloguard IR shows SETUP.)
2. Open cover on Haloguard IR Controller.
3. With VOM on 5 VDC scale, place VOM probe on SIG (+) and GND (-) Test points on Haloguard IR Main Board (Figure 6). **Adjust ADJ1 or ADJ2 potentiometer with screwdriver until it reads 4.975 +/- 0.025 VDC.**
4. If Remote expansion module is provided with scanner, lock the scanner on channel 1 using the jumper provided (Figure 9) on the Scanner Circuit Board. With VOM on 5 VDC scale, place VOM probe on CHA (+) and GND (-) Test points on Haloguard IR Main Board (see Figure 6). **Adjust ADJ4 or ADJ5 potentiometer with screwdriver until it reads 1.0 +/- 0.05 VDC.**
5. Move scanner channel jumper in expansion module back to its original position.
6. Move jumper in expansion module back to RUN. Replace AUD jumper in Haloguard™ III.

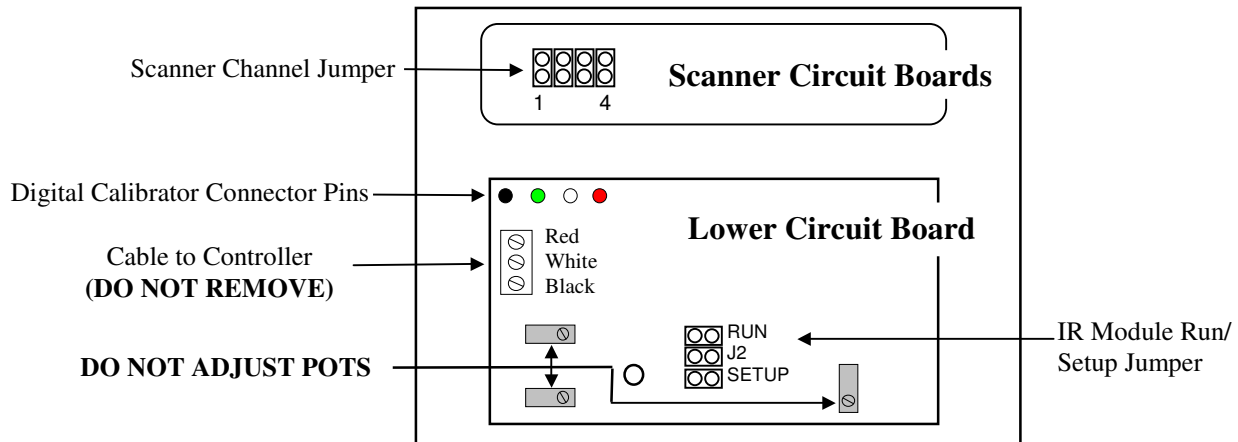

**Figure 9 - Expansion Module Circuit Board**

## **CALIBRATION**

Haloguard IR monitors are factory calibrated to the specific gas of interest. Field calibration is not required for operation in typical machine room environments during the first twelve months of operation unless a change in gas type is required.

For those who wish to check the factory calibration or change the gas type an optional Span Gas Kit is available. Instructions for use are included with kit

## **TESTING**

The Haloguard IR should be tested at start-up, after any changes to alarm protocol, and after each alarm level condition has been corrected. During testing, display will indicate ALARM TEST

- a. Alarm Test – Enter TEST mode with jumper, select alarm with cursor by using the UP, DOWN, and ENTER pushbuttons. Check all alarms sequentially. Alarm relays, lights, audible, analog outputs, and remote alarms (if equipped) will activate if selected.
- b. Reset Test - Push RESET/SILENCE button; alarm relays, audible and remote alarms (if equipped) will become inactive for 20 minutes. Display will read RESET/SILENCE and indicate minutes to completion of reset period.

## **TROUBLESHOOTING**

The most frequent cause of nuisance alarms and fault is improper set-up, primarily due to:

- a. Failure to install in accordance with instructions.
- b. Not allowing sufficient warm-up time.
- c. Poor sensor location.

To check Zero Calibration, fill a clean plastic trash bag with clean outside air, tie off with twist-tie, let sample stabilize inside for 15 - 20 minutes. Insert sample tube into bag. For models equipped with scanner allow up to 2.5 minutes per channel for clean air sample analysis.

Observe LCD response, if displayed PPM value changes to near 0 PPM, the Haloguard IR is detecting the presence of the gas of interest or another gas in the room which absorbs infrared light at the same frequency.

Remove sample tube from bag and observe LCD response. If displayed PPM value moves higher, look for refrigerant leaks or possible sources of interfering gases (See “Before Installation”) and relocate sample point.. Keep in mind that the Haloguard IR is much more sensitive than hand held leak detectors, it may detect a leak when hand held units show no response.

We wish to aid with any problems you might experience with the Haloguard IR. When contacting Thermal Gas Systems, Inc. Service Department, please have the following information ready.

1. Model Number and Serial Number.
2. Description of the problem.
3. Remove cover. Place RUN jumper on ALARM and record settings. Place jumper on SETUP and record settings. Place jumper on JP5 and record settings.
4. Advise the condition of all LED's and the information displayed on the LCD.

## MAINTENANCE

There is no scheduled maintenance for the first 12 months operation; after 12 months the internal and external filters should be changed and the instrument should be gas tested in accordance with the instructions. Self-diagnostics will indicate the cause of any unusual malfunction. To obtain spare or replacement parts please contact Thermal Gas Systems, Inc.

Description	Part No.
Internal Filter, element	A702
External (EOL) Filter, element	A703
Switcher Valve	A501
Pressure Switch	A708
Scanner, 2-station	A501
Scanner, 4-station	A502
Scanner, 8-station	A503
Power Supply; 120/230VAC	A707
Pump	A709

**Figure 10 – Replacement Parts**

Description	Part No.
Audible Alarm, Local	A603
Strobe Alarm, Local	A607
Audible Alarm, Remote	A605
Strobe Alarm, Remote	A606
Combination Audible/Strobe Alarm,	A604
Gas Calibration Kit	A204

**Fig. 11- Accessories**

## SPECIFICATIONS

Technology: Narrow band Photoacoustic Infrared

Electrical Supply: 115-230 VAC, 50-60Hz; 65W

Fuse: 3A / 240V; Fast Acting

Output Signal: Std. 4x3A Dry Contact SPDT  
Opt. 7x10A. Dry Contact SPDT

Analog Output: Opt. 0 – 5VDC or 4 - 20mA  
Opt. RS232/485

Alarm Outputs: Three Level Contact Closure  
Opt. Seven Level Contact Closure

Readout: Digital LCD, Displays Channel, PPM  
Gas Type, and Fault Diagnostics

Display accuracy: 1ppm 10 - 100 ppm Range  
10ppm 100 - 1000 ppm Range

Ranges: 1 - 1000 ppm R-11, 12, 22, 123, 134a

Operating Conditions:

+40°F to +120°F Non-condensing

Fault Diagnostics: Indicator Light and LCD Readout  
(See Figure 5)

Enclosure: NEMA 12 Std., NEMA 4 optional

Weight: 15 lbs.

Dimensions: 12” W x 14” H x 4.5” D

Sensitivity 1ppm

Sample Rate 1.5Liter/min.

Response Time: < 1 Minute single point  
< 2.5 Minutes per point with optional scanner.

Channel	Gas Type	ALARM	PPM:
1		1	
2		2	
3		3	
4		4	
5		5	
6		6	
7			
8			

**Figure 12 - Initial Factory Settings**

GAS	TLV-TWA*	CEIL	PEL
R-11	•	1000	•
R-12	1000	•	1000
R-22	1000	•	1000
R-123	50	•	•
R-134a	1000	•	1000

**Figure 13- Refrigerant Exposure limits**

TLV-TWA = 8hr./day, 40hr./wk. avg. Short term exposures should not exceed 3 - 5 times the TWA for more than 30 min./day.

\* ACGIH Trademark.

• Other exposure limits are pending.

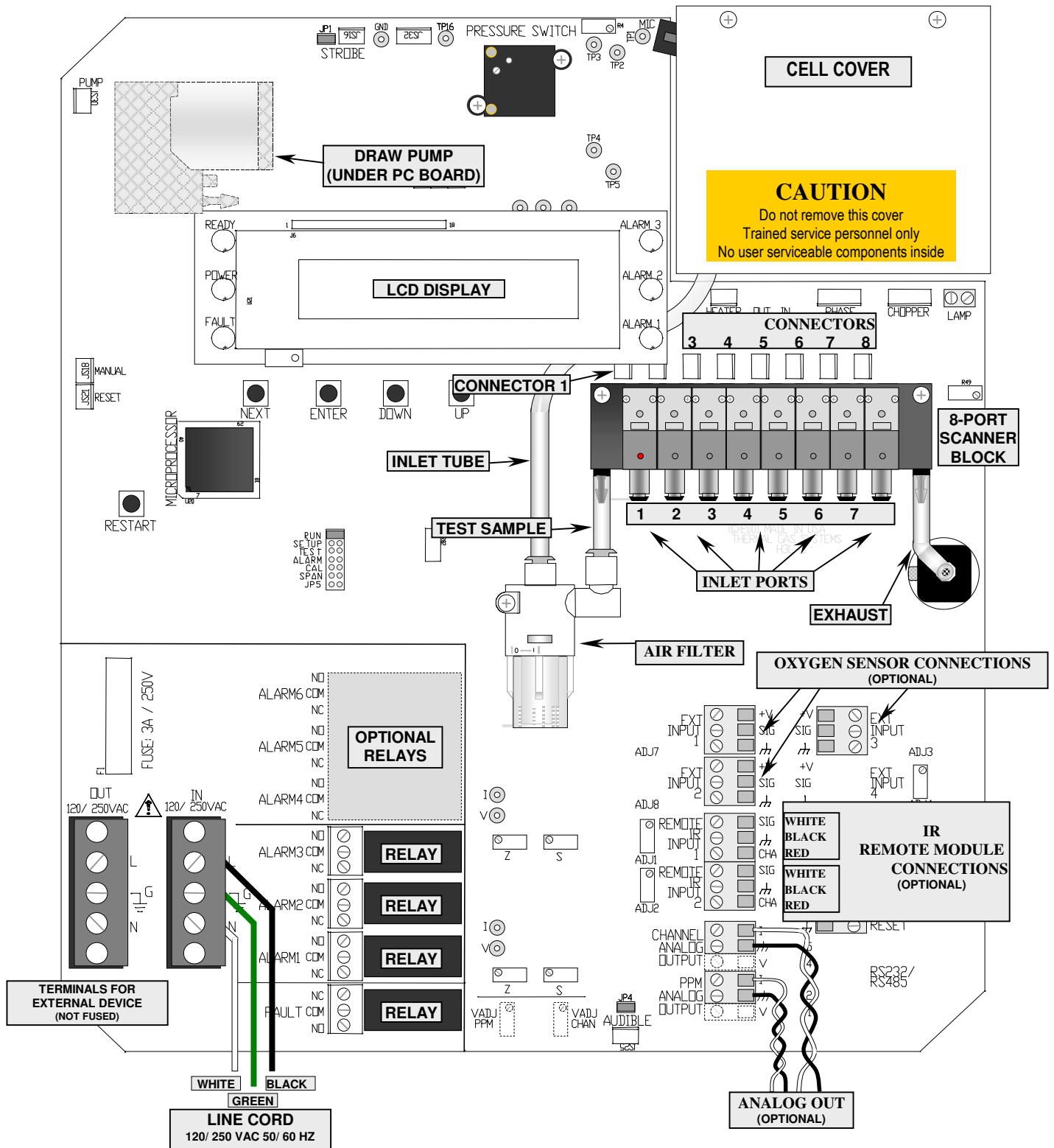

Figure 14 Wiring Diagram

## APPENDIX A

### ANALOG OUTPUT DATA TRANSLATION

#### PPM & FAULT DATA VALUES

To calculate the analog outputs of the display value (PPM) use the following formulas.

For Voltage out:  $V_{out} = ((PPM * 56) + 3277) * 7.629E-05$

For Current out:  $I_{out} = ((PPM * 56) + 3277) * 2.441E-04$

Display PPM values:

PPM	Vout (V)	Iout (mA)	Vterminated*
0	0.25	4.80	1.20
100	0.68	6.17	1.54
200	1.10	7.53	1.88
300	1.53	8.90	2.23
400	1.96	10.27	2.57
500	2.39	11.64	2.91
600	2.81	13.00	3.25
700	3.24	14.37	3.59
800	3.67	15.74	3.93
900	4.10	17.10	4.28
1000	4.52	18.47	4.62

Display Fault values:

Fault	Vout (V)	Iout (mA)	Vterminated*
Remote Discontinuity	0.000	4.00	1.00
Offscale	4.575	18.64	4.66
Pump Failure	4.675	18.96	4.74
Low Temperature	4.725	19.12	4.78
Lamp Failure	4.775	19.28	4.82
Chopper Failure	4.825	19.44	4.86
Scanner Stopped	4.875	19.60	4.90
Remote Channel Error	4.925	19.76	4.94
Remote In Setup	4.975	19.92	4.98

\* Voltage resulting from termination of Current out with a 250 Ohm resistor.

## ANALOG OUTPUT DATA TRANSLATION

### CHANNEL DATA VALUES

Channel	Voltage (V)	Current (mA)	Vterminated*
1	0.20	4.64	1.16
2	0.40	5.28	1.32
3	0.60	5.92	1.48
4	0.80	6.56	1.64
5	1.00	7.20	1.80
6	1.20	7.84	1.96
7	1.40	8.48	2.12
8	1.60	9.12	2.28
9	1.80	9.76	2.44
10	2.00	10.40	2.60
11	2.20	11.04	2.76
12	2.40	11.68	2.92
13	2.60	12.32	3.08
14	2.80	12.96	3.24
15	3.00	13.60	3.40
16	3.20	14.24	3.56
17	3.40	14.88	3.72
18	3.60	15.52	3.88
19	3.80	16.16	4.04
20	4.00	16.80	4.20
21	4.20	17.44	4.36
22	4.40	18.08	4.52
23	4.60	18.72	4.68
24	4.80	19.36	4.84

\* Voltage resulting from termination of Current out with a 250 Ohm resistor.