

QUICK START GUIDE

HEATED INLET FOR ENVIRONMENTAL ENCLOSURE



MODELS 8535 AND 8537

Thank you for purchasing a DustTrak™ Aerosol Monitor Heated Inlet Accessory. This guide will help you quickly begin using your Heated Inlet.

Unpacking

1. Carefully unpack the Heated inlet shipping container and verify that all the items listed in the following table are present.
2. Contact [TSI](#) immediately if items are missing or broken.
3. Additional items may be included if you ordered accessories or spare parts.

Qty.	Item Description	Reference Picture
1	Heated Inlet Column	
1	Temp/RH Probe	
1	Temp/RH Grommet	
1	Power Cable – Model 8535	
1	Power Cable – Model 8537	
1	90° Inlet	
1	Mounting Bracket Model 8535	
1	Mounting Bracket Model 8537	

Qty.	Item Description	Reference Picture
1	AutoZero Module*	
1	Cover – Sun Shield for Temp-Humidity Probe	

PN 801850 ships with AutoZero Module
 PN 801851 does not ship with AutoZero Module
 Heated inlet to be operated with the AutoZero Module

Preparation of Environmental Enclosure (8535) for Heated Inlet

1. The Environmental Enclosure may need a hole feature added, if purchased prior to ordering the Heated Inlet.

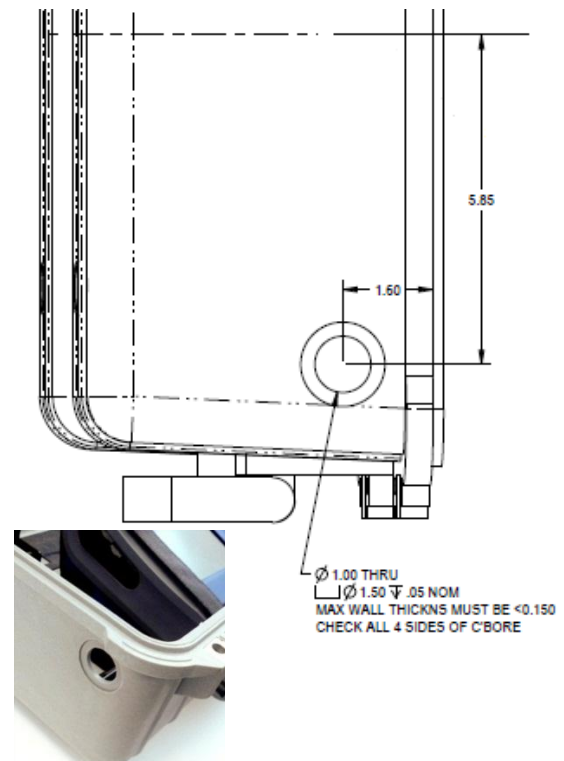

TSI and TSI logo are registered trademarks of TSI Incorporated.
 DustTrak is a trademark of TSI Incorporated. Velcro is a registered trademark of Velcro Industries B.V.



- The Environmental Enclosure Bracket may need two holes added. Check the back left section of the large black sheet metal bracket for the installed 6-32 PEM nuts.

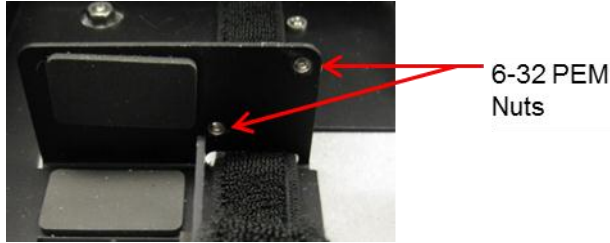

- If they are present, no modification is needed.
- If there are no 6-32 PEM nuts installed in the bracket, drill two $\text{\O} .189$ holes as indicated in the drawing below.

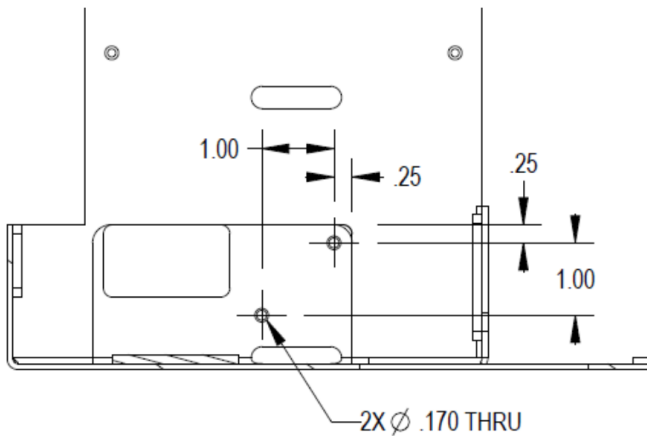

- Then use two 6-32 locking nuts on the back side of the flange when attaching the "Mounting Bracket."

Installing Heated Inlet- Model 8535

- Install the 90° Inlet next to the water trap.



- Mount the impactor (optional) and inlet tubing.



- Install the Heated Inlet on top of the Auto-Zero Module.

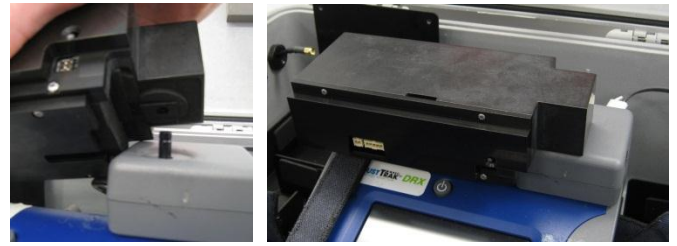

- If the Enclosure has the 6-32 PEM nuts, install the "Mounting Bracket" as shown—do **not** tighten.

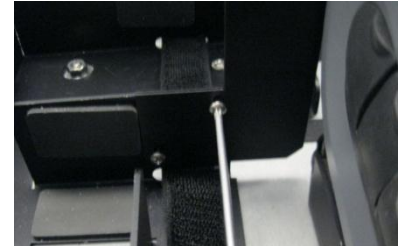

- If the Environmental Enclosure does **not** have the PEM nuts, install the "Mounting Bracket" using the 6-32 nuts—do **not** tighten.



- Attach the Mounting Bracket to the Heated Inlet with 8-32 thumbscrews—do **not** tighten.

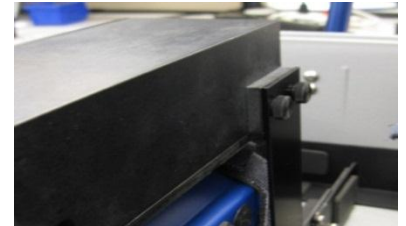

- Approximately level the Heated Inlet and tighten all screws.

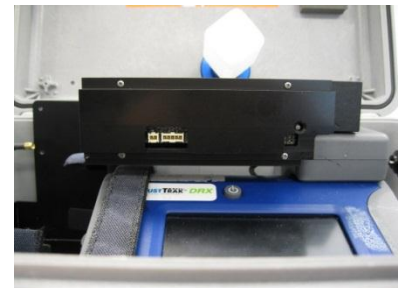

- Attach inlet tube to Heated Inlet.

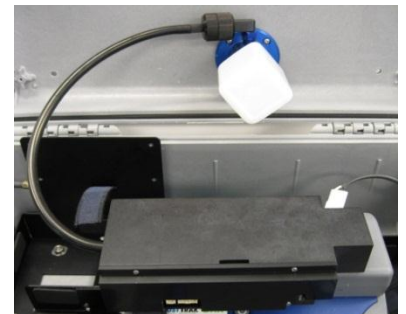

- Attach Temp/RH Grommet to Case.



- Push Temp/RH Probe through grommet and attach cable. Tighten grommet to secure probe with the sintered cover extending 1/4" (13mm) past the grommet.

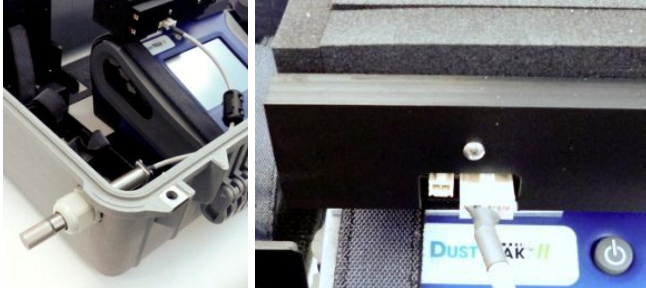

- Attach Power Cable for Model 8535 to incoming power, DustTrak monitor, and Heated Inlet.



Installing Heated Inlet- Model 8537

- Connect the Power Cable for Model 8537 to back panel.



- Insert the DustTrak monitor with Zero Module into its tray.

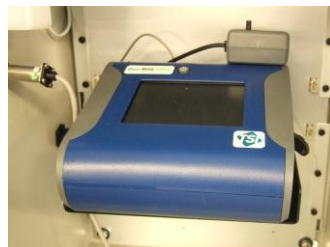

- Attach the Dusttrak monitor to the tray with the Velcro® strap.

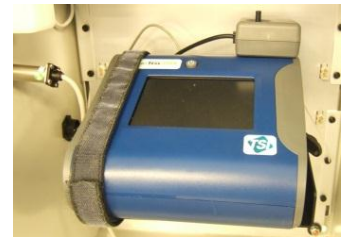

- Cut black inlet tubing to 7" length.



- Mount the impactor (optional), the inlet fitting and connect the tubing.



- Attach the bracket-8537 to the Heated Inlet Assy.



- Place the Heated Inlet on the Zero Module. Guide hole into tube of Zero Module.



- Align slots of bracket to holes in back panel and insert thumbscrews. .



- Check that Heated Inlet sits horizontal and tighten mounting thumbscrews.



10. Push Temp/RH Probe through grommet and attach cable. Tighten grommet to secure probe with the sintered cover extending 1/8" (3 mm) past the grommet.



11. In areas with intense sun it may be necessary to use the "Temp-Humidity-Screen" to obtain correct ambient temperature and humidity measurements. The screen easily clamps on the temperature humidity probe as shown. Make sure the "clamp" portion of the screen is in contact with the solid stainless steel part of the probe and is not touching the sintered part (see pictures of probe).



12. Attach the power cable to the Heated Inlet.



Operating Instructions

- When powered and attached to the DustTrak monitor, the Heated Inlet will automatically function.
- Select RH set point that will be controlled at the entrance to DustTrak monitor to be 30, 40 or 50% RH via the DIP switches. Heated inlet will then power heaters to heat incoming air and thereby decrease RH to the targeted level.

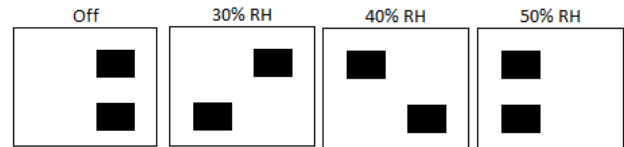

The LED describes the status of the heated inlet:

Solid Green	Inlet temp. is > 1°C below set point and controlling to maintain set point.
Blinking Green	Inlet temp. is between -1 to -5°C of set point and controlling to improve.
Blinking Red	Inlet temp. is more than 5°C below set point and controlling to improve. This will occur when unit is first turned on and coming to temperature.
Solid Red	Sensor unplugged or has issue.

Warning Labels

	Warns that the instrument could be hot to the touch or a burn hazard.
--	---

Specifications

Power	12 Volts DC; 13 Watts
Dimensions	7.6" x 3.5" x 2.3"
Weight	1 lb.
Temp Range	0 to 50°C
RH Range	0 to 95%
RH Set Points	30% RH, 40%RH, 50% RH
Warm-up Time	17 minutes
CE	IEC 61326 & IEC 61010-1



UNDERSTANDING, ACCELERATED

TSI Incorporated – Visit our website www.tsi.com for more information.

USA Tel: +1 800 874 2811
 UK Tel: +44 149 4 459200
 France Tel: +33 4 91 11 87 64
 Germany Tel: +49 241 523030

India Tel: +91 80 67877200
 China Tel: +86 10 8219 7688
 Singapore Tel: +65 6595 6388